

GILGAMESH

The movie

Seq	Scene	Panel
23	804	1

Action Notes
Continua

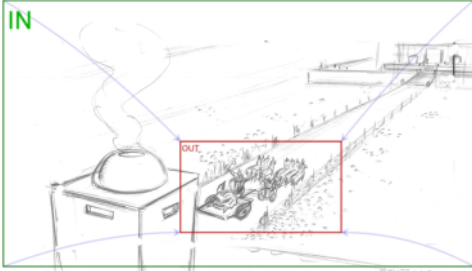

Seq	Scene	Panel
23	804	2

Action Notes
Fin mov cam

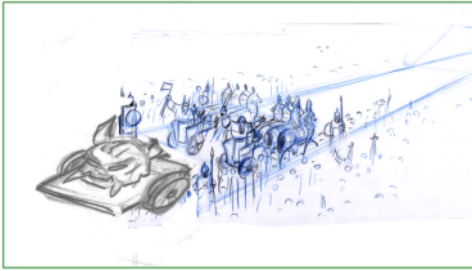

Seq	Scene	Panel
23	805	1

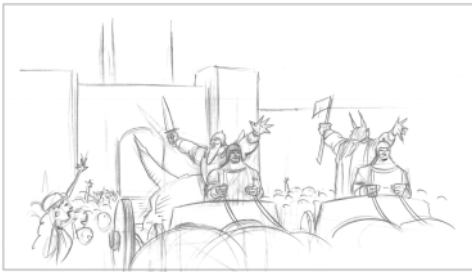

PAGE 8 1155271_ENTRER 1025 x 1026

Seq	Scene	Panel
23	806	1

Action Notes
Cam panea



Seq	Scene	Panel
23	806	2



Seq	Scene	Panel
23	806	3



Seq	Scene	Panel
23	807	1

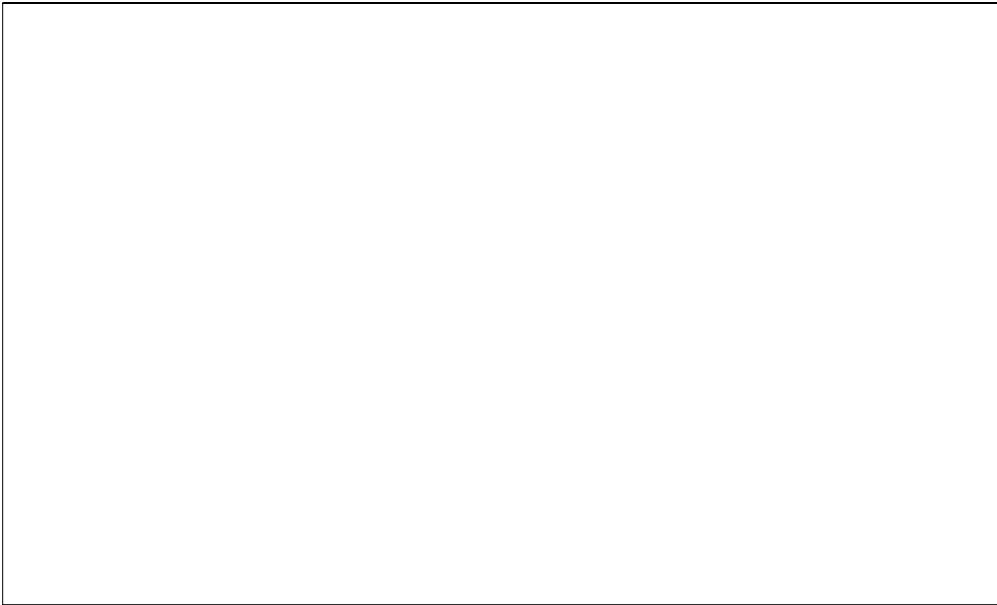

Seq	Scene	Panel
23	807	2

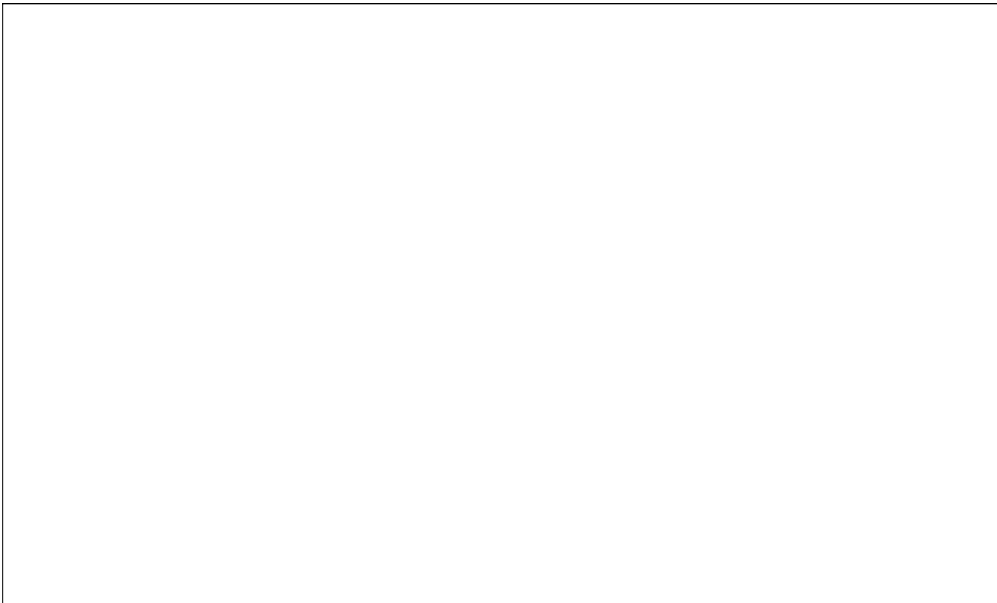

Seq	Scene	Panel
23	807	3

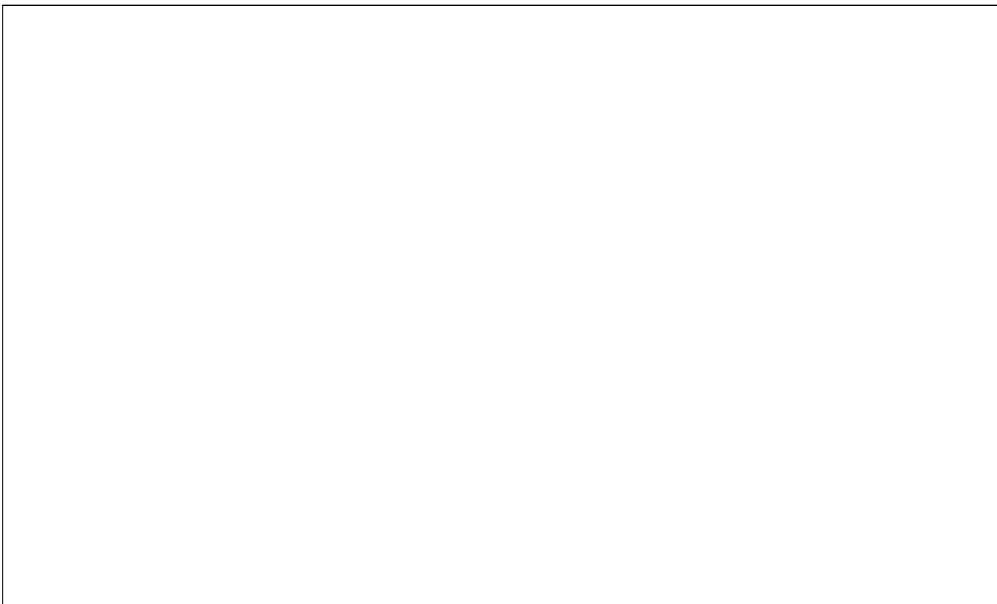

Seq	Scene	Panel
23	808	1



Dialog

NISNSÚN:
"HIJO MÍO!"

Seq	Scene	Panel
23	808	2

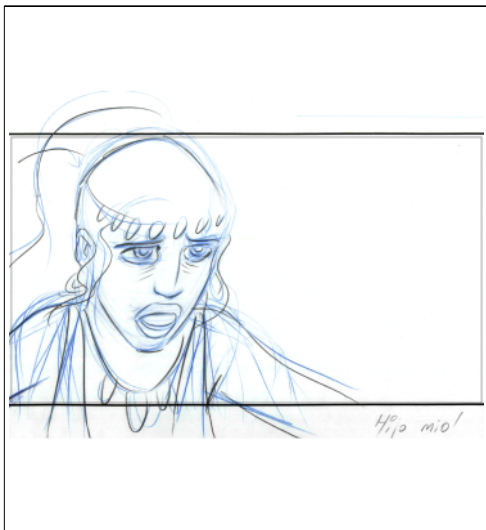

Dialog

Ninsún:
"BIENVENIDO!"

Seq	Scene	Panel
23	809	1



Dialog

Ninsún: Que alegría volver a verte!

Seq	Scene	Panel
23	810	1

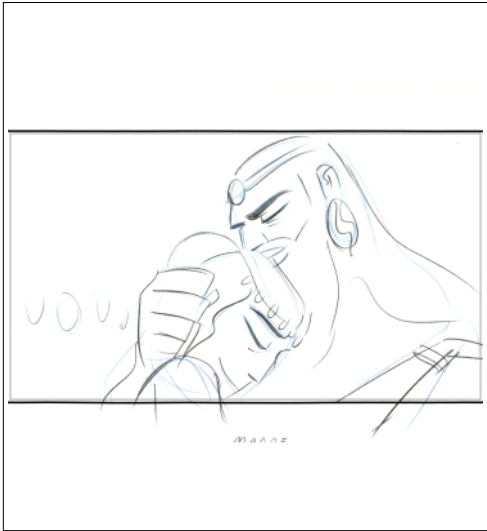

Dialog
Gilgamesh: Madre...

Seq	Scene	Panel
23	810	2



Dialog
Anciano del Consejo: Bienvenido y felicitaciones, mi rey!

Seq	Scene	Panel
23	811	1



Dialog
Anciano del Consejo: Venciste al temible Humbaba y así

Seq	Scene	Panel
23	812	1

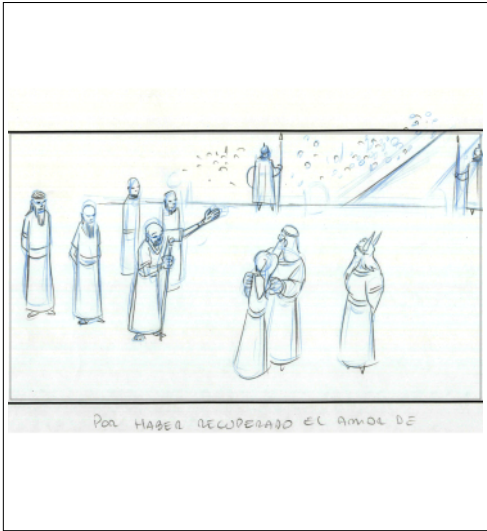

Dialog

Anciano del Consejo: recuperaste el amor de tu pueblo

Seq	Scene	Panel
23	813	1

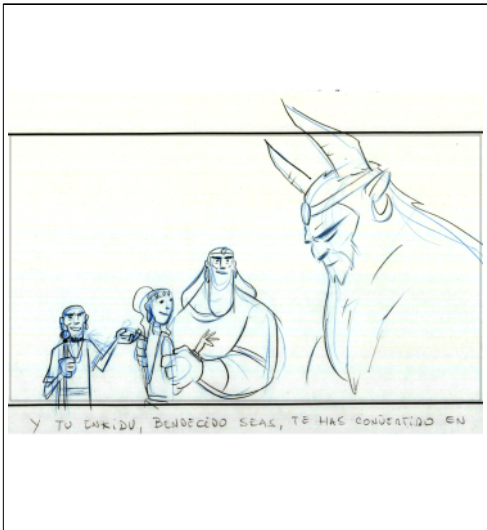

Dialog

Anciano del Consejo: Y a ti, Enkidu, gracias por comportarte como un verdadero hermano de nuestro rey.

Seq	Scene	Panel
23	813	2

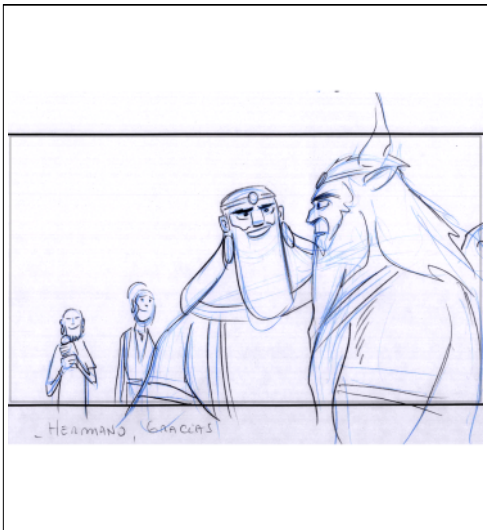

Dialog

Gilgamesh:
TU LO SABES,

Seq	Scene	Panel
23	813	3

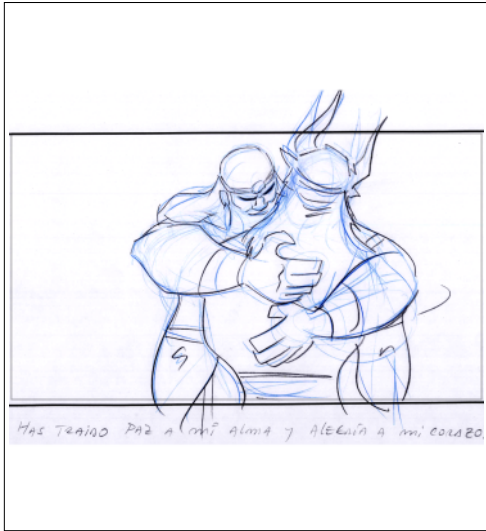

Dialog

Gilgamesh: Has traído alegría a mi corazón.

Seq	Scene	Panel
23	814	1

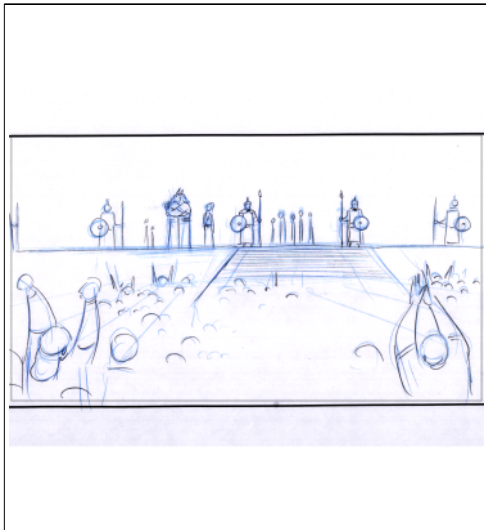

Action Notes

El pueblo vitorea y aplaude

Seq	Scene	Panel
24	815	1

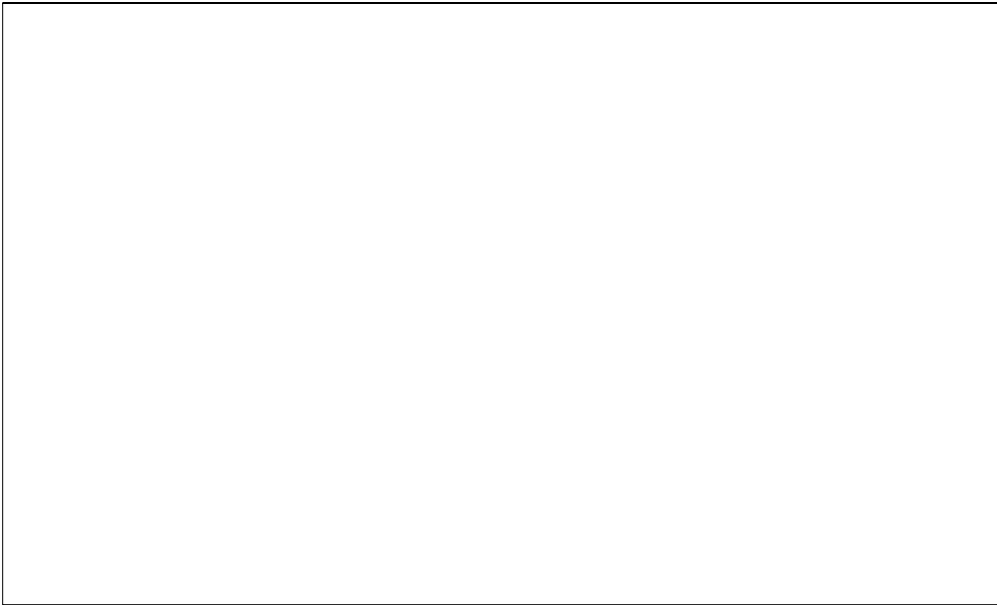
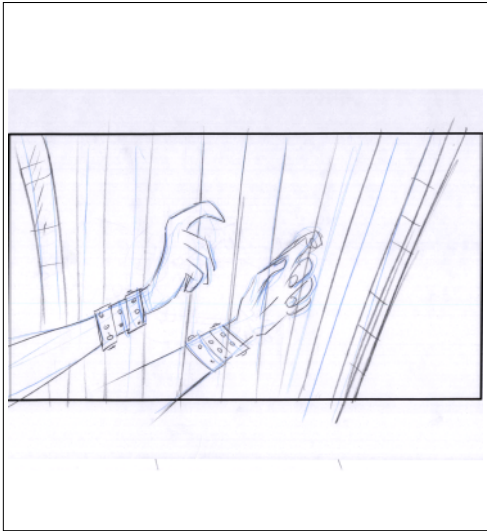

Seq	Scene	Panel
24	816	1

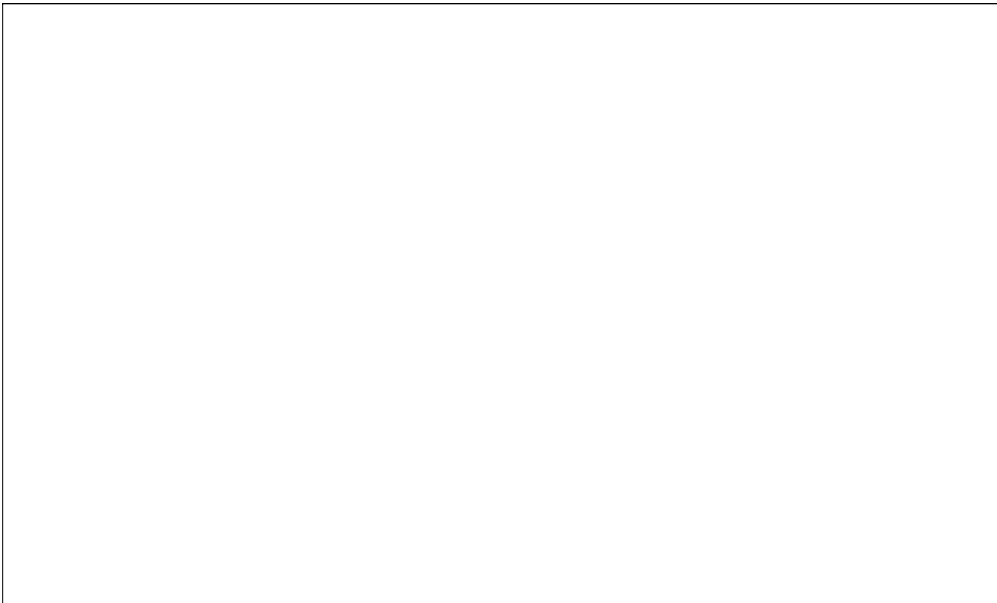
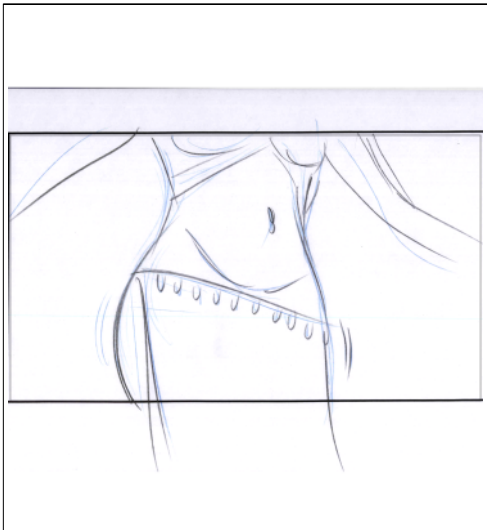

Seq	Scene	Panel
24	817	1

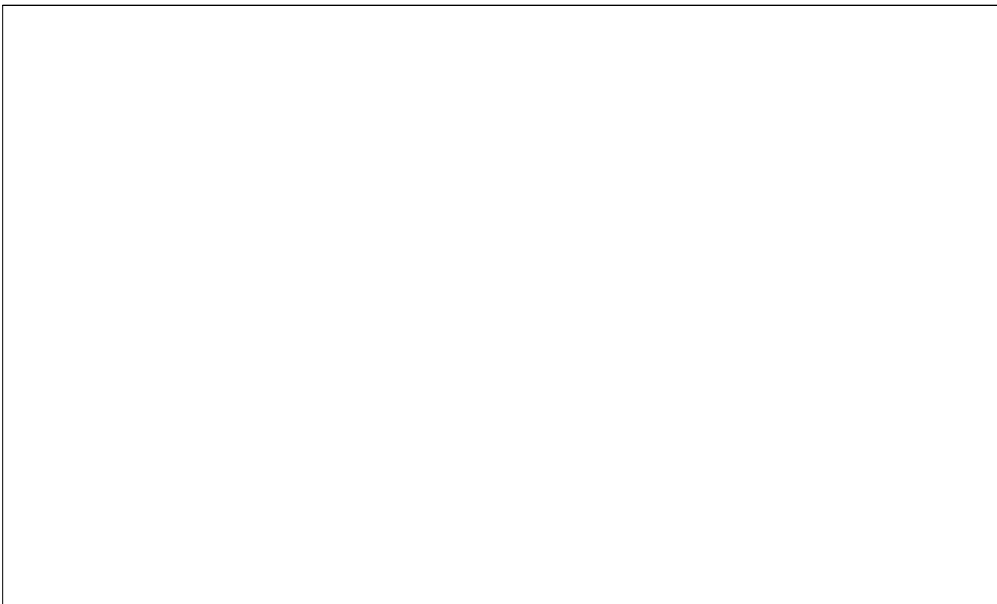
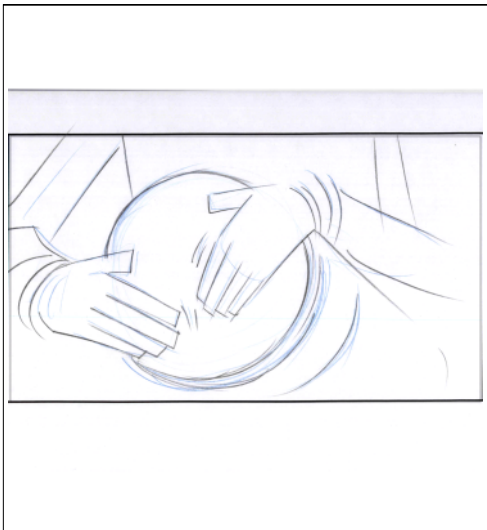

Seq	Scene	Panel
24	818	1

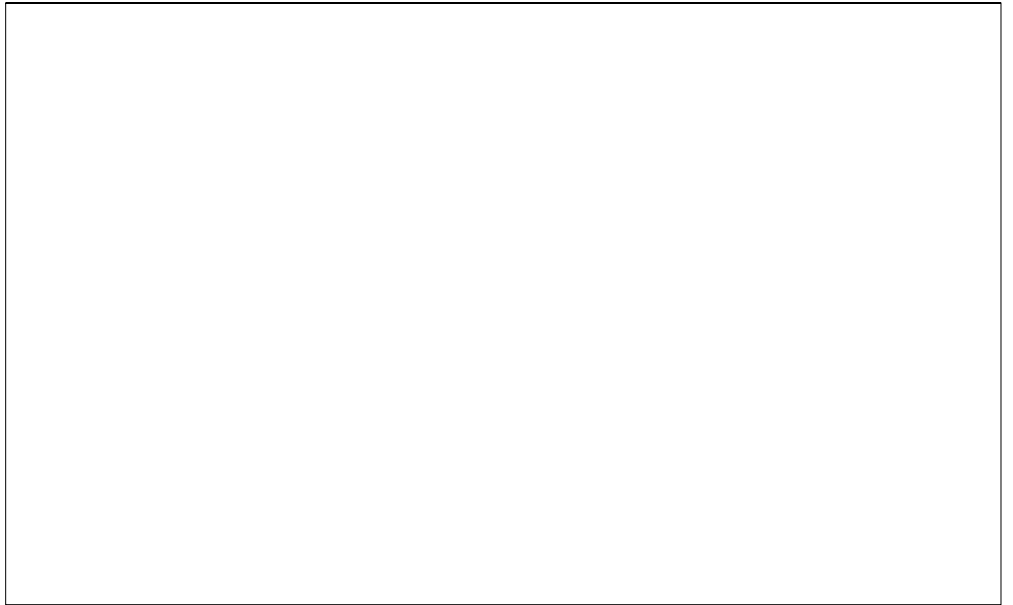
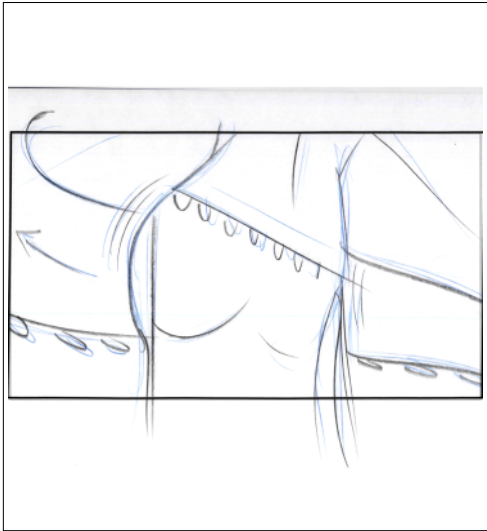

Seq	Scene	Panel
24	818	2

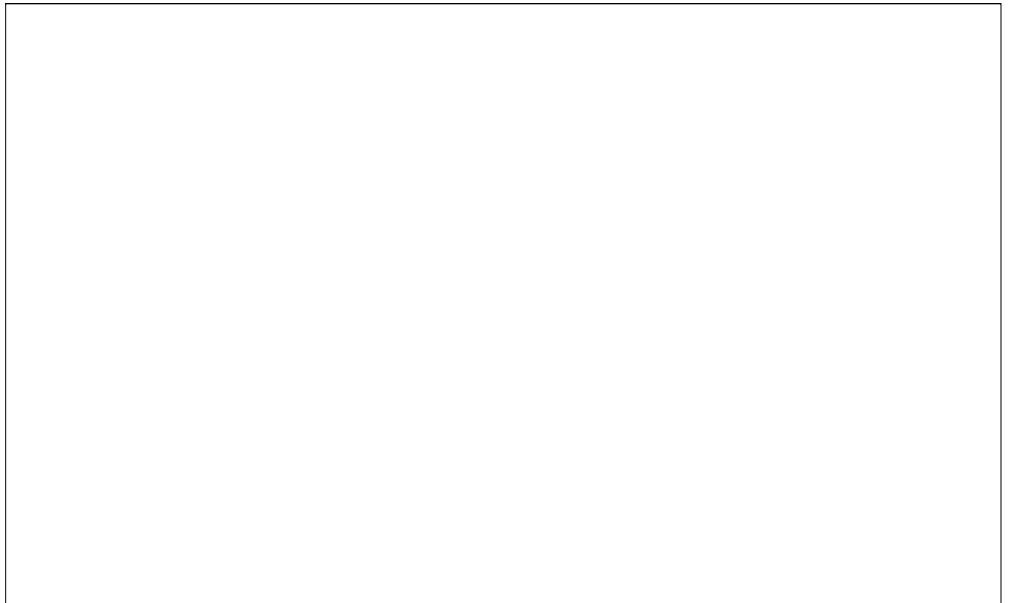
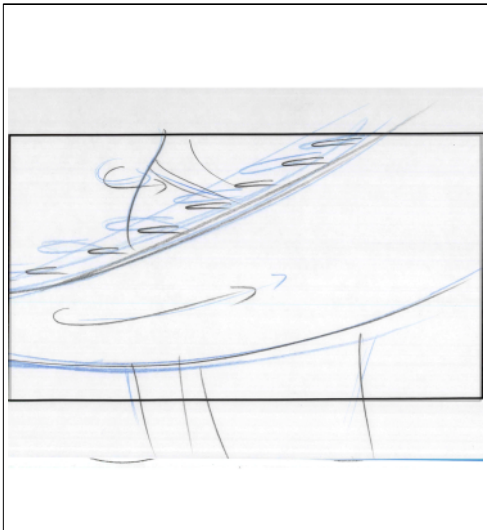

Seq	Scene	Panel
24	819	1

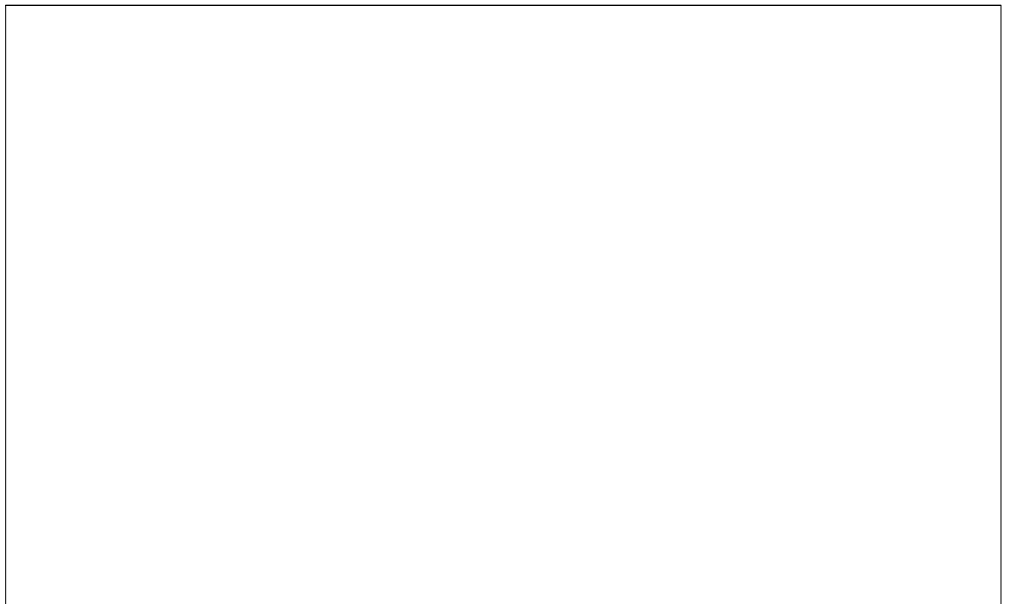
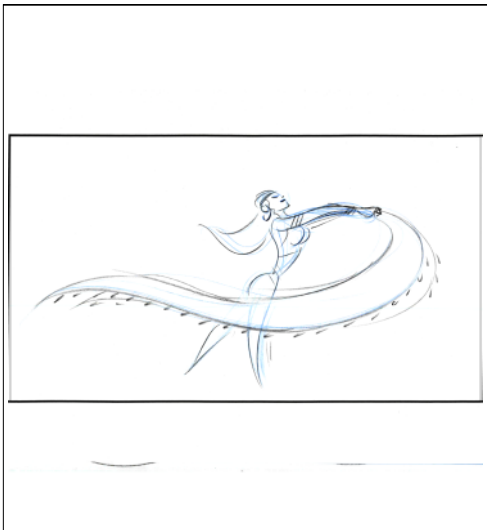

Seq	Scene	Panel
24	819	2

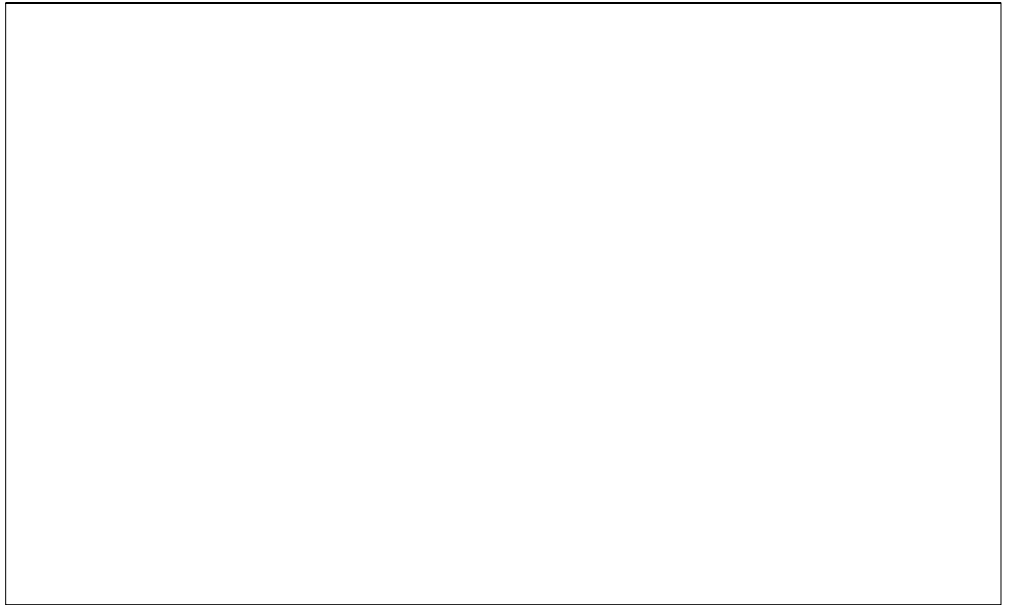
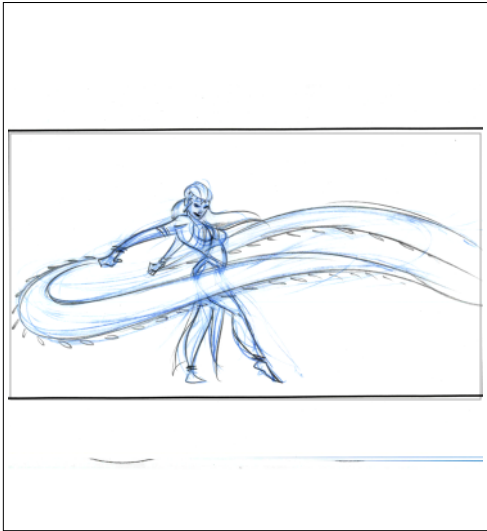

Seq	Scene	Panel
24	819	3

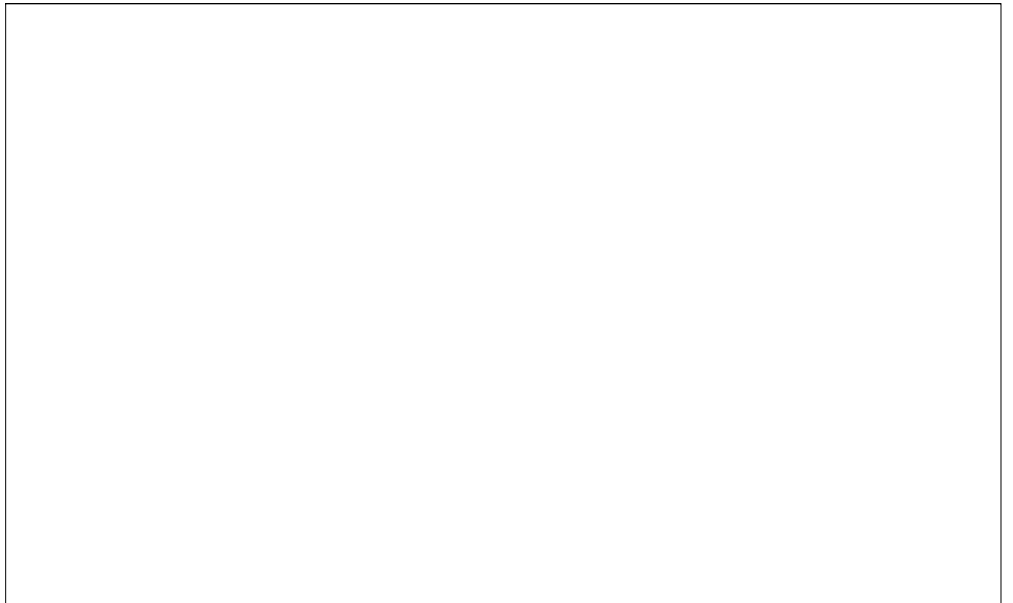
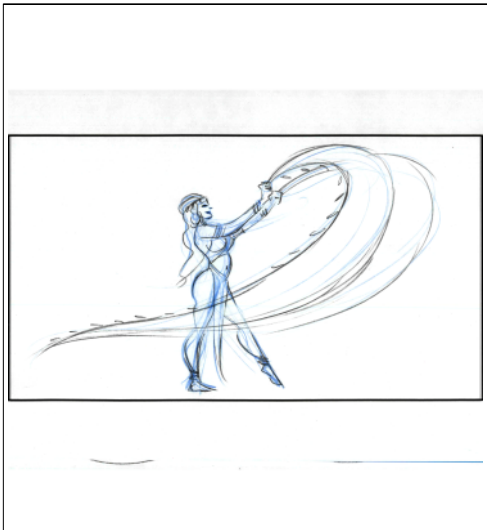

Seq	Scene	Panel
24	820	1

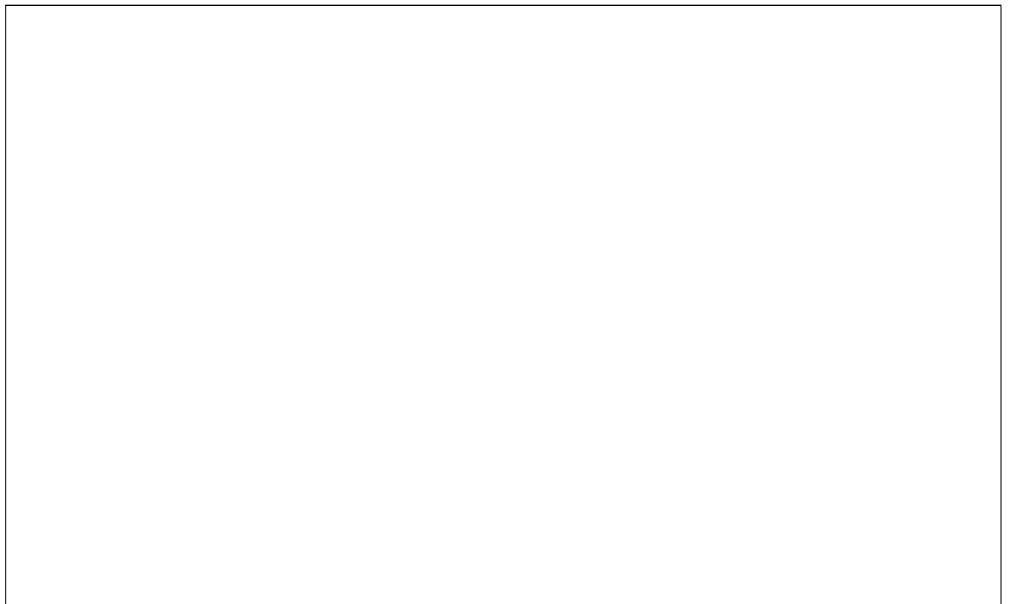
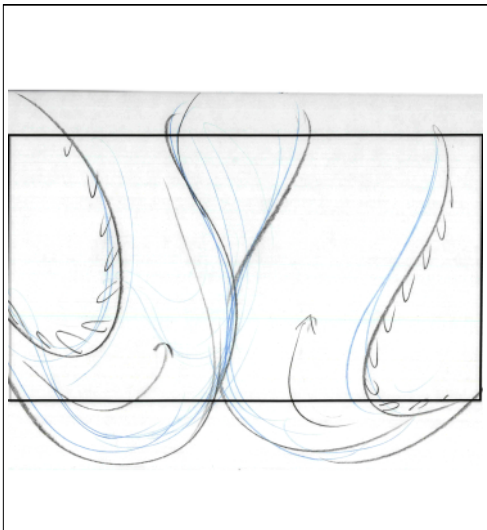

Seq	Scene	Panel
24	820	2

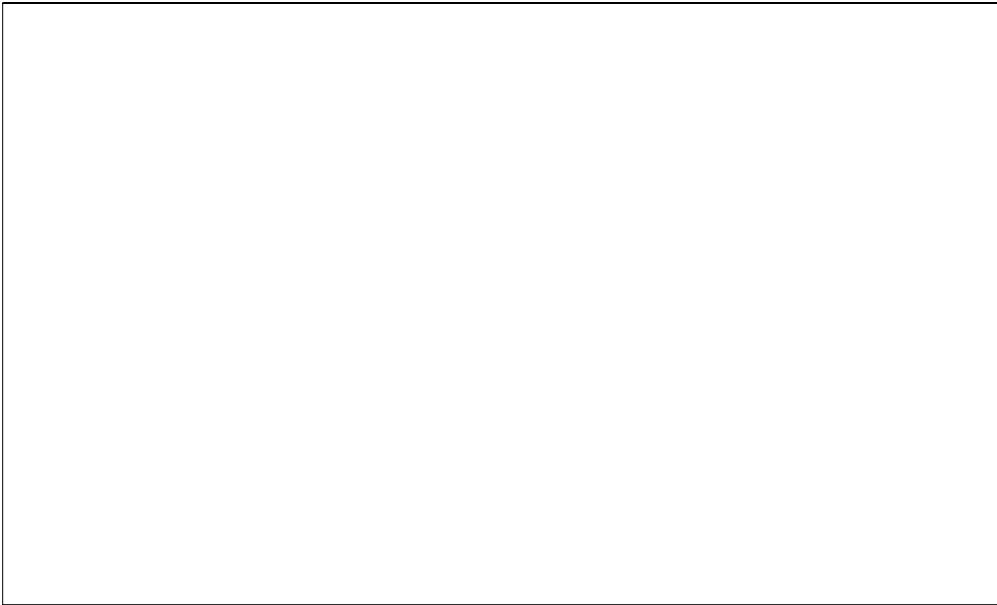
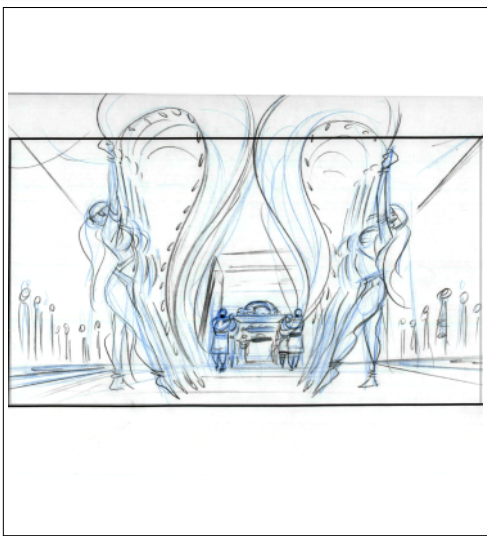

Seq	Scene	Panel
24	821	1



Dialog
 GILGAMESH (divertido, a las mujeres que lo miran)
 ¿Quién es el más hermoso y valiente entre los hombres?

Seq	Scene	Panel
24	821	2



Dialog
 (Contesta él mismo, rápidamente, y se ríe.)
 ¡Gilgamesh es el más hermoso

Seq	Scene	Panel
24	821	3



Dialog
y Enkidu, el más valiente!

Seq	Scene	Panel
24	822	1



Dialog
GILGAMESH EN OFF. JAJAJAAAJAA

Seq	Scene	Panel
24	823	1

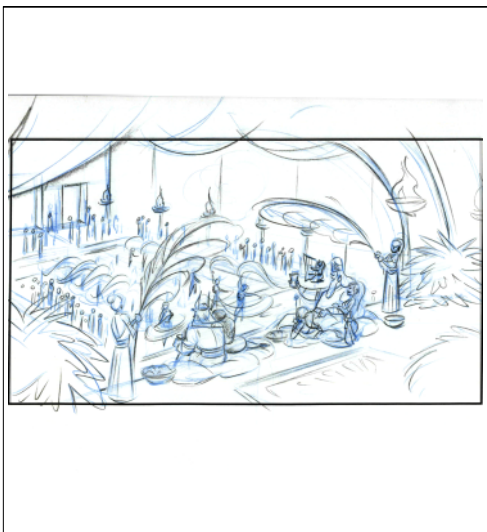

Seq	Scene	Panel
25	824	1

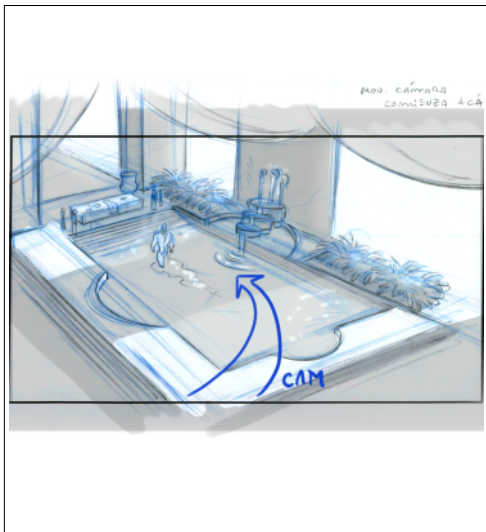

Action Notes

Vemos un interior del palacio. Una piscina interna donde Gilgamesh toma un baño tras limpiar sus armas

Seq	Scene	Panel
25	824	2

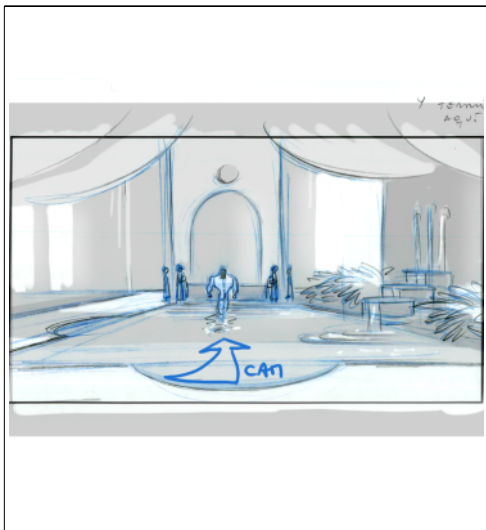

Action Notes

La camara gira y se coloca detras de Gilgamesh quien se dirige hacia las escaleras al final de la piscina, donde lo esperan sus esclavas

Seq	Scene	Panel
25	825	1



Action Notes

Una vez fuera, las esclavas secan a Gilgamesh

Seq	Scene	Panel
25	826	1

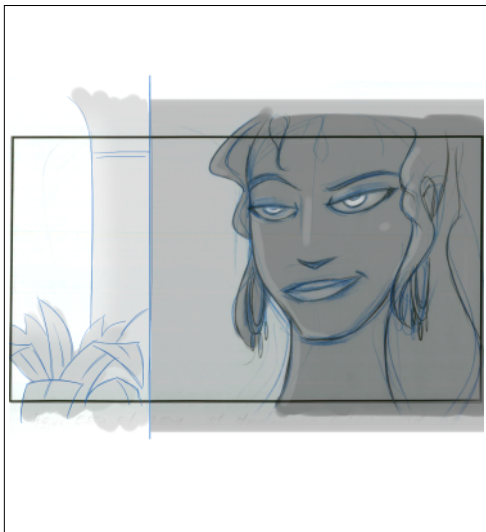

Dialog

ISHTAR(para sí misma)
Aquí está el rey, el hermoso Gilgamesh, de belleza sin igual.

Action Notes

Primer plano de Ishtar, que mira a Gilgamesh con lujuria

Seq	Scene	Panel
25	827	1

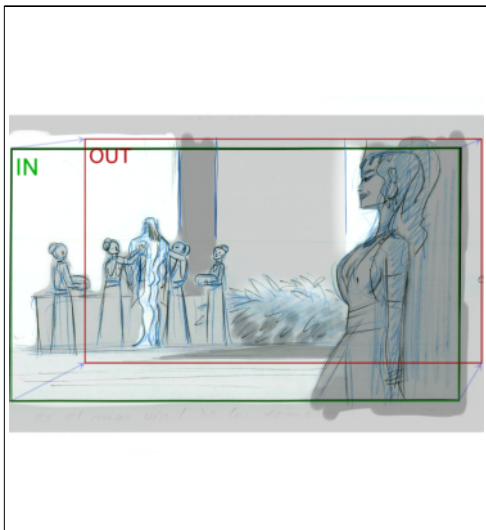

Dialog

ISHTAR(para sí misma)
Es el más viril de los hombres y su cuerpo enciende mi deseo.

Action Notes

Ishtar observa la escena apoyada en una columna, a unos metros de distancia

Seq	Scene	Panel
25	828	1

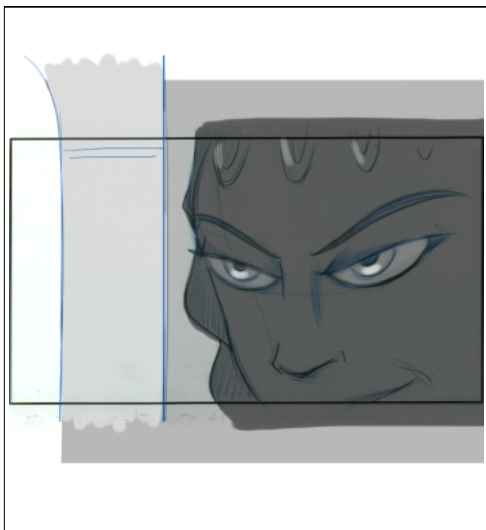

Dialog

ISHTAR(para sí misma)
Su triunfo frente al monstruo Jumbaba lo ha hecho aun más deseable. Será mío. Será uno más de mis trofeos.

Action Notes

Plano detalle de Ishtar

Seq	Scene	Panel
25	829	1



Dialog

ISHTAR (a GILGAMESH, ansiosa)
Valiente Gilgamesh,

Action Notes

La esclavas visten a Gilgamesh

Seq	Scene	Panel
25	829	2



Dialog

ISHTAR (a GILGAMESH, ansiosa)
sé mi amante, hazme el regalo de tu amor.

Action Notes

Ishtar avanza y se dirige a Gilgamesh

Seq	Scene	Panel
25	830	1



Dialog

ISHTAR (a GILGAMESH, ansiosa)
¡Ofréceme tu virilidad!

Action Notes

Primer plano de Ishtar

Seq	Scene	Panel
25	831	1

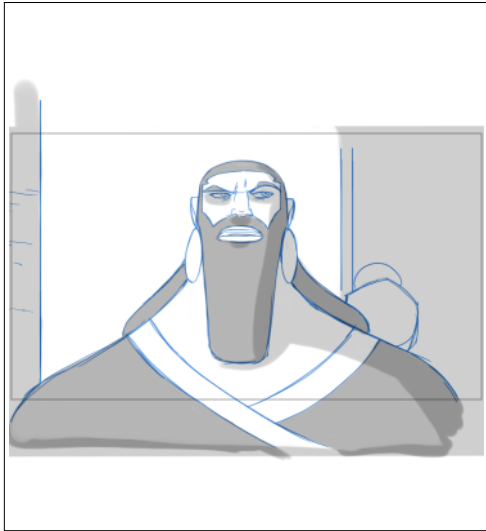

Dialog

ISHTAR EN OFF:
Sé mi esposo.

GILGAMESH:
¿QUÉ DICES ISHTAR?

Seq	Scene	Panel
25	832	1

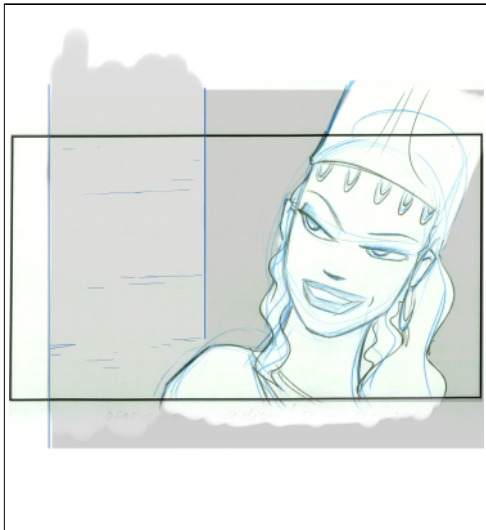

Dialog

ISHTAR
"Si lo haces, ordenaré construir para ti

Action Notes

Primer plano de Ishtar

Seq	Scene	Panel
25	833	1



Dialog

ISHTAR (a GILGAMESH, ansiosa)
un carro de guerra de oro y lapislázuli. Su timón será de ámbar

Action Notes

Ishtar se acerca aun mas a Gilgamesh, quien la escucha imasible.

Seq	Scene	Panel
25	834	1



Dialog

ISHTAR (a GILGAMESH, ansiosa)
y sus ruedas, de mármol. Cada mañana, después de dejar mi cama,

Action Notes

Subjetiva de Ishtar. La camara debe girar

Seq	Scene	Panel
25	834	2

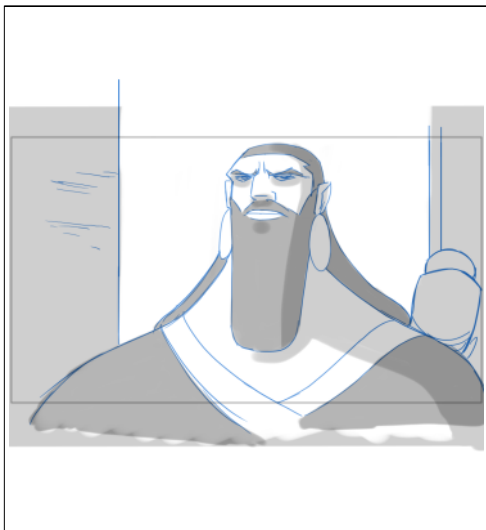

Dialog

ISHTAR (a GILGAMESH, ansiosa)
y sus ruedas, de mármol. Cada mañana, después de dejar mi cama,

Action Notes

Subjetiva de Ishtar. La camara debe girar

Seq	Scene	Panel
25	834	3

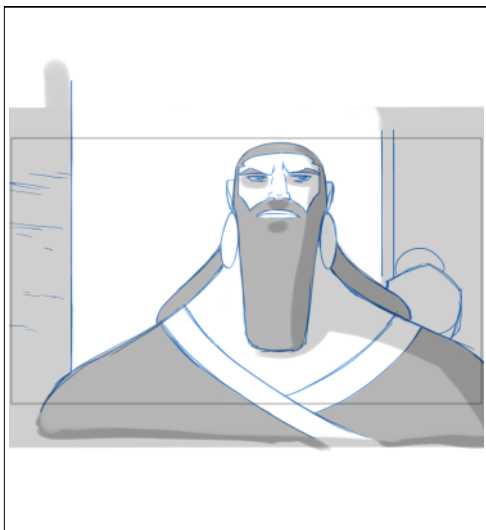

Dialog

ISHTAR (a GILGAMESH, ansiosa)
y sus ruedas, de mármol. Cada mañana, después de dejar mi cama,

Action Notes

Subjetiva de Ishtar. La camara debe girar

Seq	Scene	Panel
25	835	1

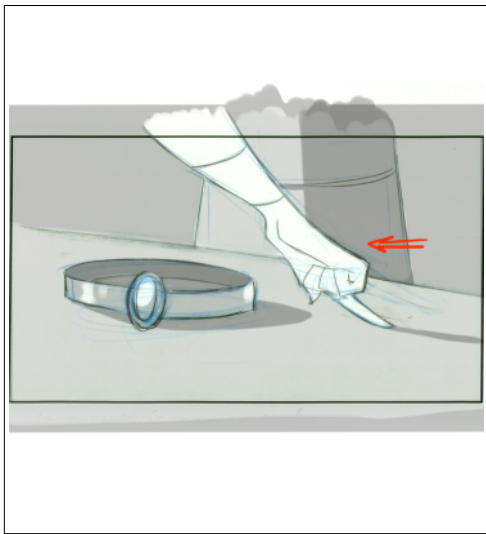

Dialog

ISHTAR (a GILGAMESH, ansiosa)
le engancharás magníficos caballos,

Action Notes

El dedo de Ishtar roza la mesa donde reposa la corona de Gilgamesh

Seq	Scene	Panel
25	835	2

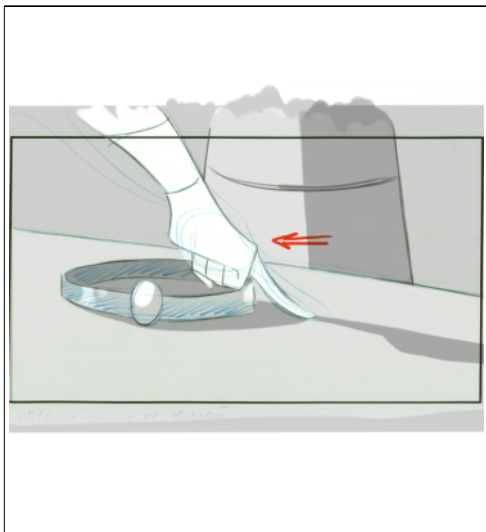

Dialog

ISHTAR (a GILGAMESH, ansiosa)
veloces como el huracán.

Action Notes

y se acerca a esta

Seq	Scene	Panel
25	835	3

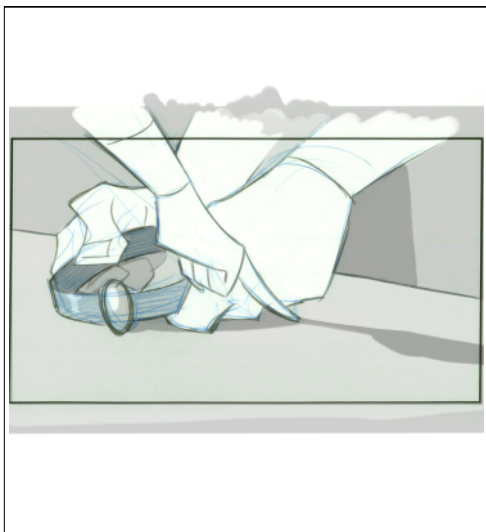

Action Notes

Gilgamesh toma su corona de la mesa

Seq	Scene	Panel
25	836	1

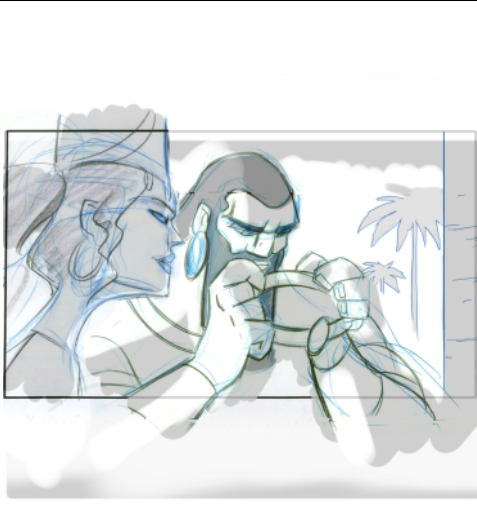

Dialog

ISHTAR
También

Action Notes

Gilgamesh continua sin inmutarse

Seq	Scene	Panel
25	836	2

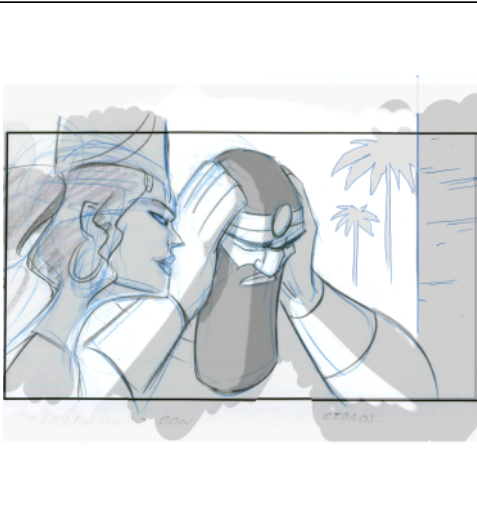

Dialog

ISHTAR
te daré un palacio,

Action Notes

Se coloca la corona. Ishtar entra a escena

Seq	Scene	Panel
25	836	3



Dialog

ISHTAR
perfumado con esencia de cedros.

Action Notes

Ishtar se acerca a Gilgamesh

Seq	Scene	Panel
25	836	4

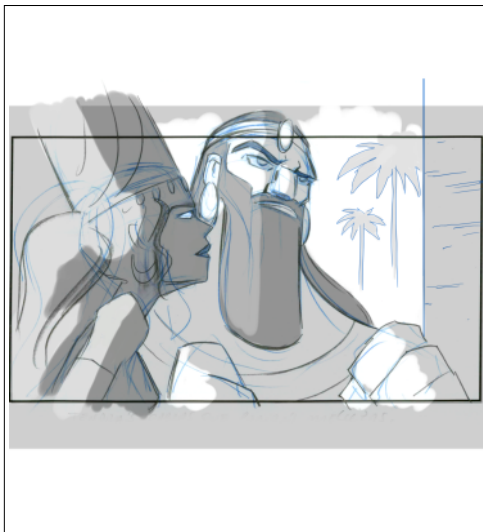

Dialog

ISHTAR
Y haré, que reyes, príncipes y nobles

Action Notes

Ishtar se acerca cada vez mas, procurando persuadir a Gilgamesh con sus encantos

Seq	Scene	Panel
25	836	5

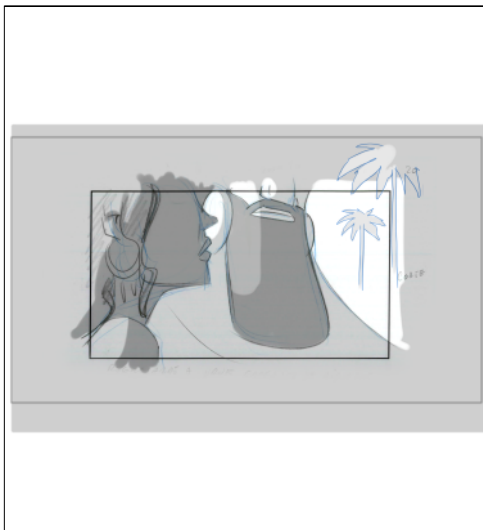

Dialog

ISHTAR
besen tus pies.

Action Notes

Zoom in

Seq	Scene	Panel
25	837	1



Dialog

GILGAMESH (con aire sobrador, irónico)
¿Y qué tendré que darte yo, si soy tu amante? ¿Vestidos y perfumes? ¿Y también alimentos dignos de una divinidad? ¿Qué cosa, que ya no tengas?

Action Notes

Gilgamesh se da vuelta y por primera vez mira a Ishtar. Toma su mano y le habla

Seq	Scene	Panel
25	837	2

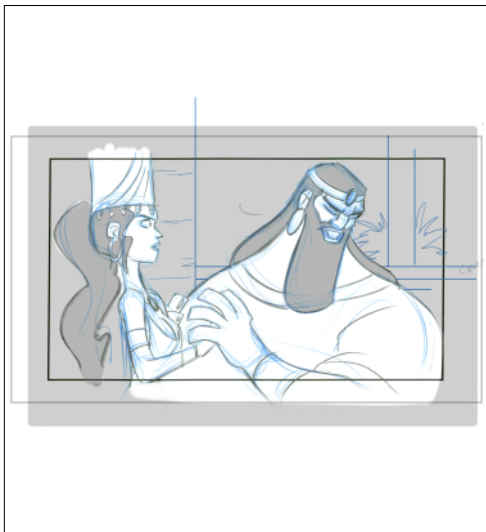

Dialog

(sigue GILGAMESH, con decisión y malicia)
 No, hermosa Ishtar, protectora de Uruk, señora del amor.

Action Notes

Gilgamesh suelta la mano de Ishtar y la rechaza.

Seq	Scene	Panel
25	838	1



Dialog

sigue GILGAMESH, con decisión y malicia)
 ¡No te tomaré como esposa!

Seq	Scene	Panel
25	839	1

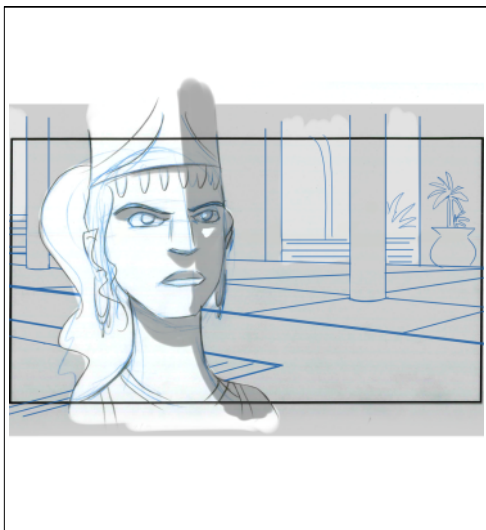

Dialog

GILGAMESH EN OFF
 ¡No seré tu hombre!
 ¡Porque eres asfalto que ensucia a quien lo toca!

Action Notes

Ishtar lo mira, perpleja.

Seq	Scene	Panel
25	840	1



Dialog

(sigue GILGAMESH, con decisión y malicia)
 ¡Una sandalia que estropea el pie de quién la calza! ¡Una puerta que no detiene ni la brisa ni el huracán!

Action Notes

Primer plano de Gilgamesh

Seq	Scene	Panel
25	841	1

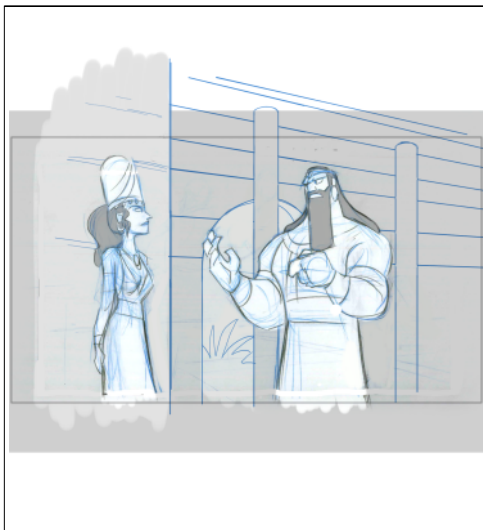

Dialog

GILGAMESH
 No amaste para siempre a ninguno de tus elegidos. ¡Escucha! Esta es la lista de tus conquistas.

Action Notes

Gilgamesh habla con malicia a Ishtar sobre sus amores del pasado, mientras ella lo mira, cada vez mas molesta

Seq	Scene	Panel
25	841	2

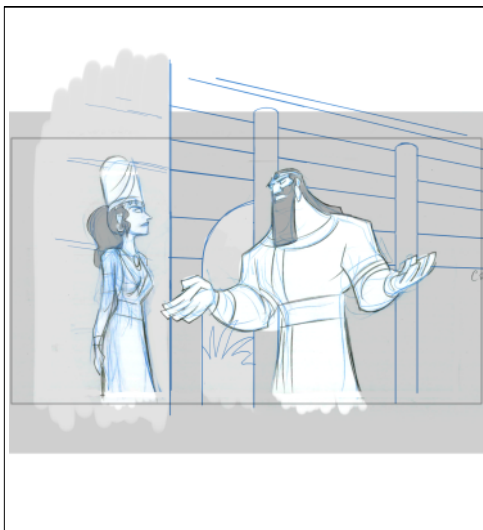

Dialog

GILGAMESH
 Recuerda a Dumuzi, el amor de tu juventud.

Action Notes

Gilgamesh habla con malicia a Ishtar sobre sus amores del pasado, mientras ella lo mira, cada vez mas molesta

Seq	Scene	Panel
25	842	1

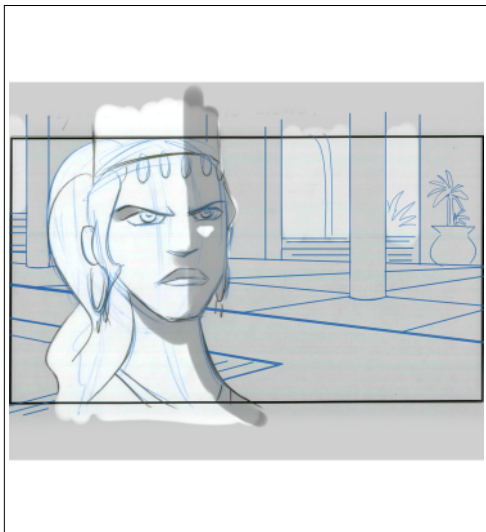

Dialog

GILGAMESH

Cuando te cansaste de sus atenciones, solo le dejaste un llanto eterno.

Action Notes

Ishtar comienza a enfurecer

Seq	Scene	Panel
25	843	1



Dialog

GILGAMESH

Y no olvides a Gálgulo, el pájaro multicolor. Al final lo golpeaste y le rompiste las alas.

Seq	Scene	Panel
25	844	1

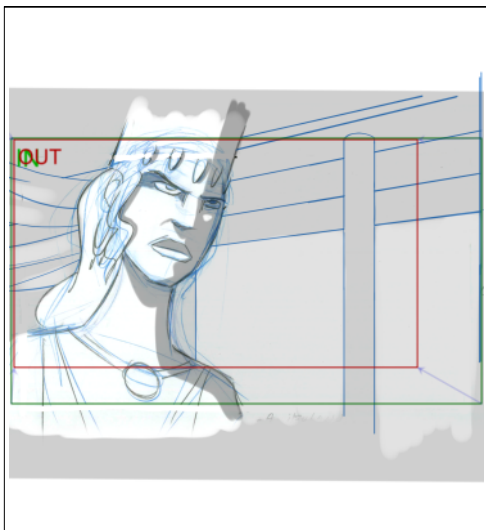

Dialog

GILGAMESH (en off)

Y recuerda al guardián de tus rebaños, que siempre te ofrecía sus mejores carneros.

Action Notes

Ishtar va poniendose cada vez mas furiosa

Seq	Scene	Panel
25	845	1

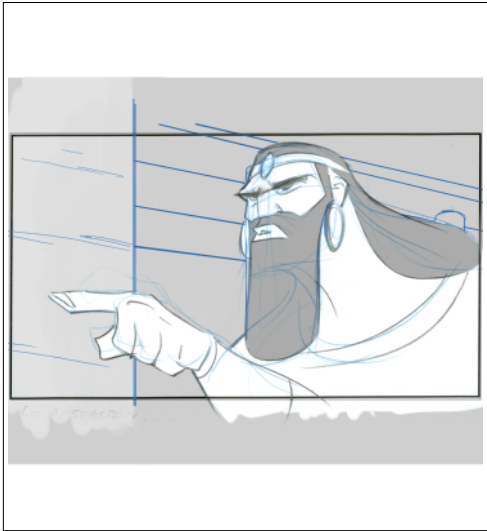

Dialog

GILGAMESH
Tú lo transformaste en lobo

Seq	Scene	Panel
25	846	1



Dialog

GILGAMESH
y ahora sus propios perros le muerden los muslos.

Seq	Scene	Panel
25	847	1

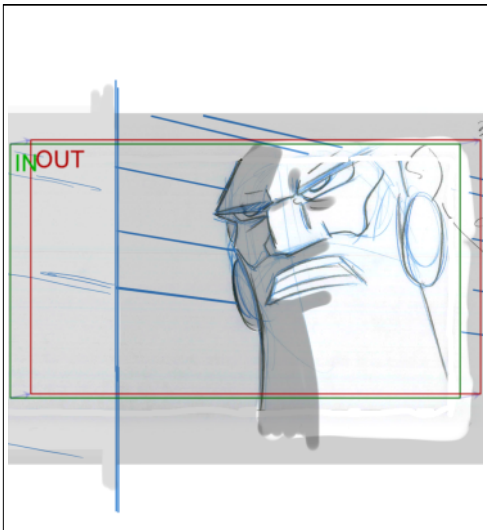

Dialog

GILGAMESH
Si fuera tu amante, ¿harías lo mismo conmigo!

Action Notes

Gilgamesh la mira, desafiante

Seq	Scene	Panel
25	848	1

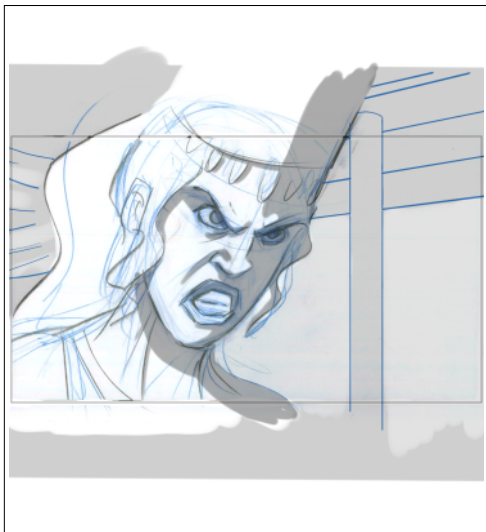

Dialog

ISHTAR
¡Tu desaire te costará caro, lo juro, Gilgamesh!

Action Notes

Ishtar esta totalmente furiosa y maldice a Gilgamesh

Seq	Scene	Panel
25	849	1

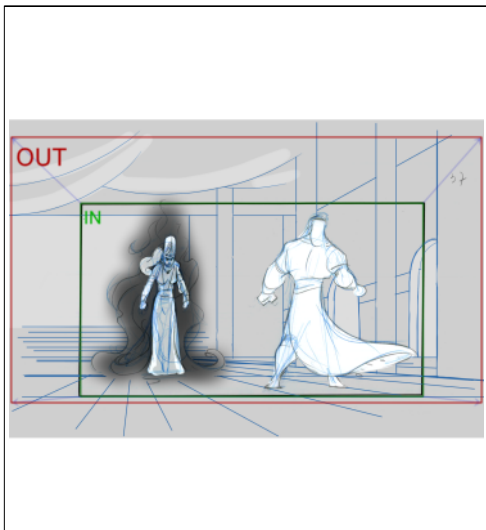

Dialog

ISHTAR
Los dioses te enviarán el peor de los castigos, para que pagues esta

Action Notes

Un vapor maligno rodea su cuerpo

Seq	Scene	Panel
25	849	2

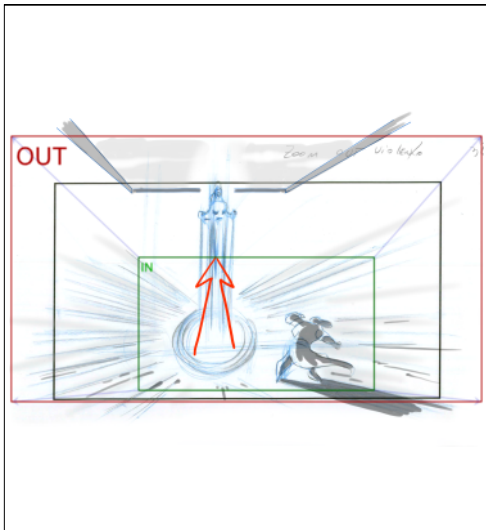

Dialog

ISHTAR
ofensaaa!

Action Notes

Y se eleva hacia el cielo, gritando
Zoom out violento

Seq	Scene	Panel
26	850	1

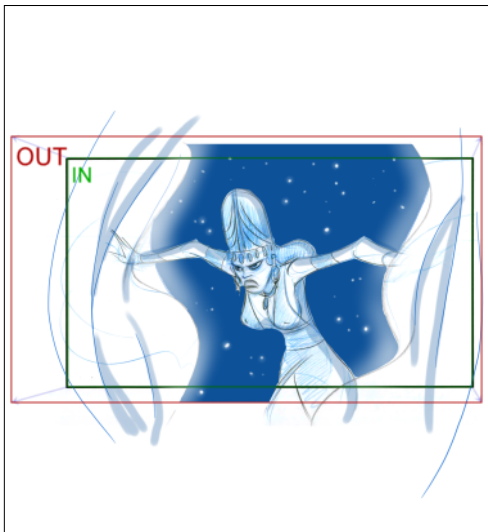

Dialog

ISHTAR
Anú!

Action Notes

Ishtar irrumpe furiosa en los aposentos del dios Anu

Seq	Scene	Panel
26	850	2

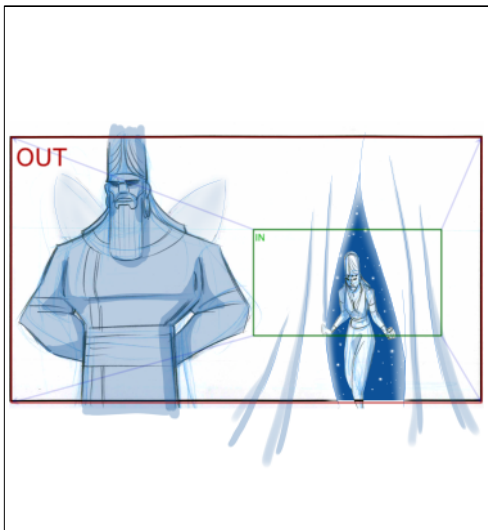

Dialog

ISHTAR
padre mío, Gilgamesh me insultó. ¡Dijo infamias sobre mí!

Action Notes

Zoom Out - Vemos al dios parado de espaldas a Ishtar

Seq	Scene	Panel
26	850	3



Dialog

ANÚ
¿Qué, no fuiste tú quién lo provocó? ¿Acaso no requeriste su amor y él, en respuesta, enumeró tus ofensas y abominaciones?

Seq	Scene	Panel
26	851	1



Dialog

ISHTAR

Gilgamesh no tiene derecho ni poder para enfrentarme. Él, como todos, debe complacer mi deseo. Pero se negó y por eso debe ser castigado.

Action Notes

Primer plano de Ishtar, molesta

Seq	Scene	Panel
26	852	1



Dialog

ISHTAR

Padre, envía al Toro del Cielo, para que mate a Gilgamesh e incendie Uruk.

Action Notes

Ishtar exige a su padre que libere al Toro de los Cielos

Seq	Scene	Panel
26	853	1



Dialog

ISHTAR

Si no lo haces, bajaré a los Infiernos, romperé sus puertas y haré que los muertos vuelvan a la Tierra para abatir a los vivos!

Action Notes

Lo amenaza con revivir a los muertos

Seq	Scene	Panel
26	854	1

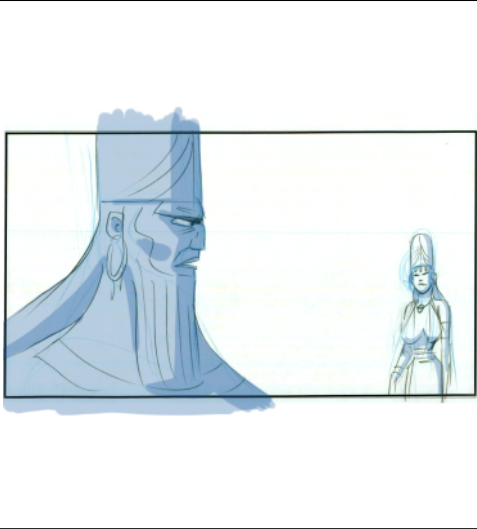

Dialog

ANÚ (tratando de convencerla)

Si el Toro del Cielo baja con su fuego devastador, Uruk sufrirá siete años de sequía. ¿Qué será de tu pueblo, si su protectora le envía tamaña calamidad?

Action Notes

Anu se voltea para hablar con su hija

Seq	Scene	Panel
26	855	1

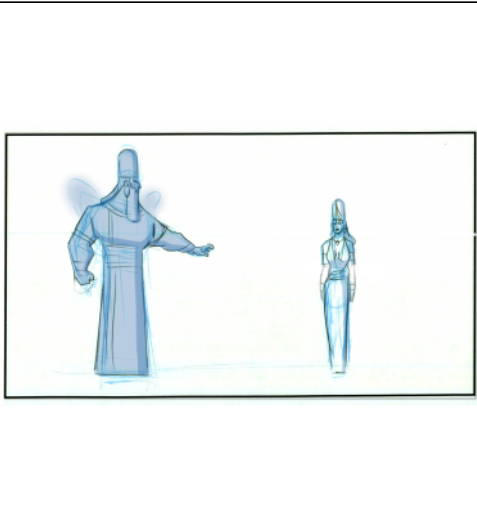

Dialog

ANÚ

Puedo otorgarte lo que pides pero, a cambio, antes deberás almacenar alimentos para que la gente sobreviva durante ese tiempo.

Action Notes

Trata de persuadirla de su pedido

Seq	Scene	Panel
26	856	1



Dialog

ISHTAR

Sí, padre, ya tomé esa precaución. Para la población, tengo comida reservada. Y hierba suficiente para que coman los animales durante siete años.

Action Notes

Detalle de Ishtar

Seq	Scene	Panel
26	857	1

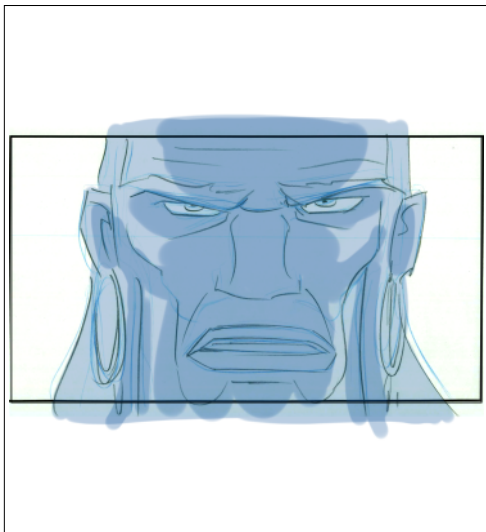

Dialog

ANÚ

Entonces, haré bajar al Toro de Cielo. Pero cuando veas lo que el fantástico animal desencadena,

Action Notes

Detalle frontal de Anu

Seq	Scene	Panel
26	857	2

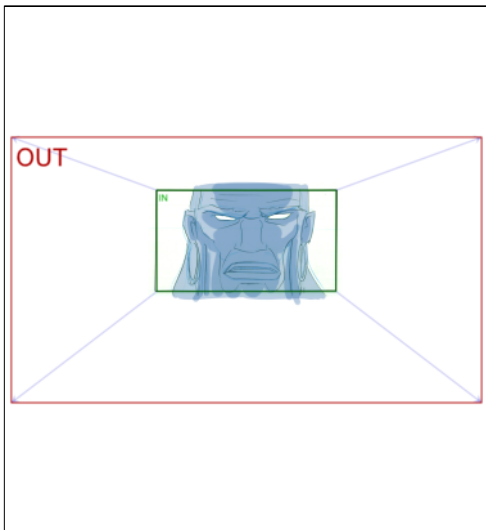

Dialog

ANÚ

recuerda que fue tu voluntad.

Action Notes

Sus ojos se tornan blancos y brillan

Seq	Scene	Panel
26	857	3

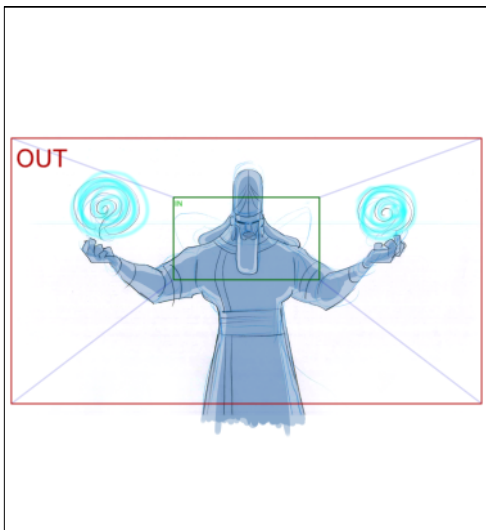

Action Notes

Zoom Out - Anu invoca al Toro de los Cielos

Seq	Scene	Panel
26	858	1



Action Notes

Una bruma gigantesca envuelve a Anu mientras la camara gira

Seq	Scene	Panel
26	858	2

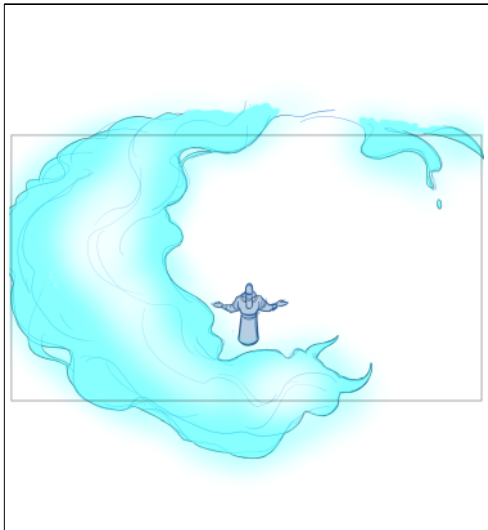

Action Notes

Una bruma gigantesca envuelve a Anu mientras la camara gira

Seq	Scene	Panel
26	858	3



Action Notes

La bruma toma la forma de los cuernos de un toro

Seq	Scene	Panel
26	858	4

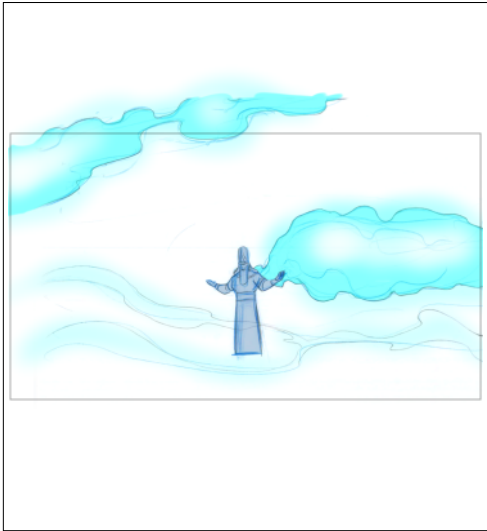

Action Notes
Y gira en torno al dios

Seq	Scene	Panel
26	858	5

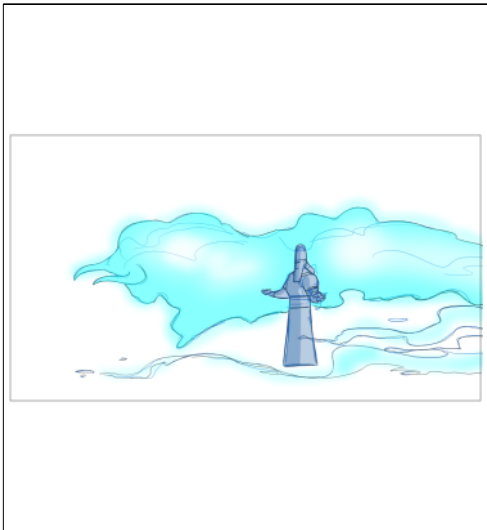

Action Notes
Y gira en torno al dios

Seq	Scene	Panel
26	858	6

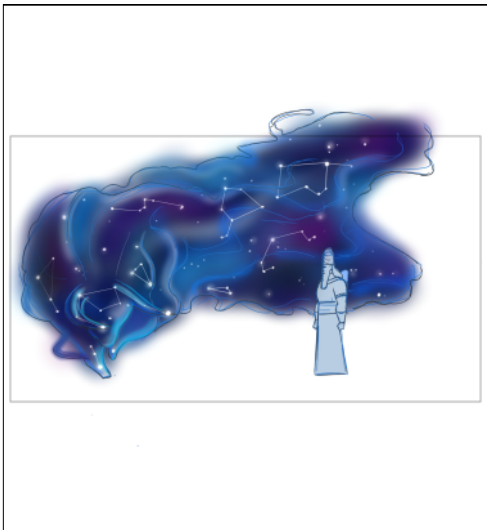

Action Notes
Y gira en torno al dios

Seq	Scene	Panel
26	858	7

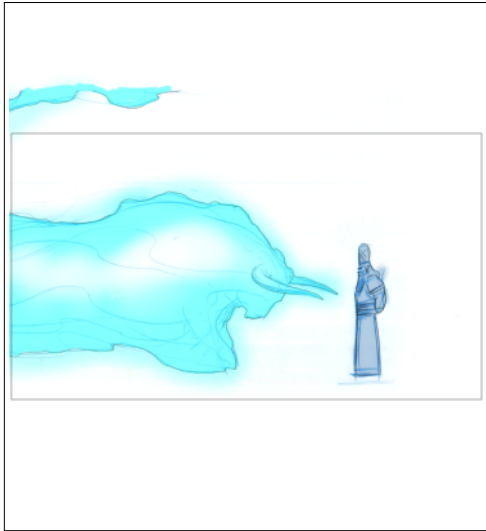

Action Notes

Hasta detenerse frente a el

Seq	Scene	Panel
26	858	8



Action Notes

Hasta detenerse frente a el

Seq	Scene	Panel
26	858	9

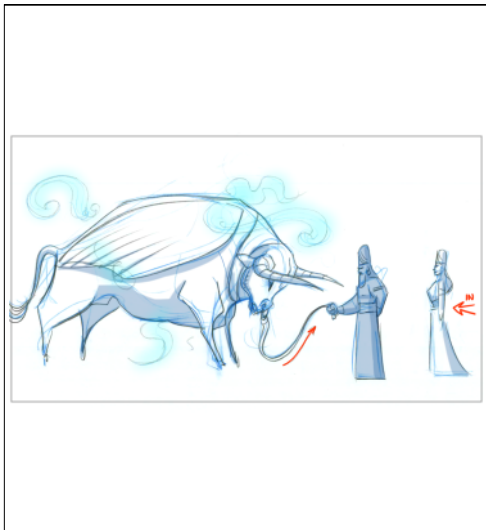

Action Notes

Y vemos surgir de entre la bruma al toro alado. Ishtar entra en cuadro
Una correa magica se extiende desde la nariz del toro hasta la mano de Anu

Seq	Scene	Panel
26	859	1

Action Notes
Anu toma la correa de toro

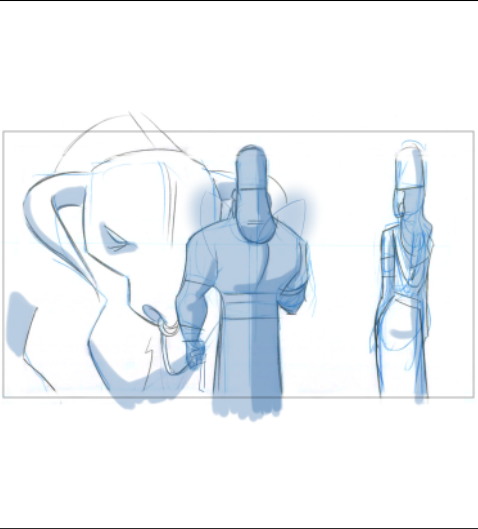

Seq	Scene	Panel
26	859	2

Action Notes
Y se la entrega a Ishtar

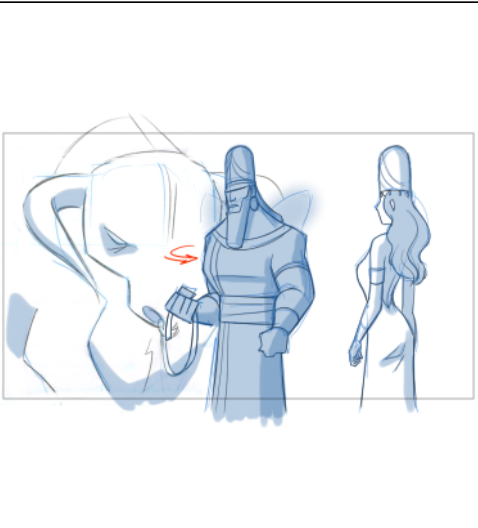

Seq	Scene	Panel
26	859	3

Action Notes
Y se la entrega a Ishtar





Seq	Scene	Panel
26	860	1

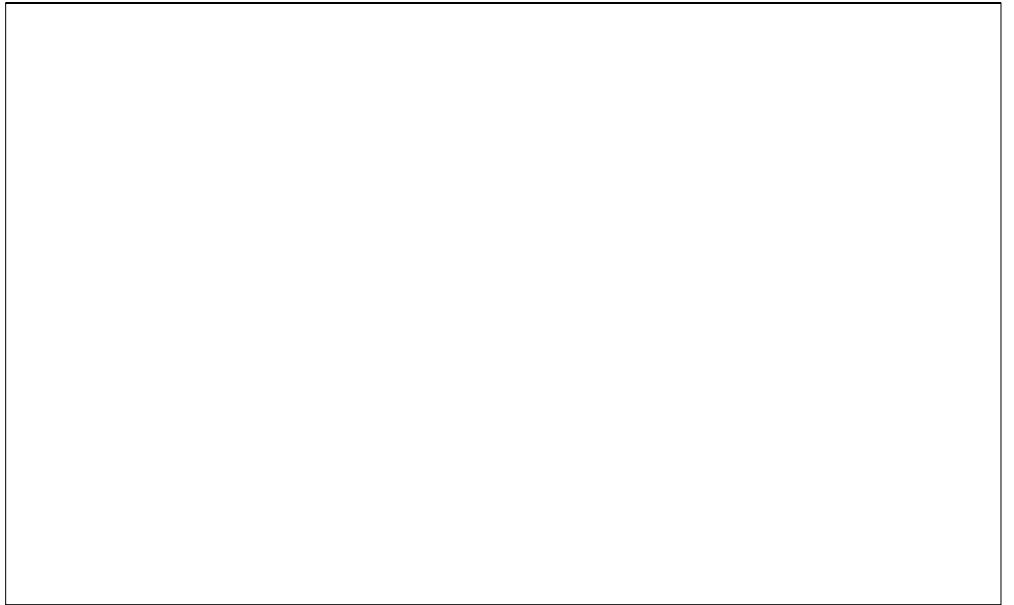
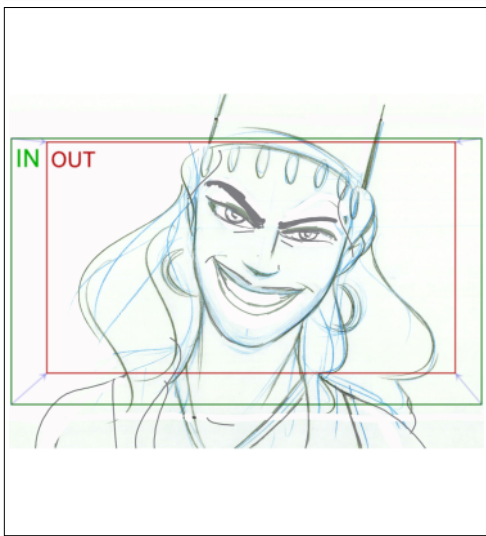

Seq	Scene	Panel
27	861	1

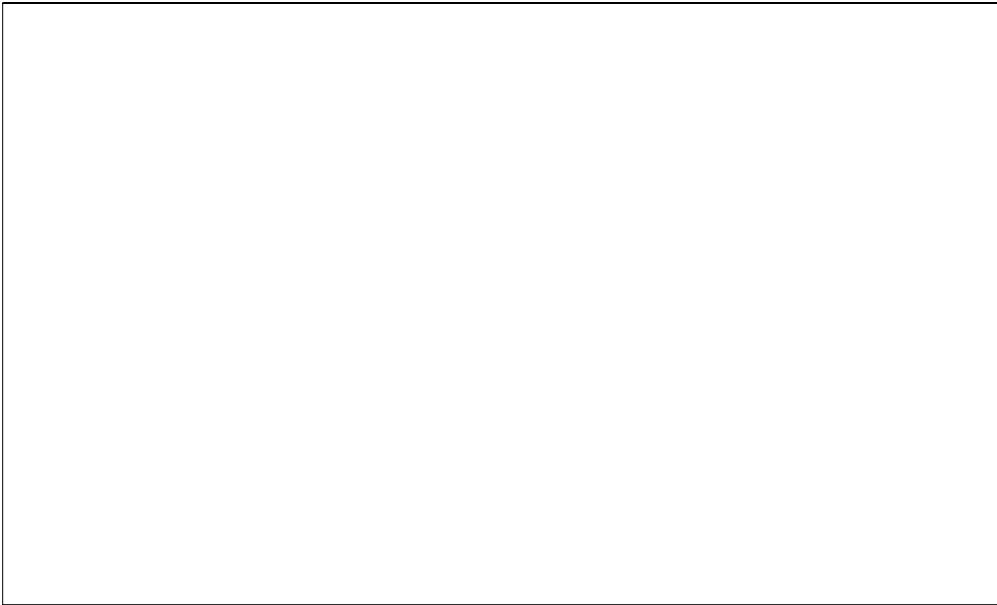
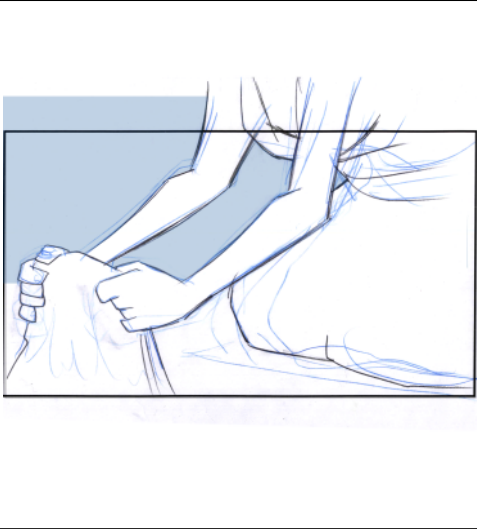

Seq	Scene	Panel
27	862	1

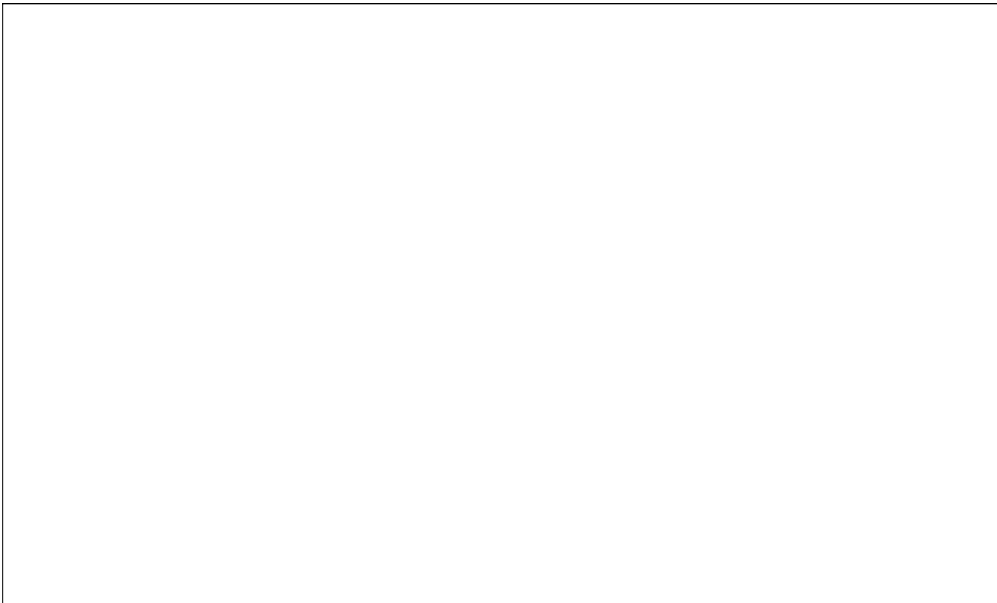

Seq	Scene	Panel
27	863	1

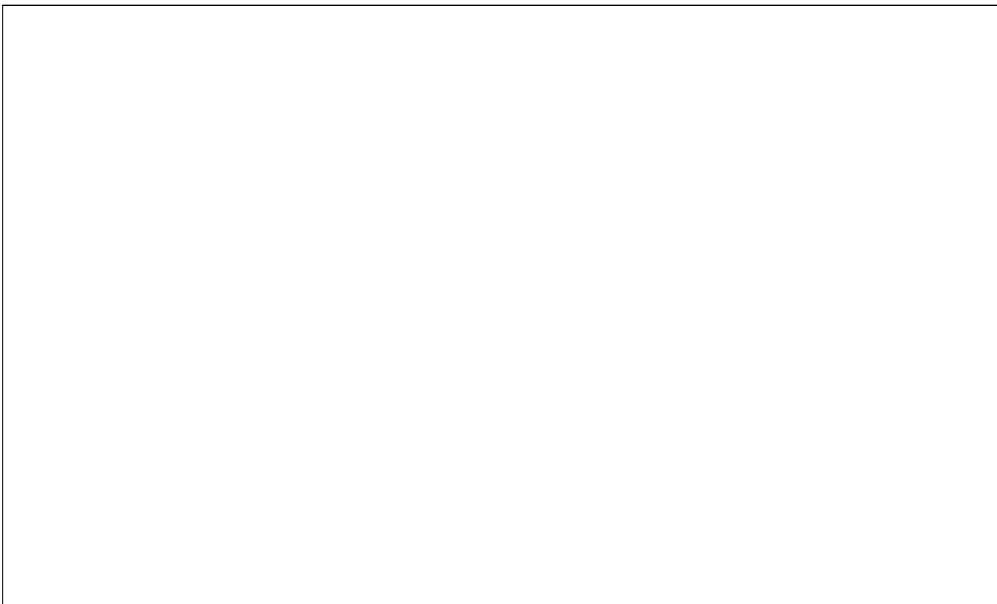
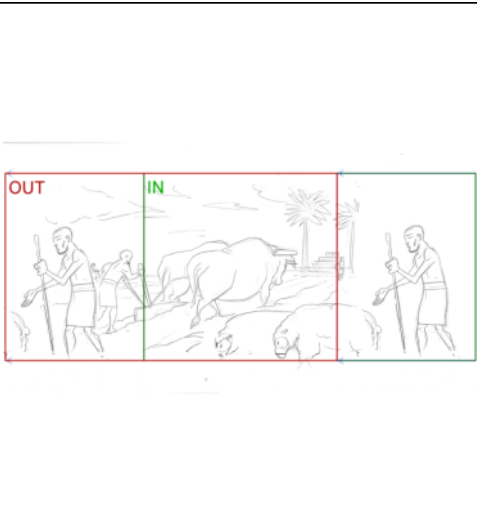

Seq	Scene	Panel
27	863	2



Seq	Scene	Panel
27	864	1

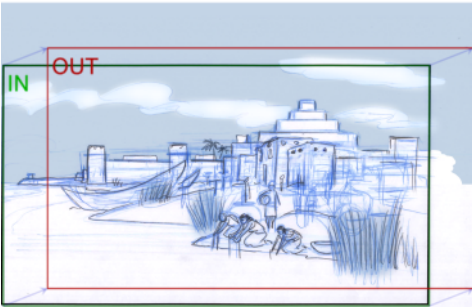

Seq	Scene	Panel
27	864	2

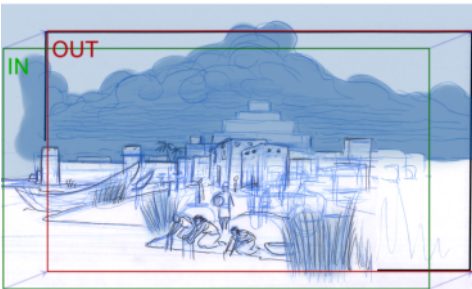

Seq	Scene	Panel
27	864	3

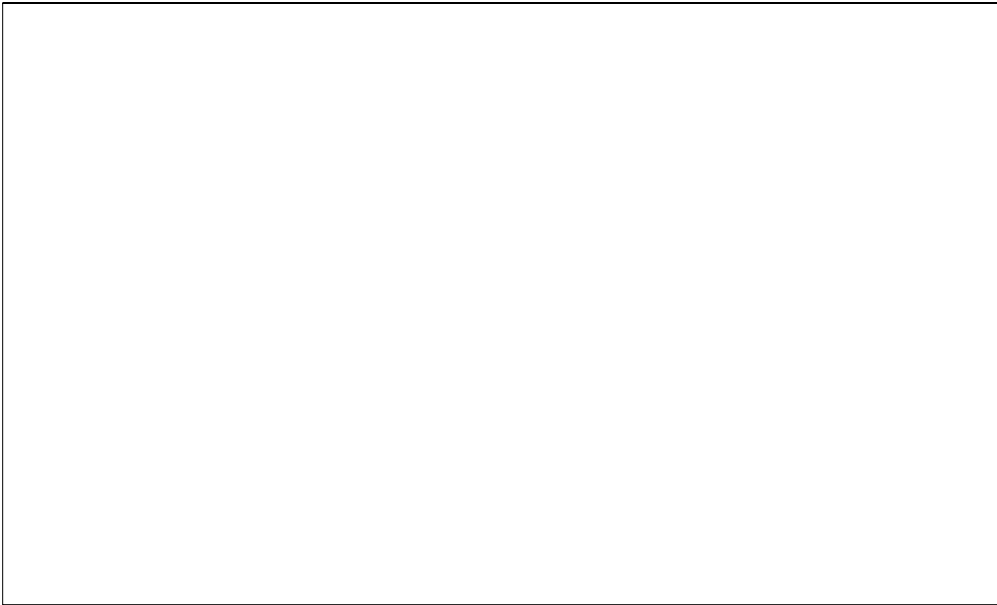
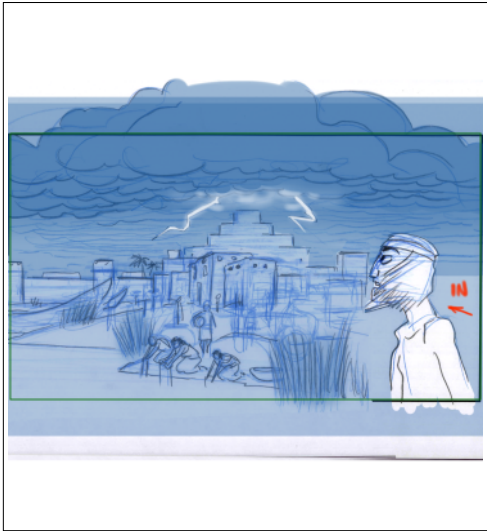

Seq	Scene	Panel
27	865	1

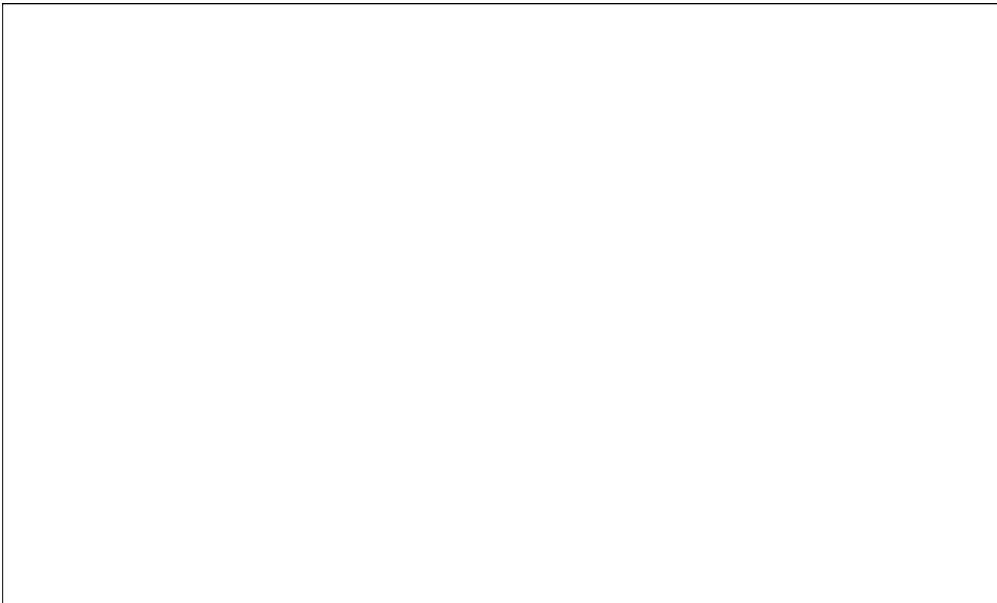
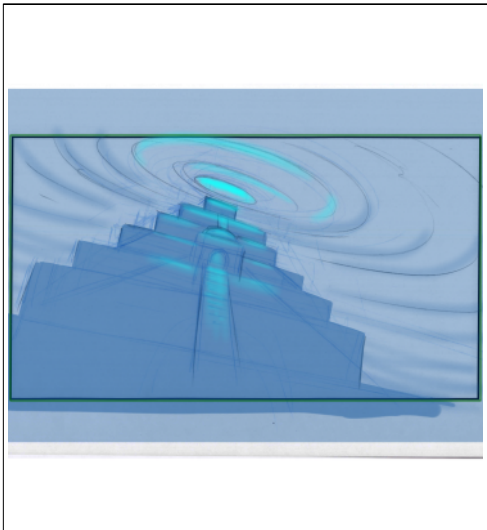

Seq	Scene	Panel
27	865	2

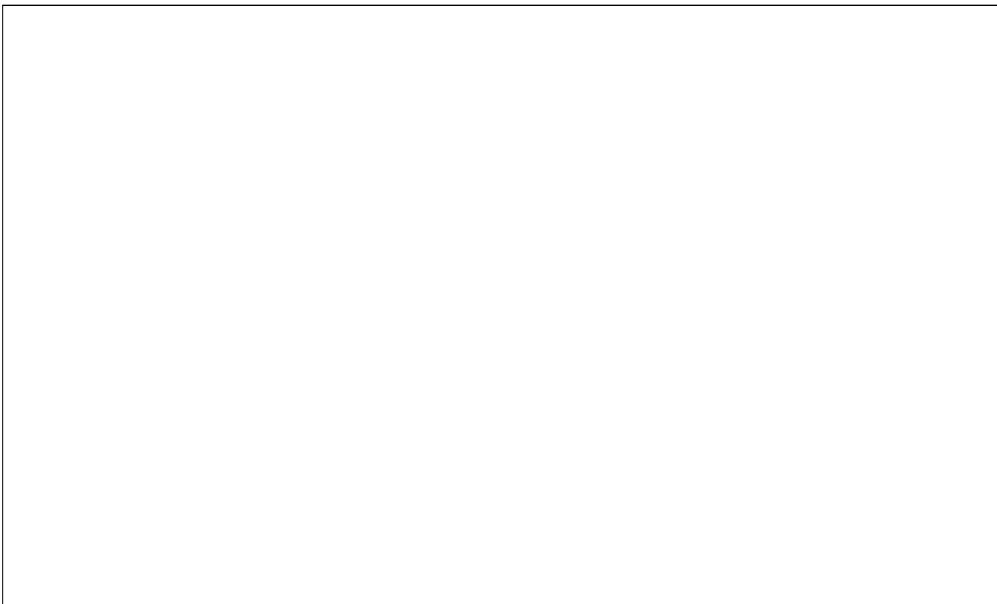
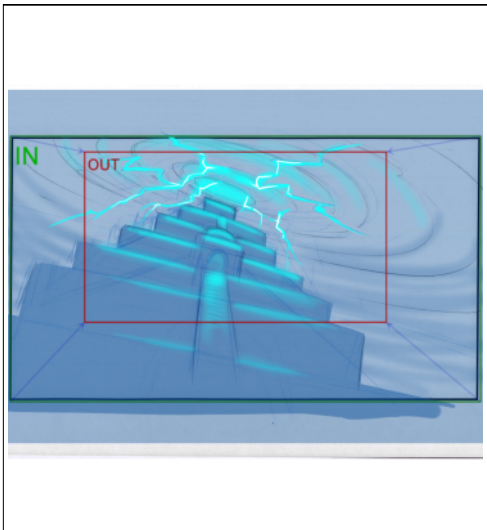

Seq	Scene	Panel
27	865	3

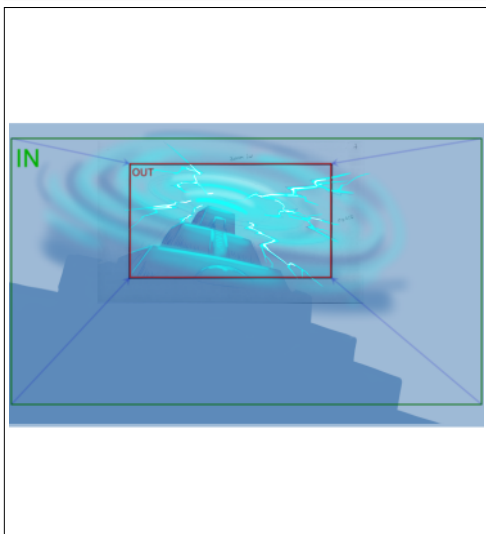

Seq	Scene	Panel
27	866	1

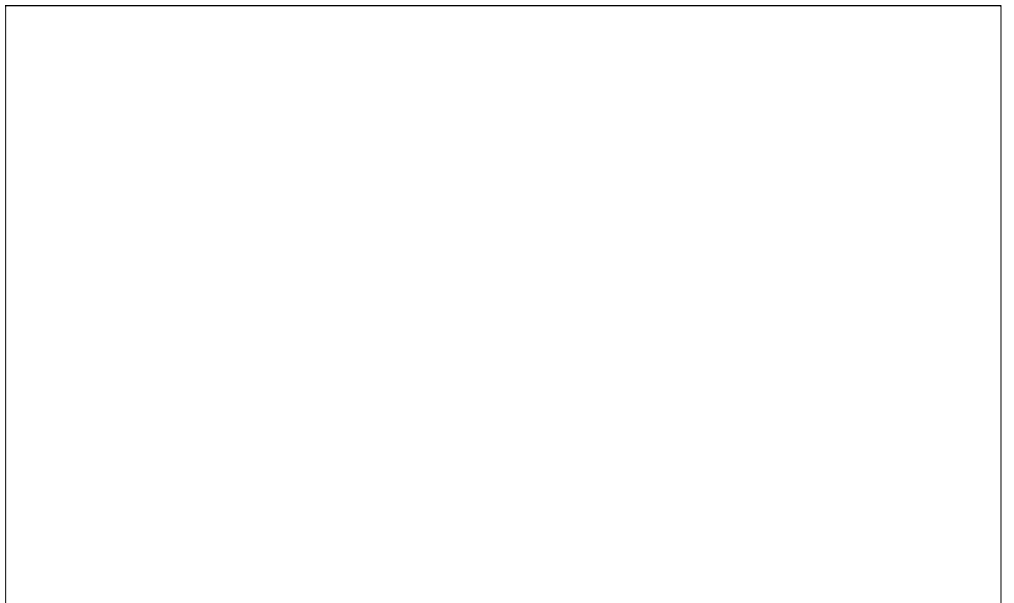
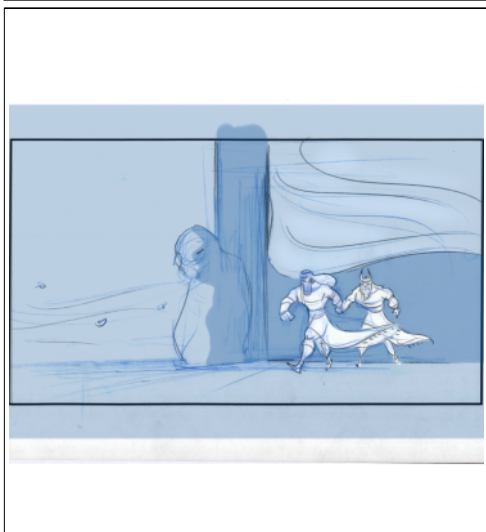

Seq	Scene	Panel
27	867	1

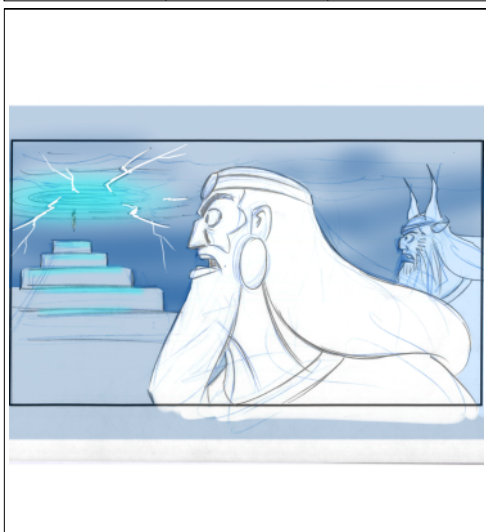

Dialog

ENKIDU:
"QUÉ SUCEDE?"

GILGAMESH:
"TEMO QUE ES UNA VENGANZA DE ISHTAR."

Seq	Scene	Panel
27	868	1

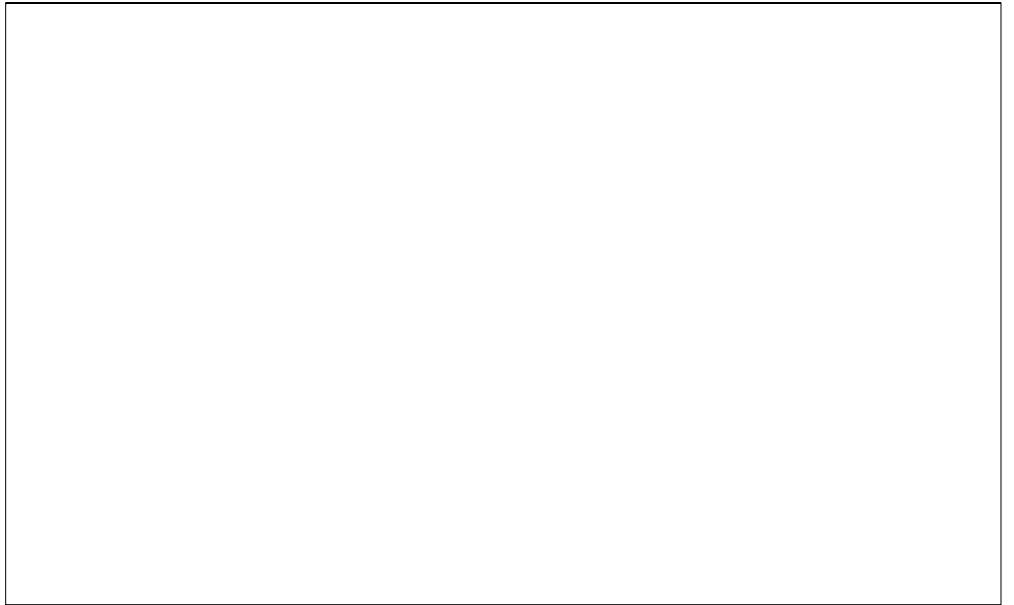
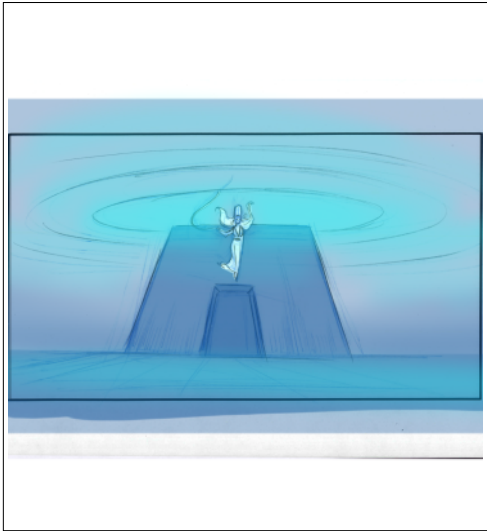

Seq	Scene	Panel
27	868	2

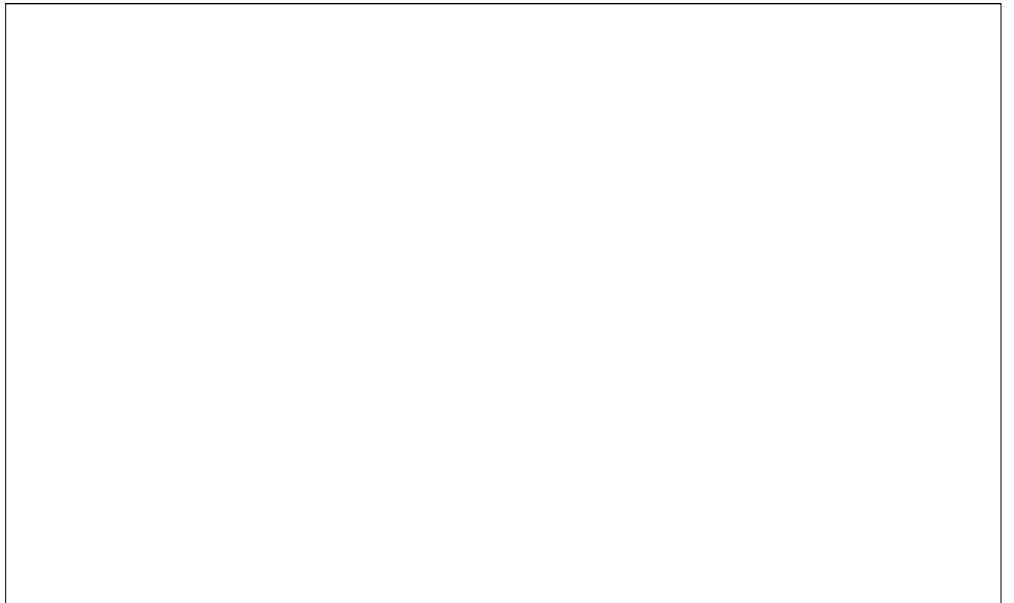
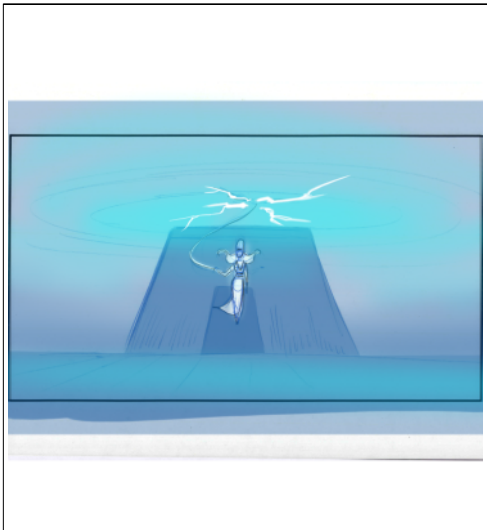

Seq	Scene	Panel
27	869	1

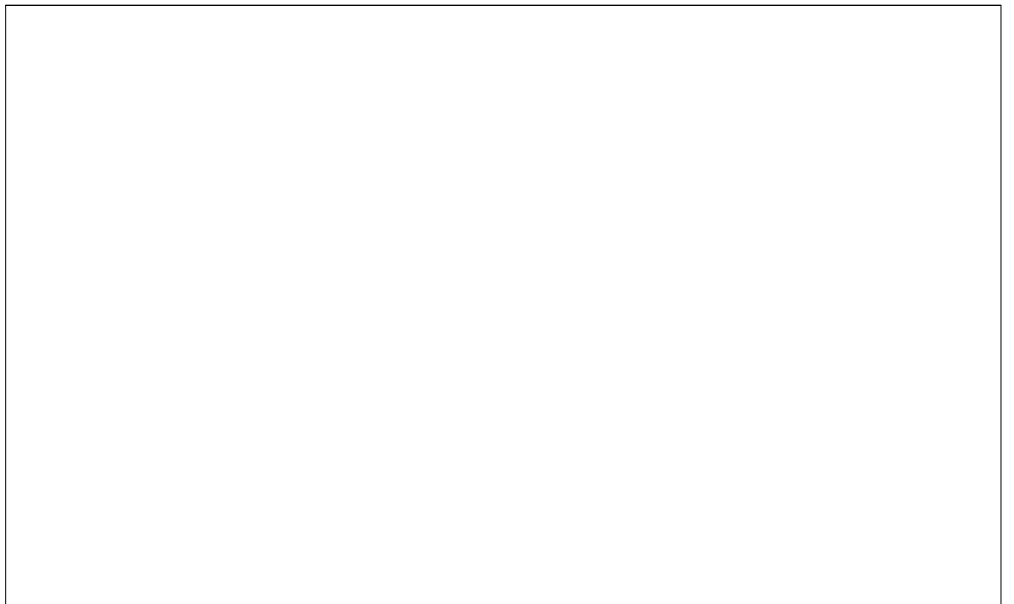
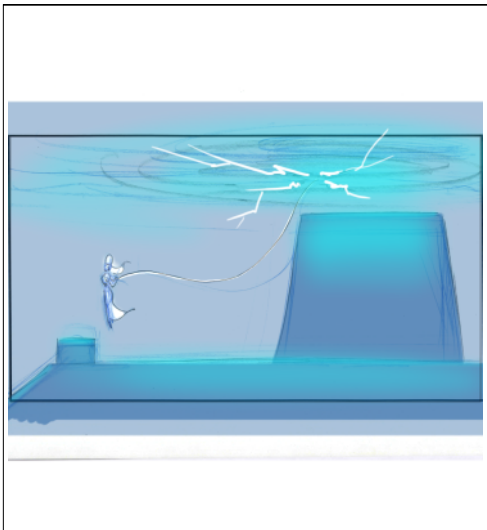

Seq	Scene	Panel
27	869	2

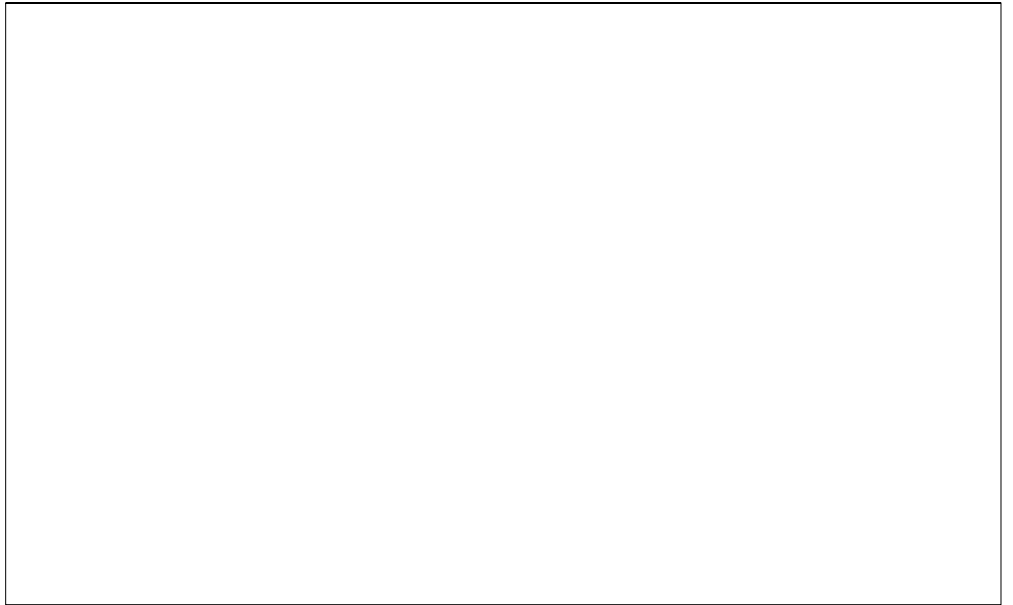
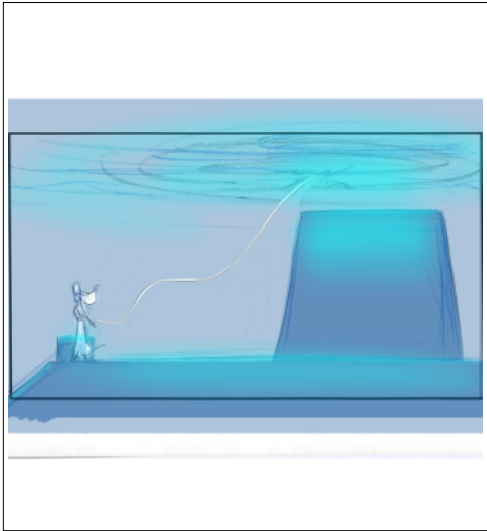

Seq	Scene	Panel
27	870	1

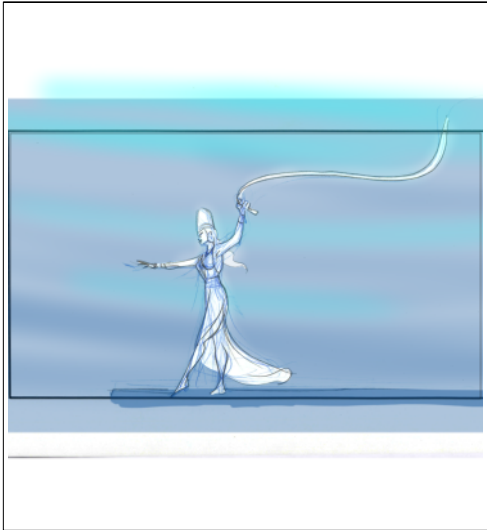

Seq	Scene	Panel
27	870	2

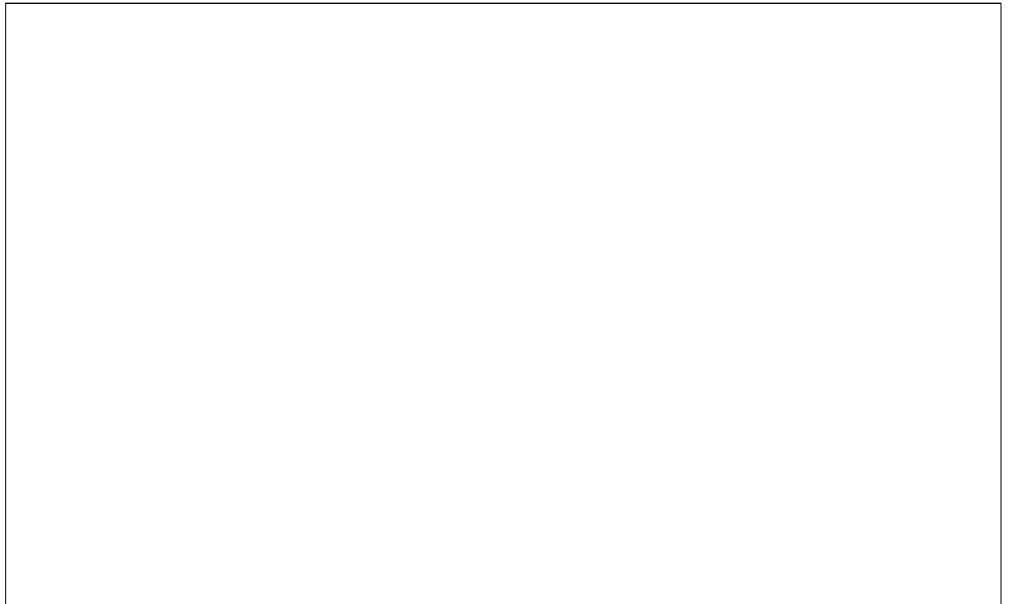

Seq	Scene	Panel
27	871	1



Seq	Scene	Panel
27	872	1

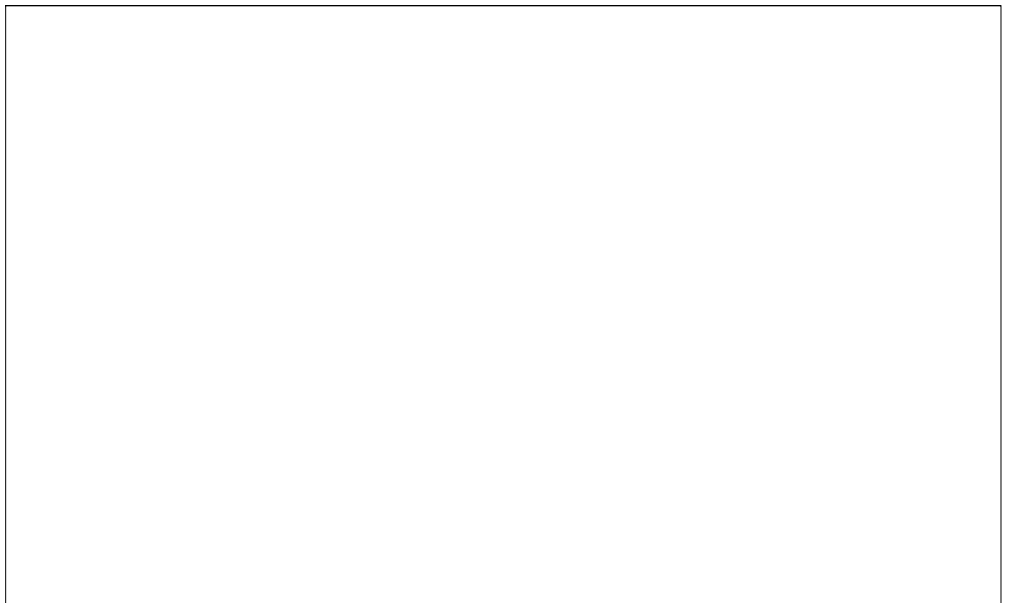
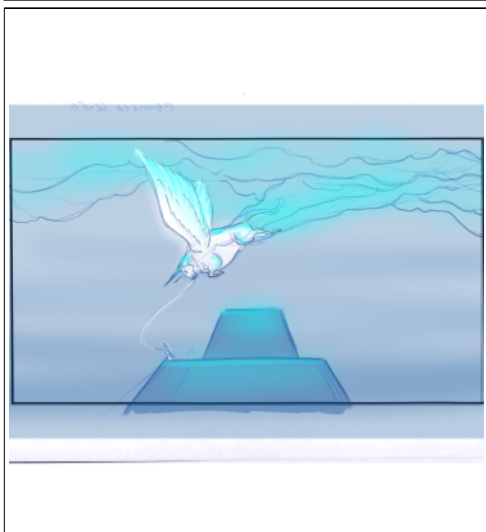

Seq	Scene	Panel
27	873	1

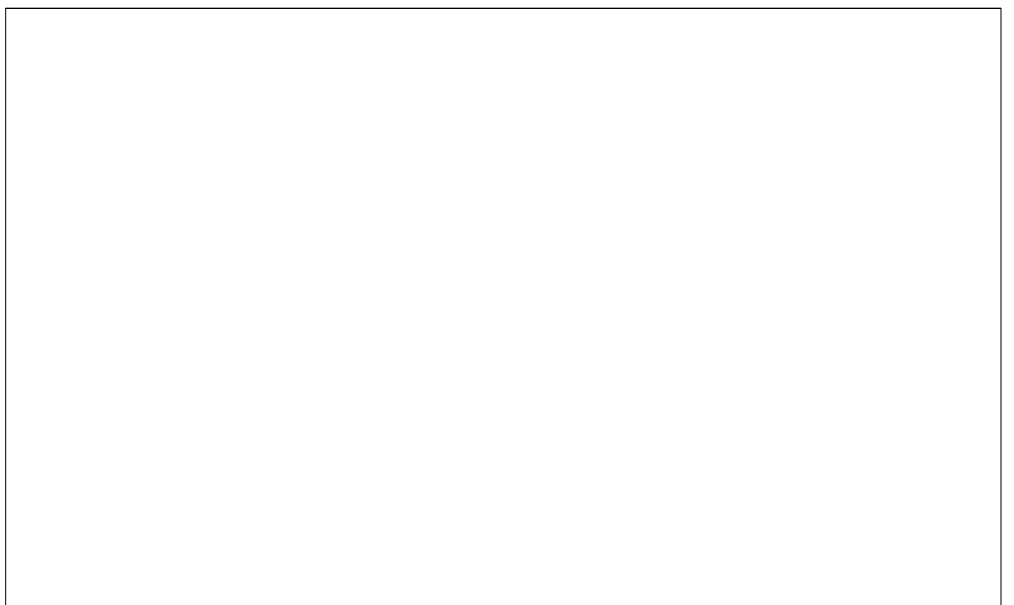
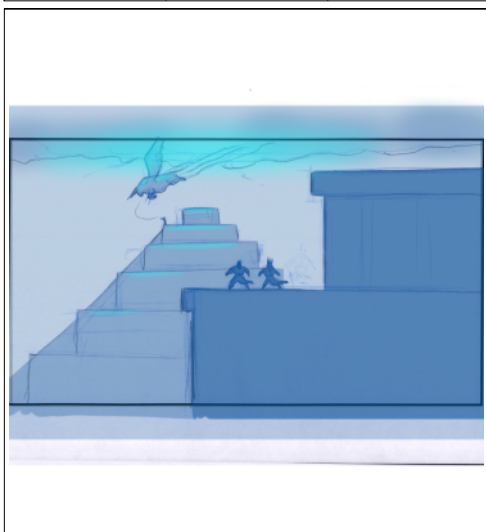

Seq	Scene	Panel
27	874	1

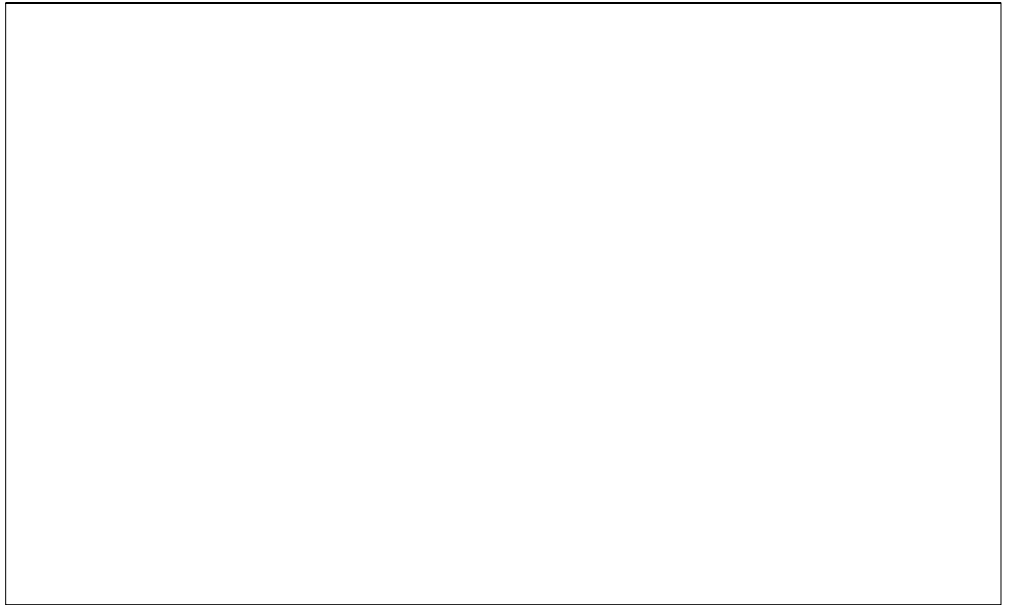
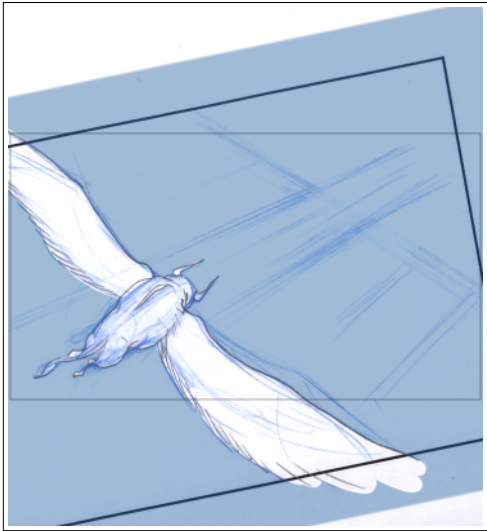

Seq	Scene	Panel
27	874	2

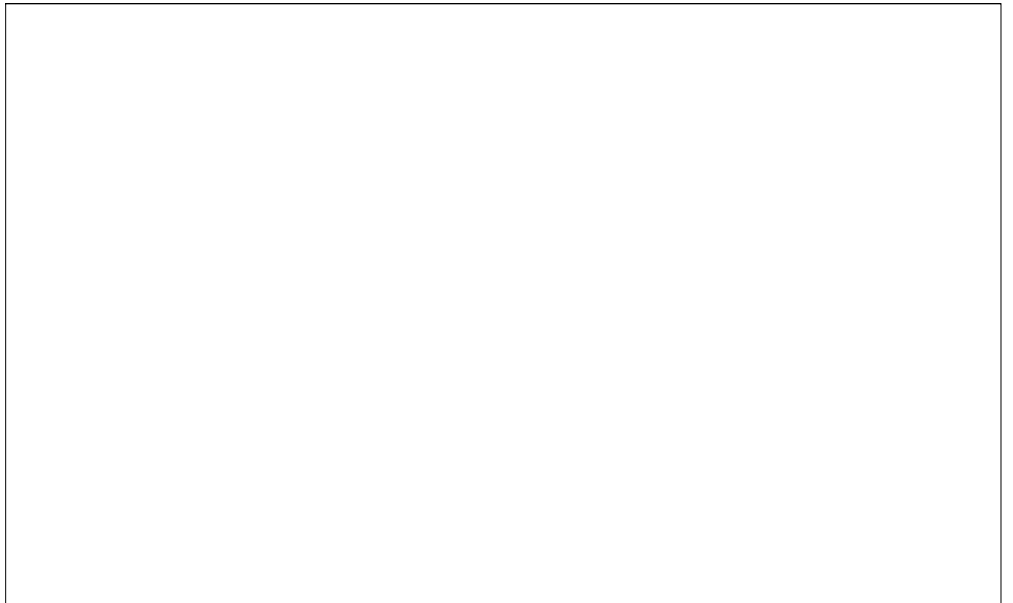
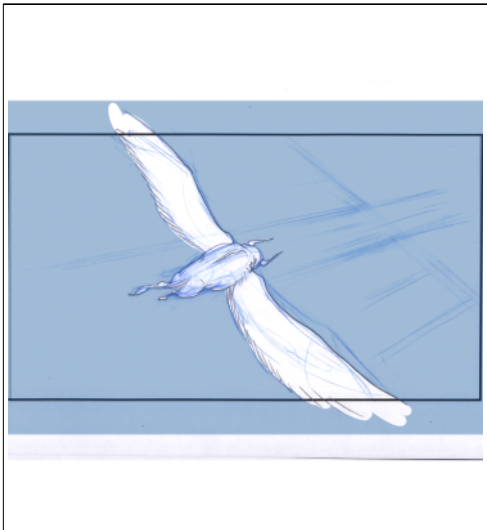

Seq	Scene	Panel
27	875	1

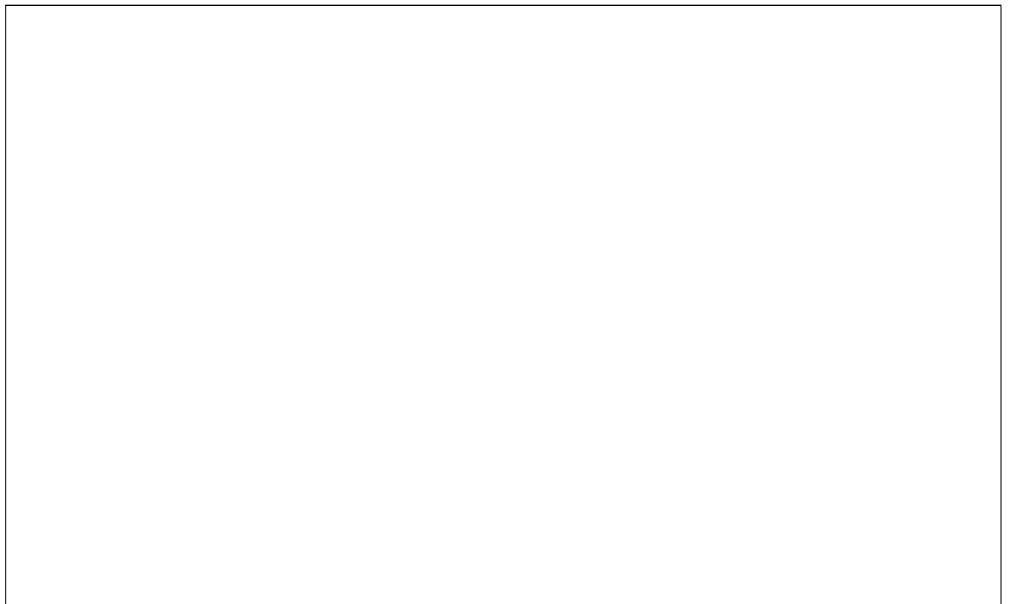
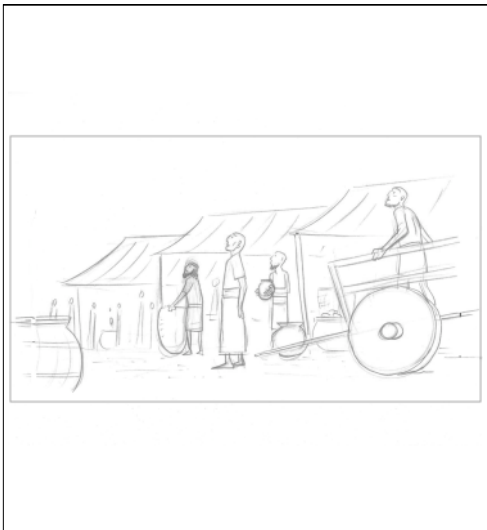

Seq	Scene	Panel
27	876	1

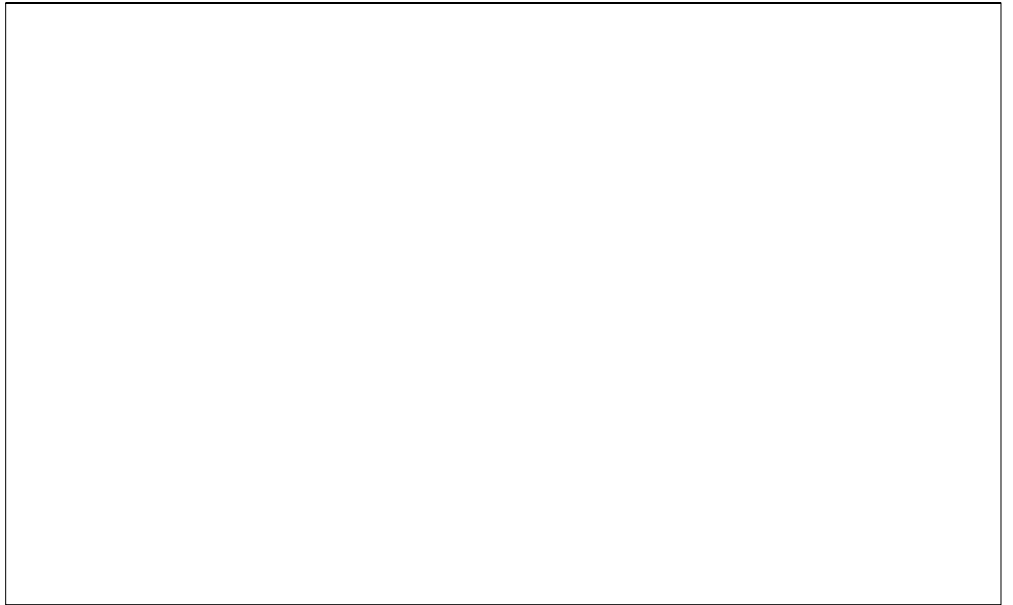
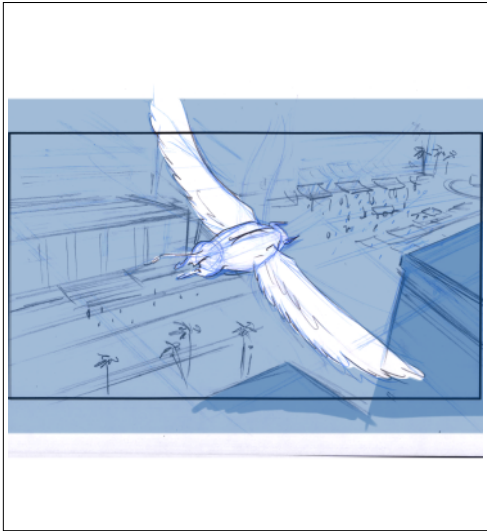

Seq	Scene	Panel
27	876	2

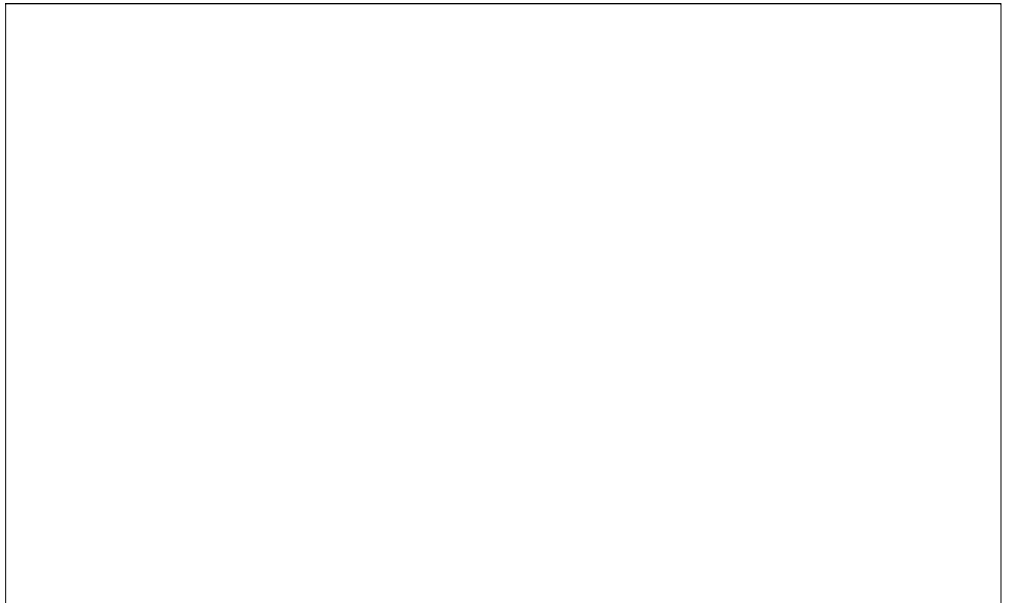
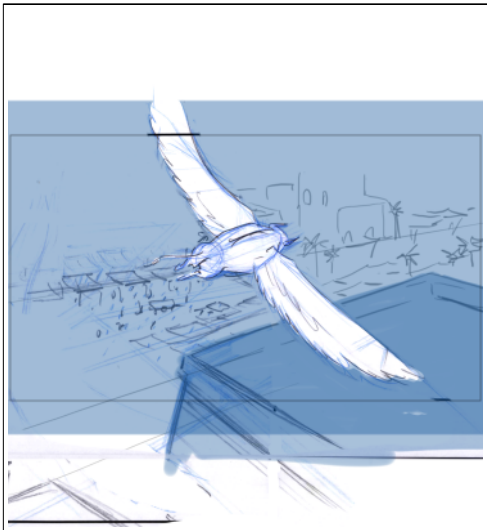

Seq	Scene	Panel
27	877	1

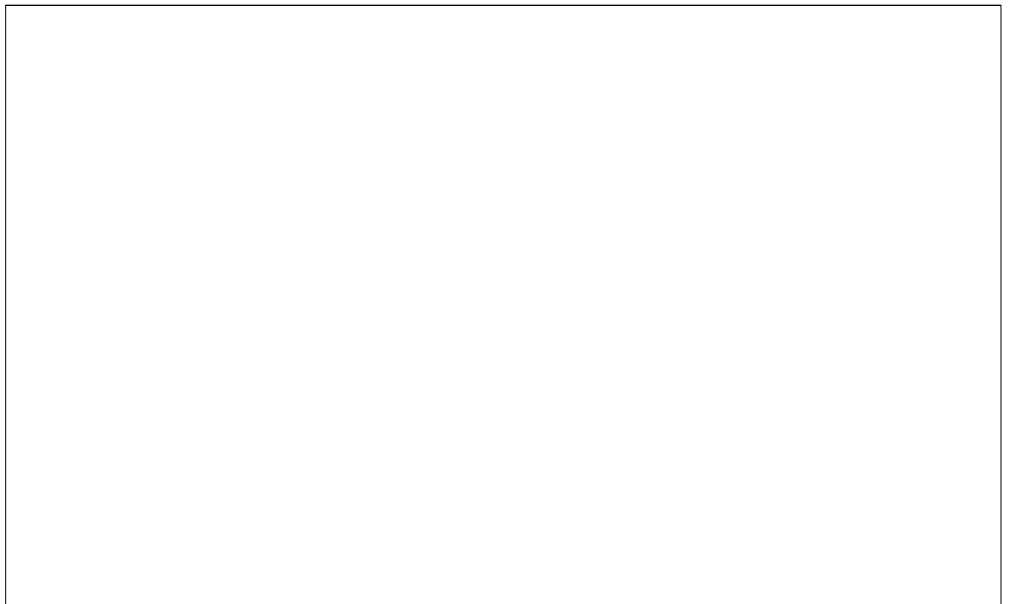

Seq	Scene	Panel
27	878	1

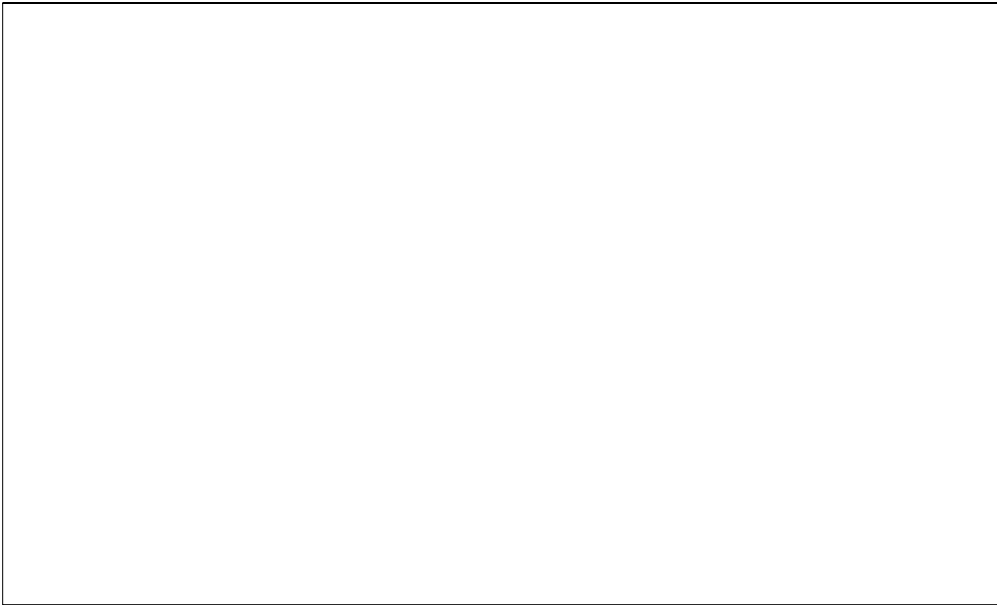
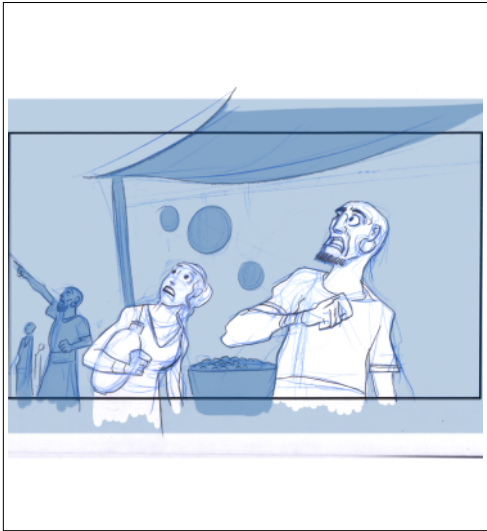

Seq	Scene	Panel
27	879	1

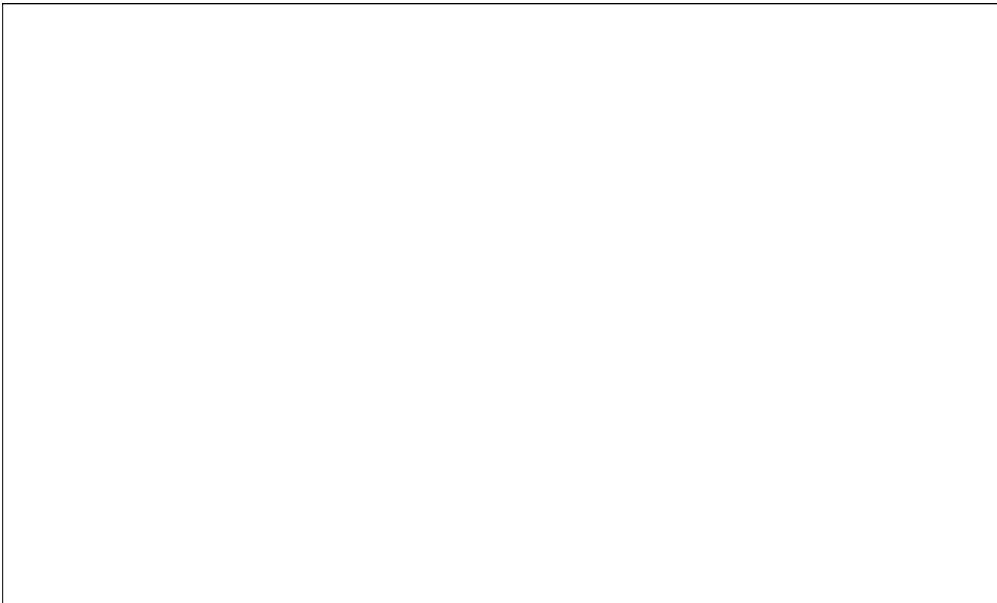
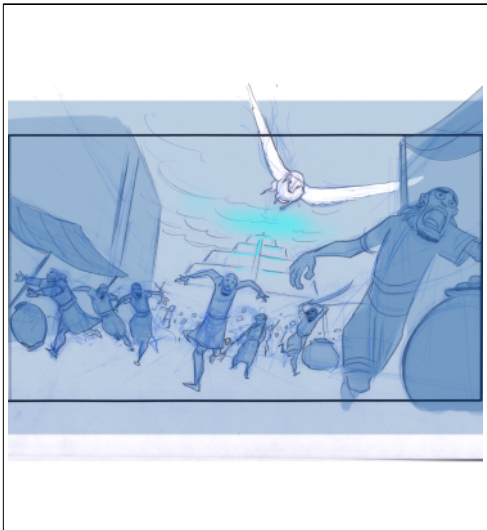

Seq	Scene	Panel
27	879	2

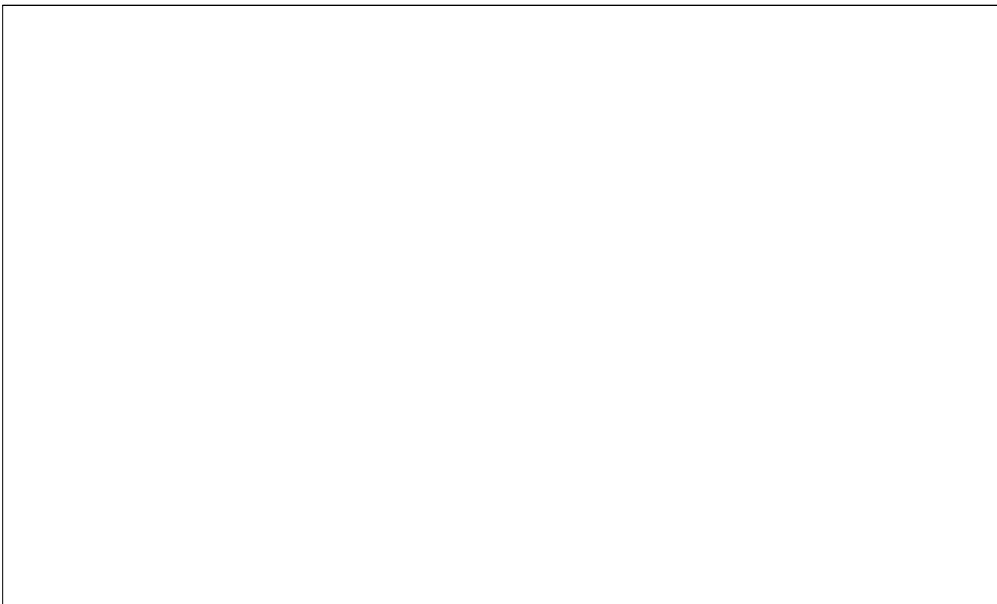
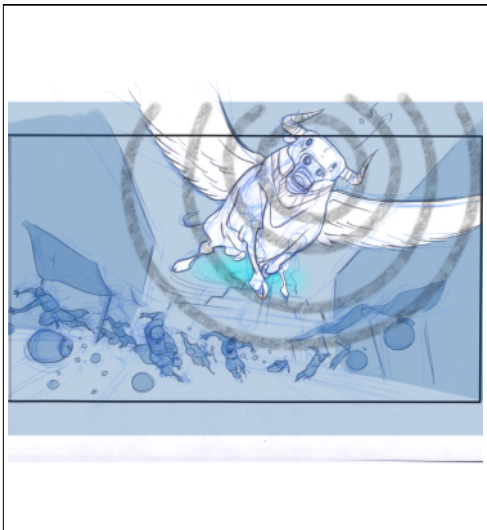

Seq	Scene	Panel
27	880	1

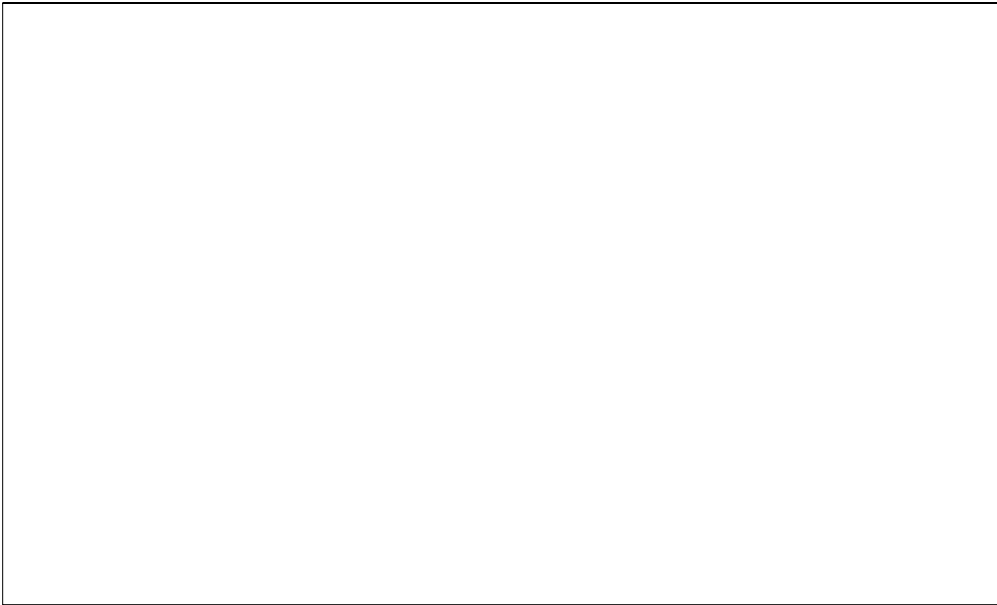
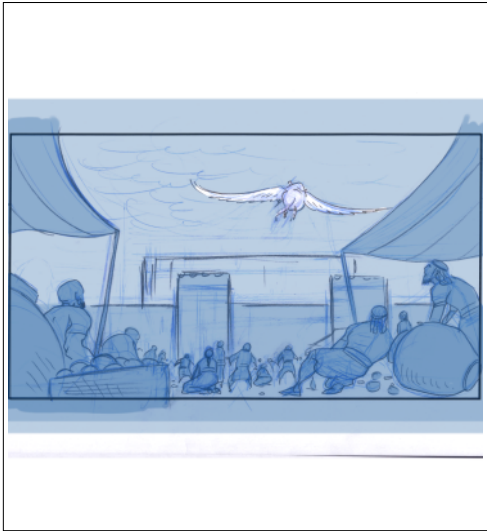

Seq	Scene	Panel
27	881	1

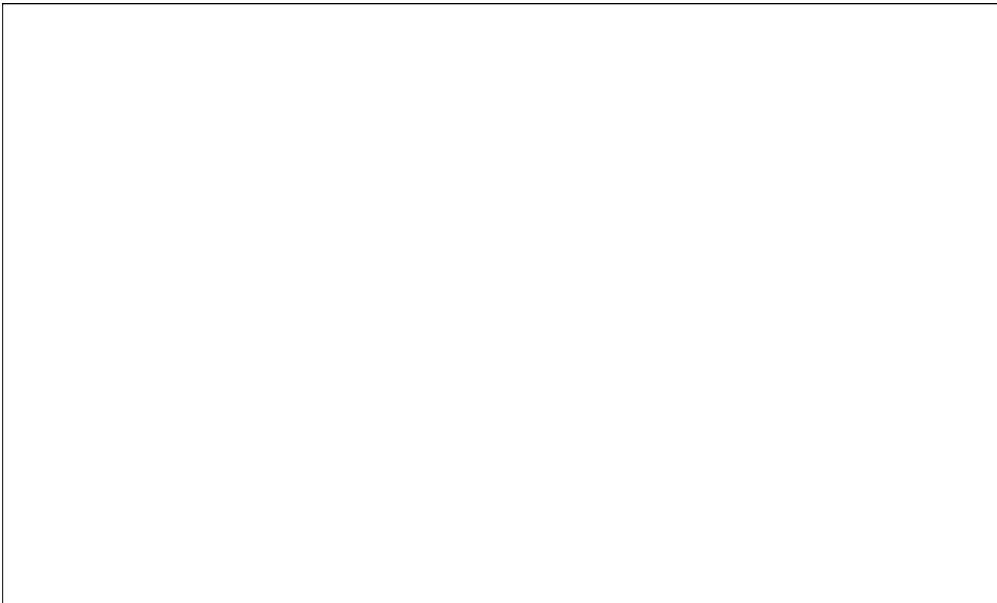

Seq	Scene	Panel
27	881	2

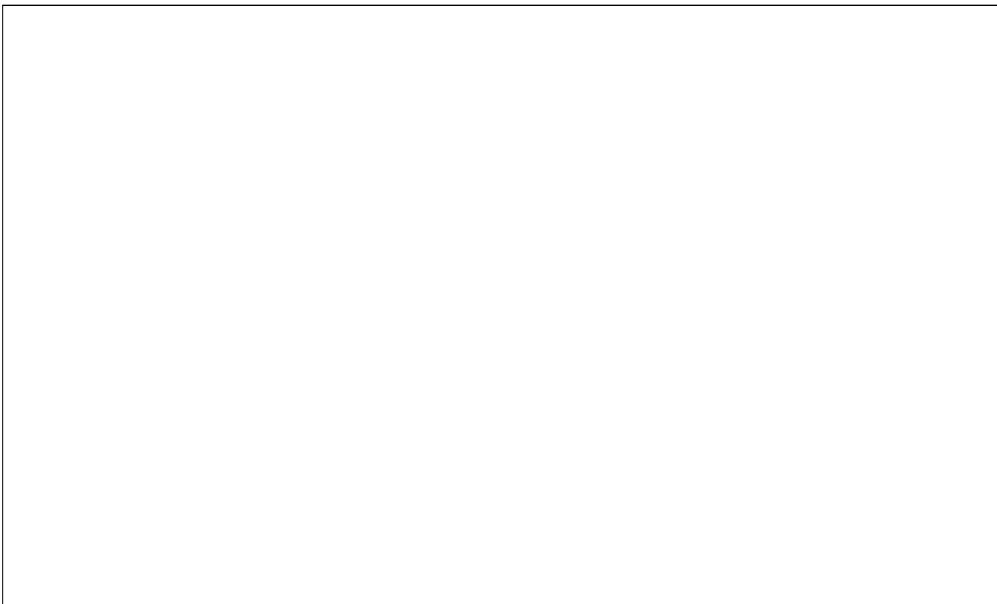
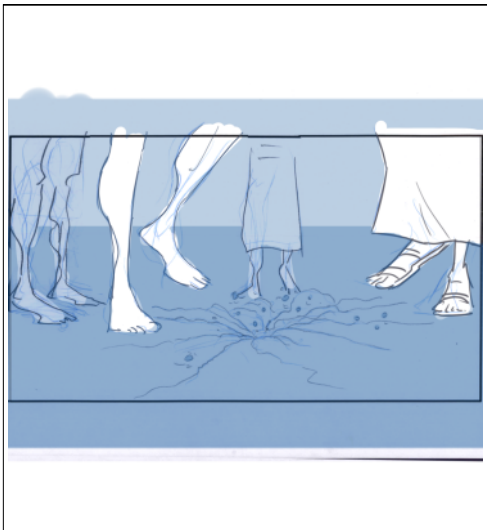

Seq	Scene	Panel
27	882	1

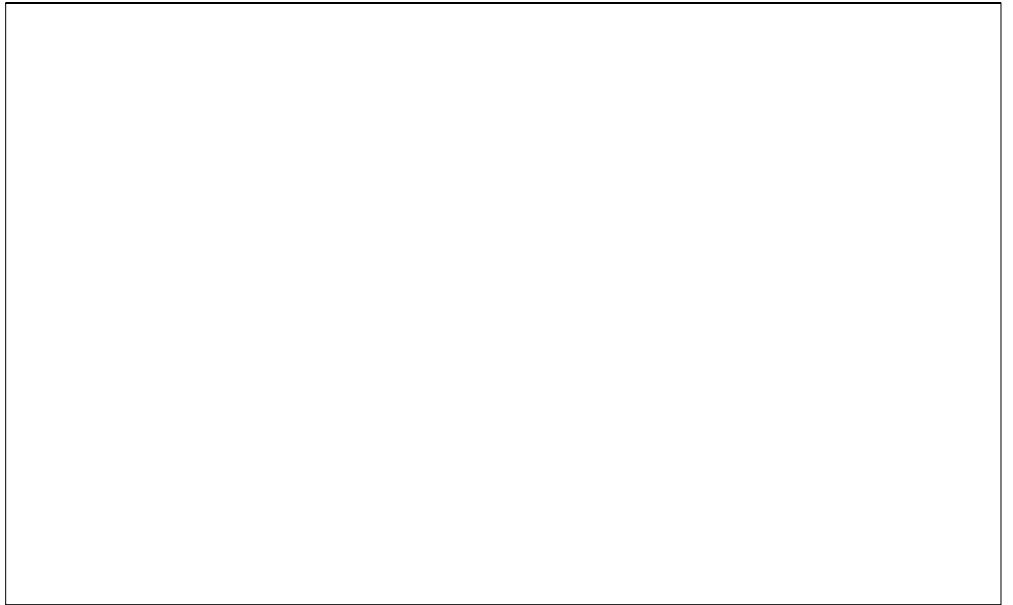
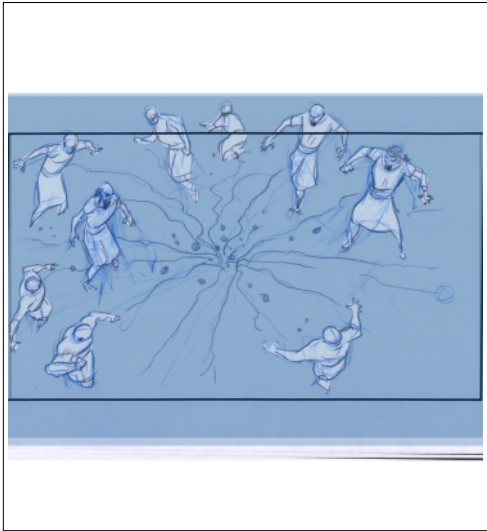

Seq	Scene	Panel
27	882	2

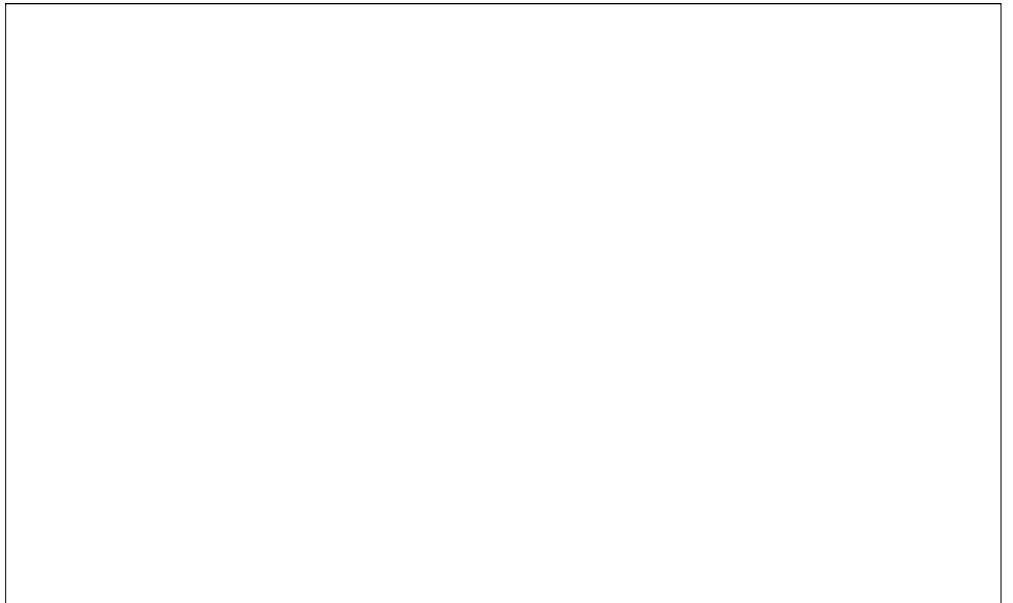
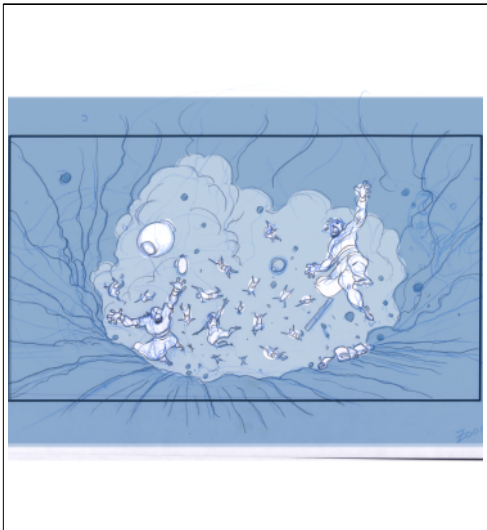

Seq	Scene	Panel
27	883	1

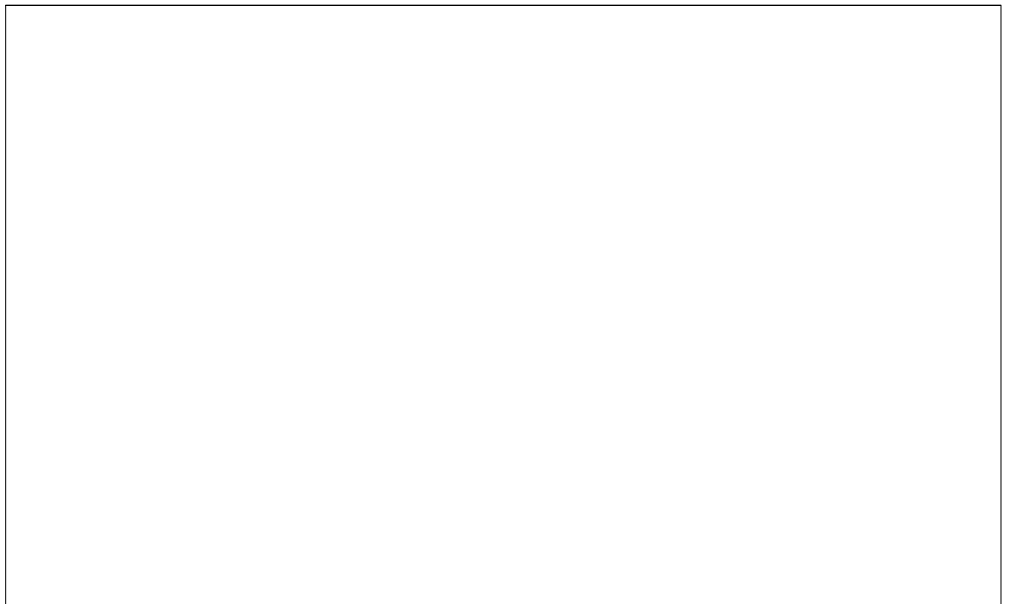
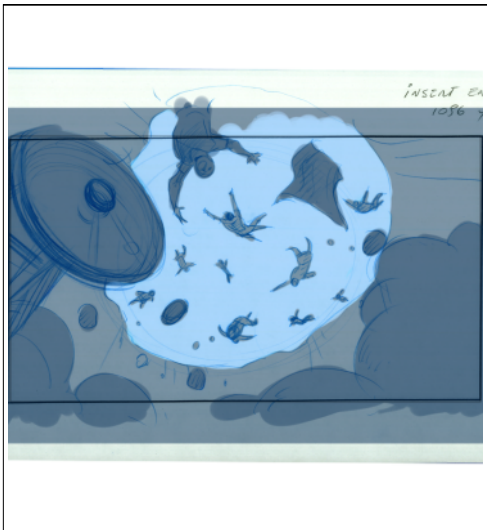

Seq	Scene	Panel
27	883	2

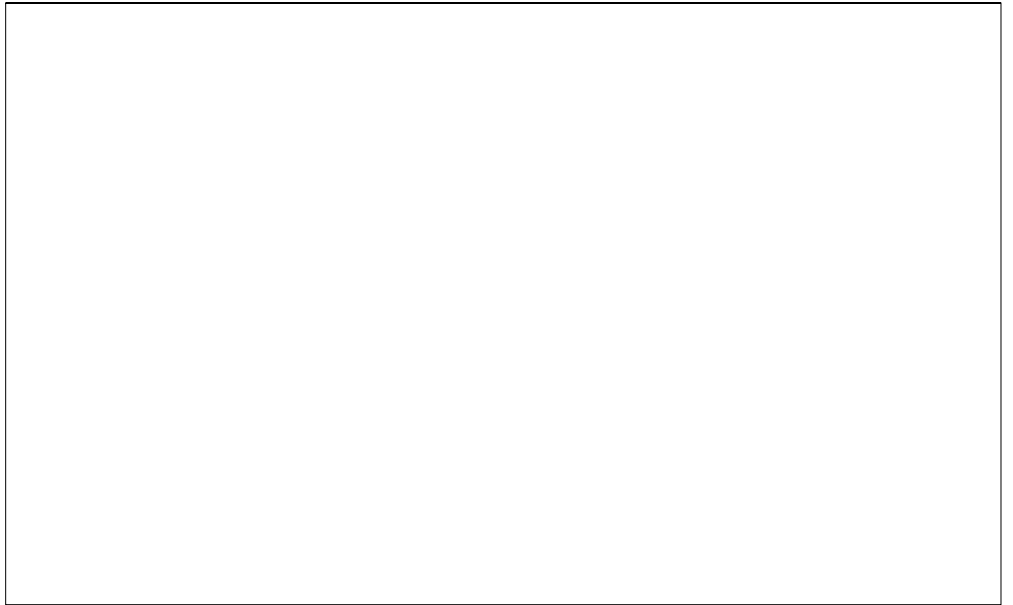
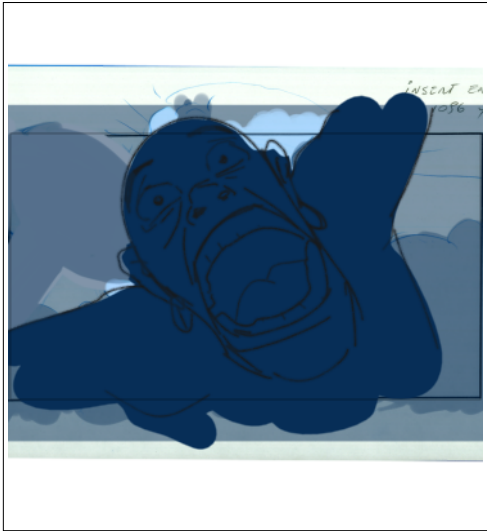

Seq	Scene	Panel
27	884	1

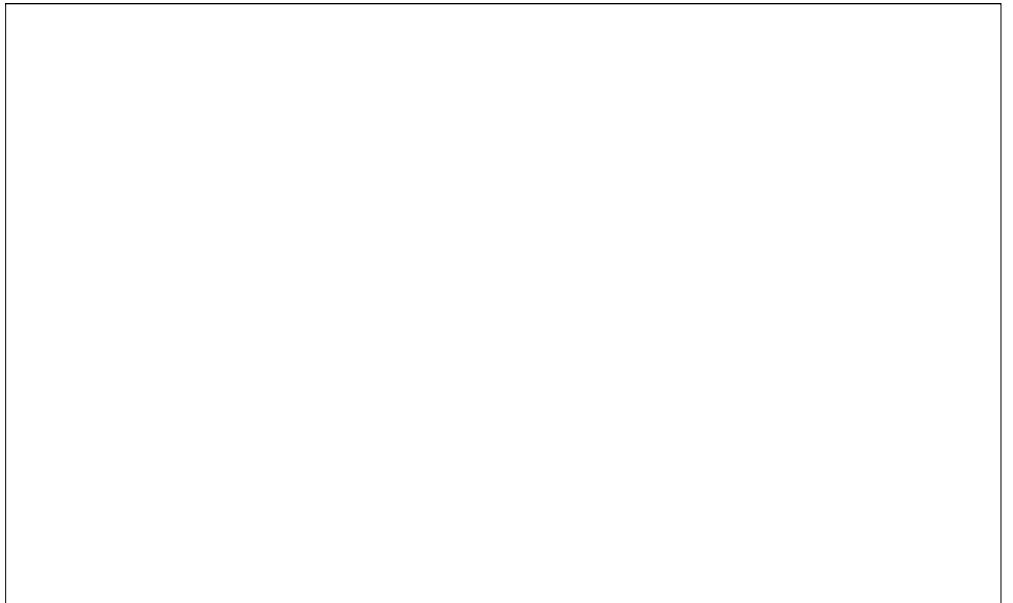
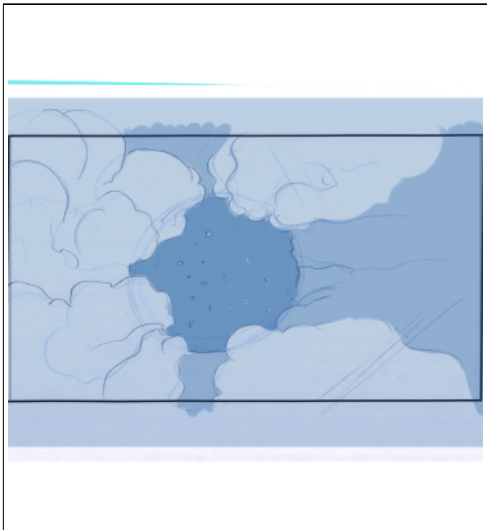

Seq	Scene	Panel
27	885	1

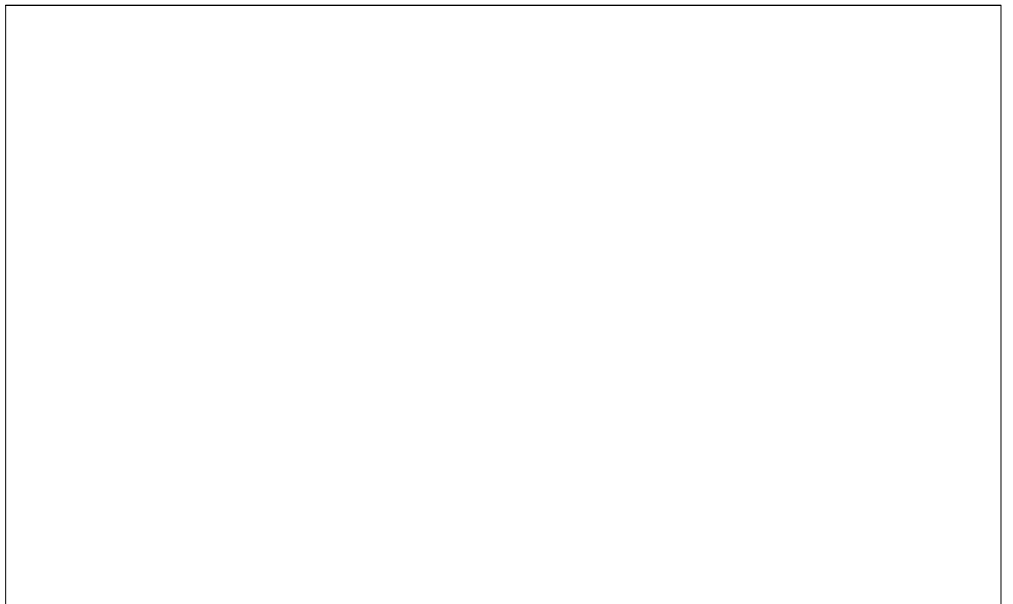
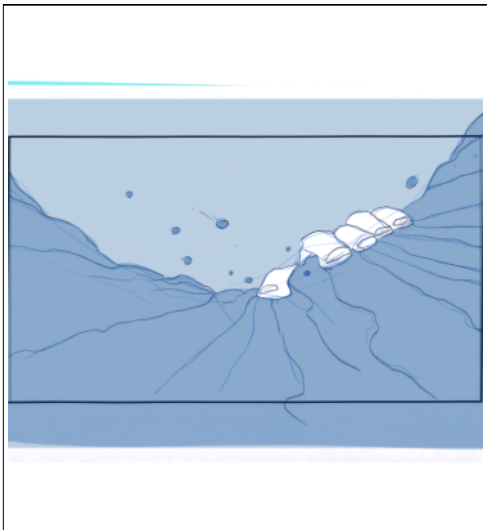

Seq	Scene	Panel
27	885	2

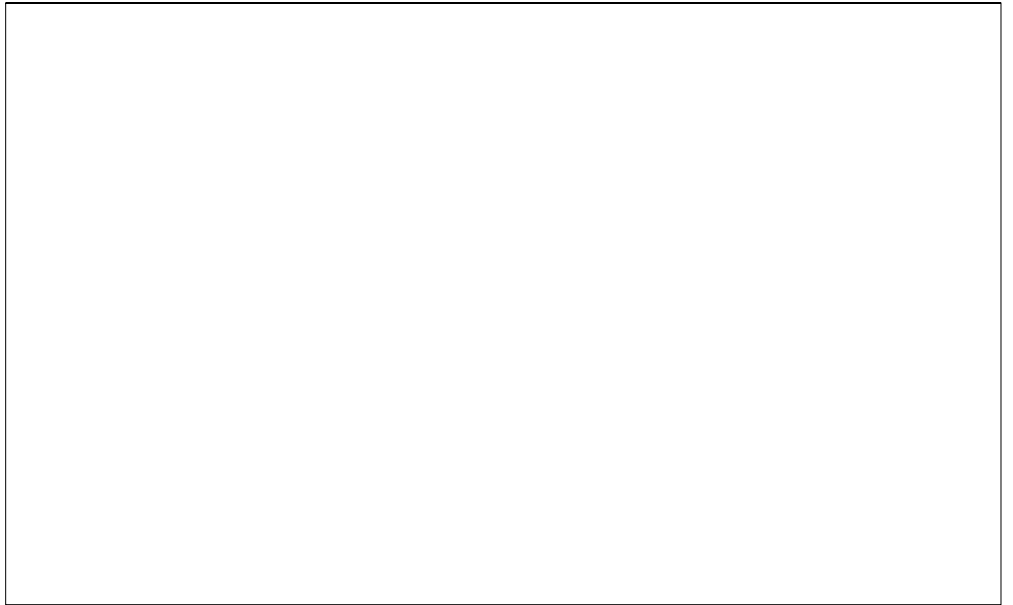
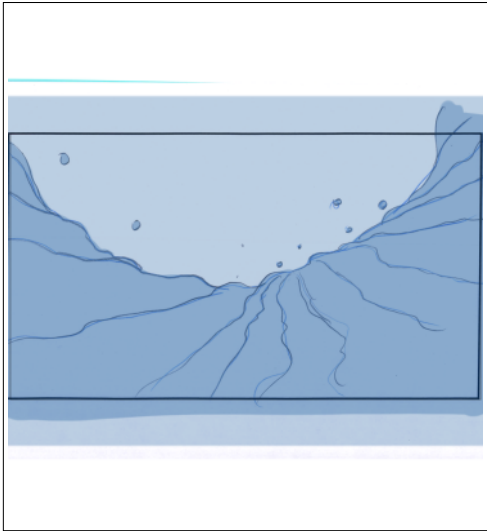

Seq	Scene	Panel
27	886	1

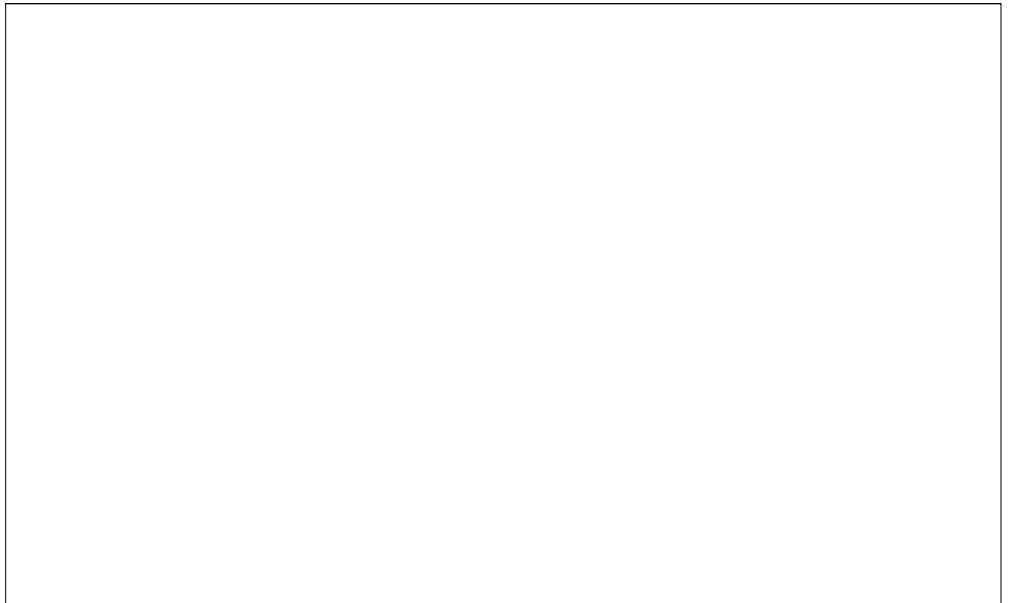
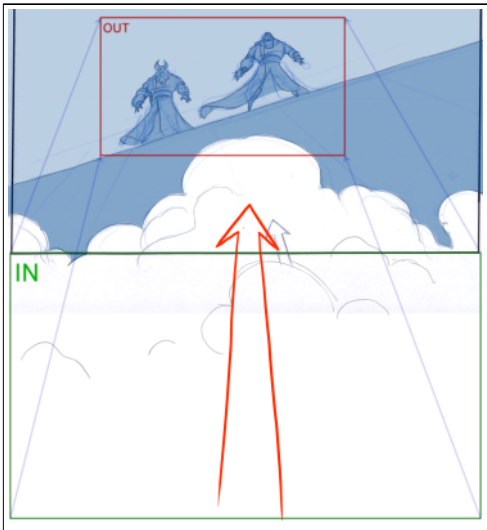

Seq	Scene	Panel
27	886	2

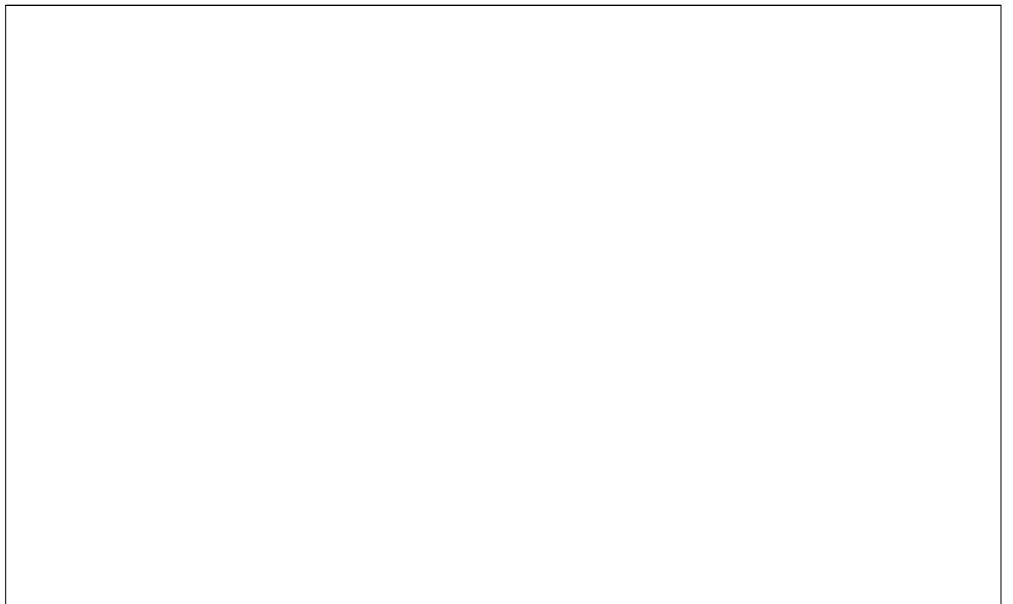
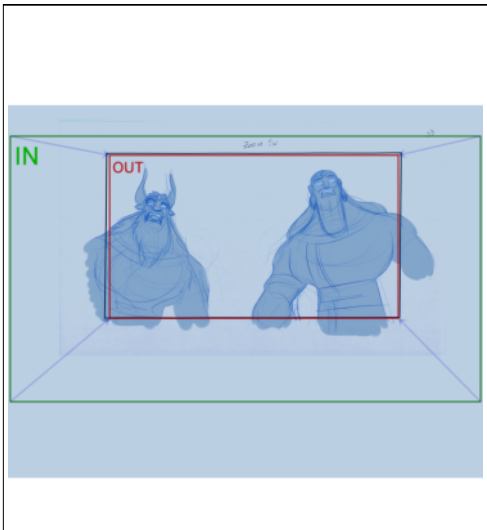

Seq	Scene	Panel
27	886	3

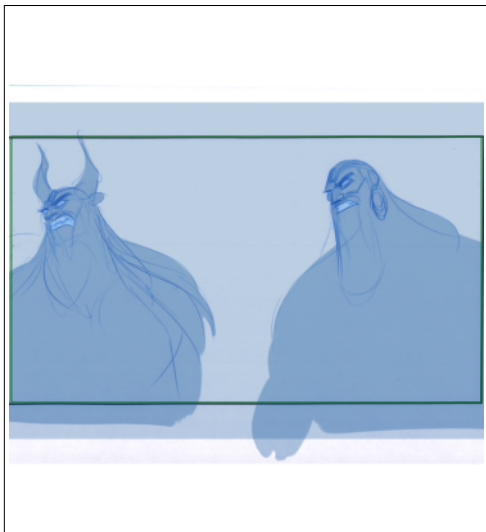

Dialog
GILGAMESH:
"ISHTAR, SERPIENTE VENENOSA,"

Seq	Scene	Panel
27	887	1



Dialog
GILGAMESH EN OFF:
"TE HAS VUELTO LOCA?"

Seq	Scene	Panel
27	887	2



Seq	Scene	Panel
27	888	1

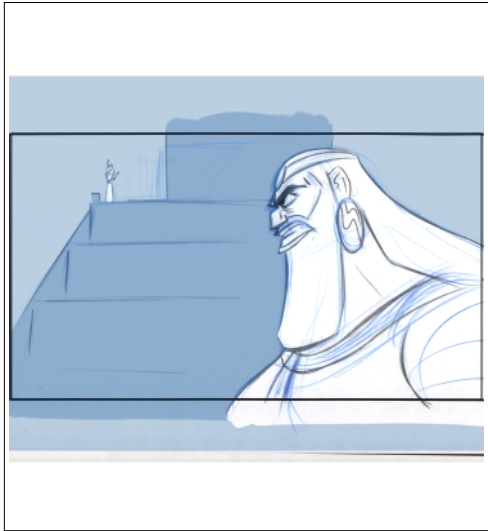

Dialog

GILGAMESH:

"MATARÉ A ESA MALDITA BESTIA! TE LO JURO POR SAMASH!"

Seq	Scene	Panel
27	888	2

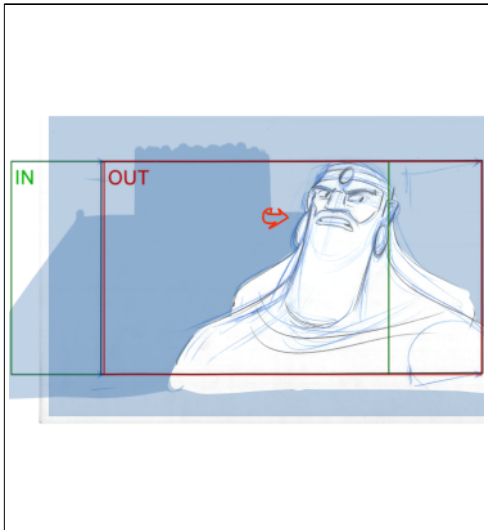

Dialog

ENKIDU EN OFF:

"GILGAMESH!"

Seq	Scene	Panel
27	889	1

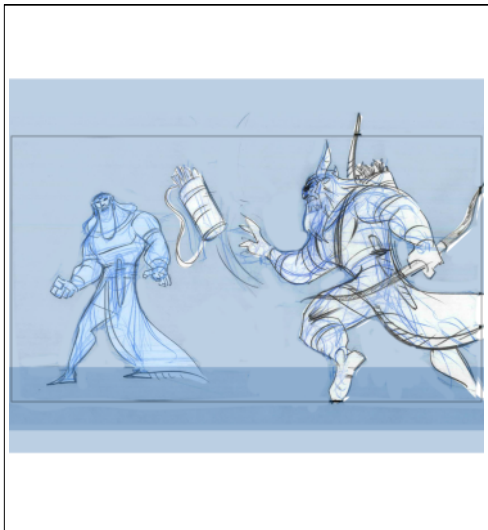

Dialog

ENKIDU:

"DETENGAMOS LA CARRERA DE DESTRUCCIÓN"

Seq	Scene	Panel
27	890	1

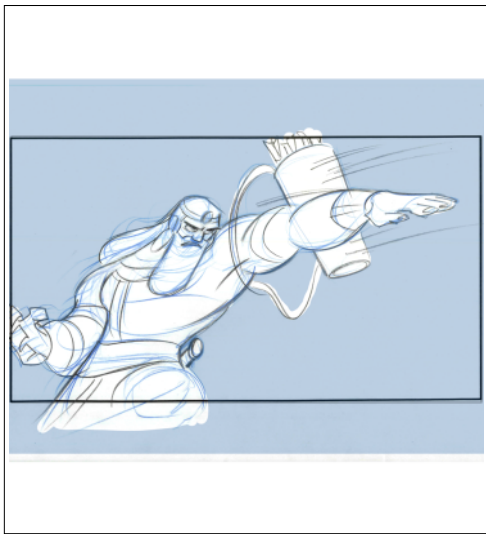

Dialog

ENKIDU EN OFF:
"DE ESTA FIERA ABOMINABLE!"

Seq	Scene	Panel
27	890	2

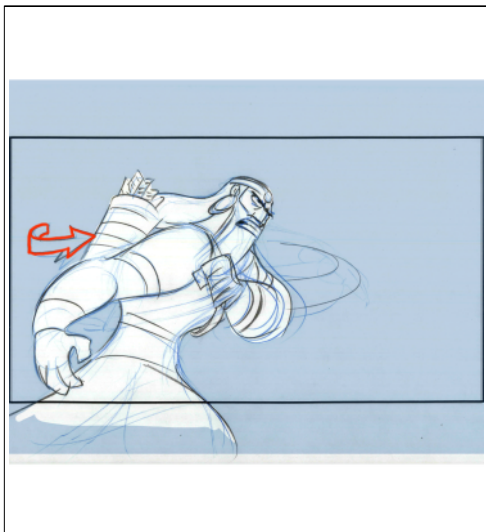

Seq	Scene	Panel
27	890	3



Seq	Scene	Panel
27	890	4

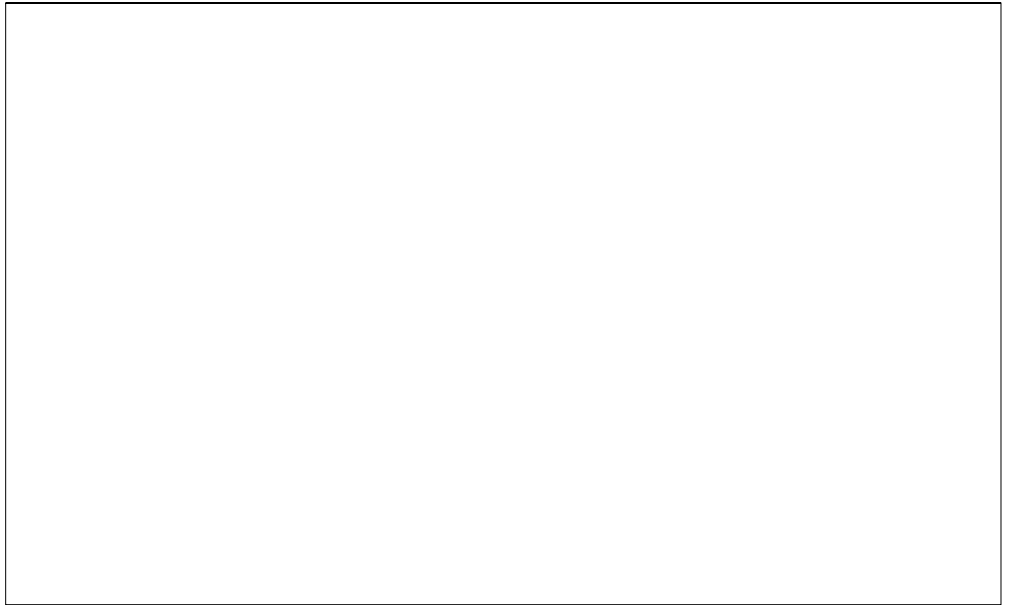

Seq	Scene	Panel
27	891	1

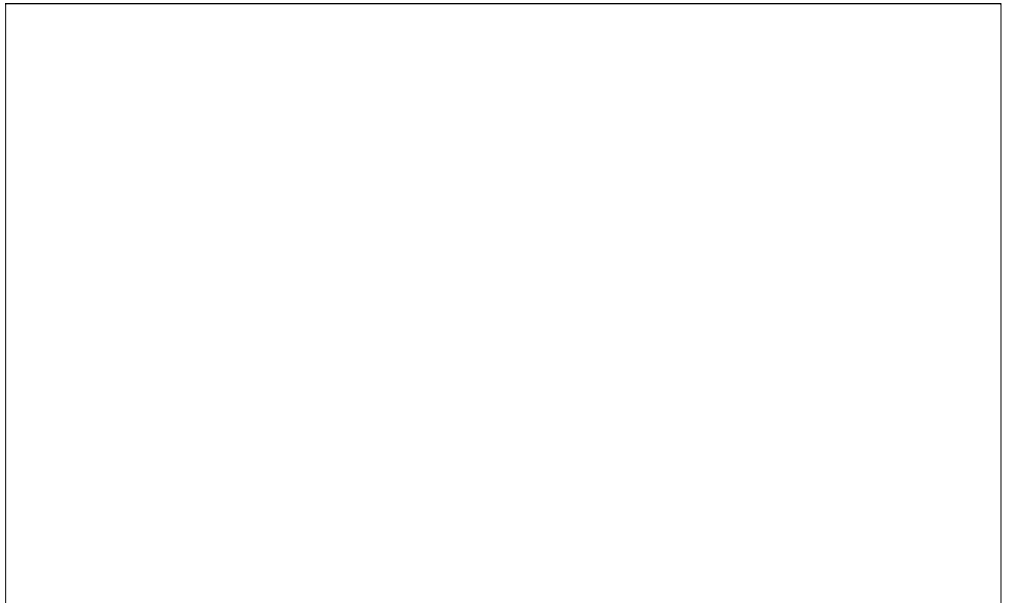
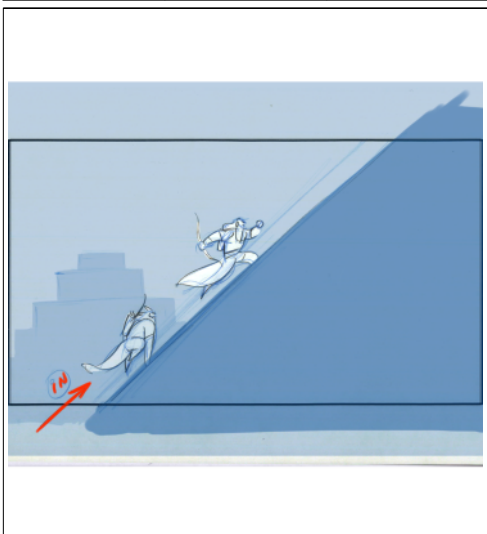

Seq	Scene	Panel
27	892	1

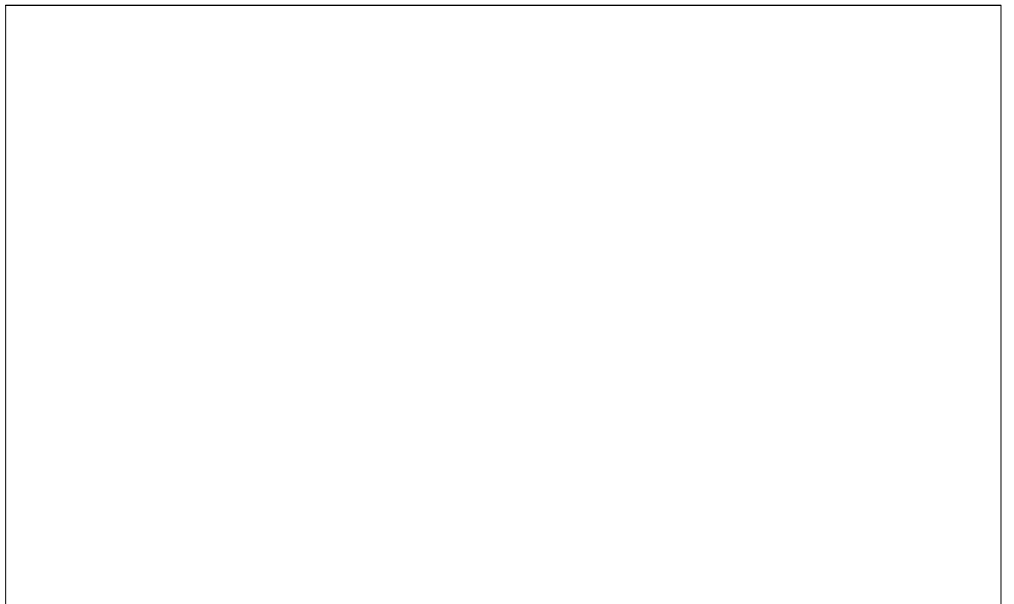
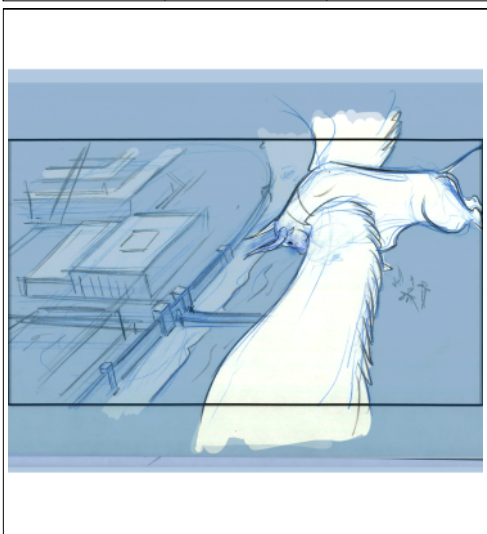

Seq	Scene	Panel
27	892	2

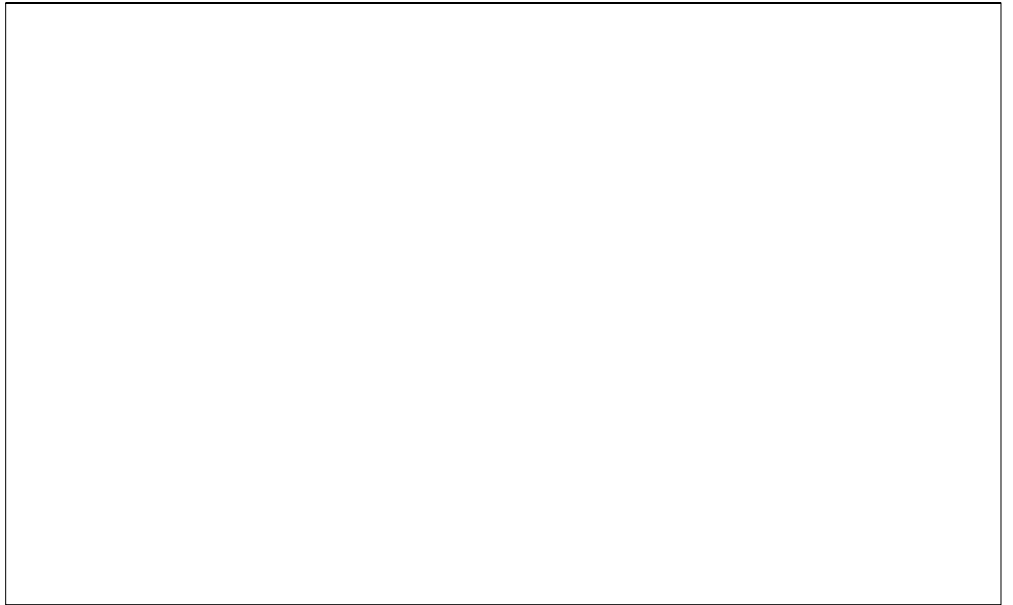

Seq	Scene	Panel
27	892	3

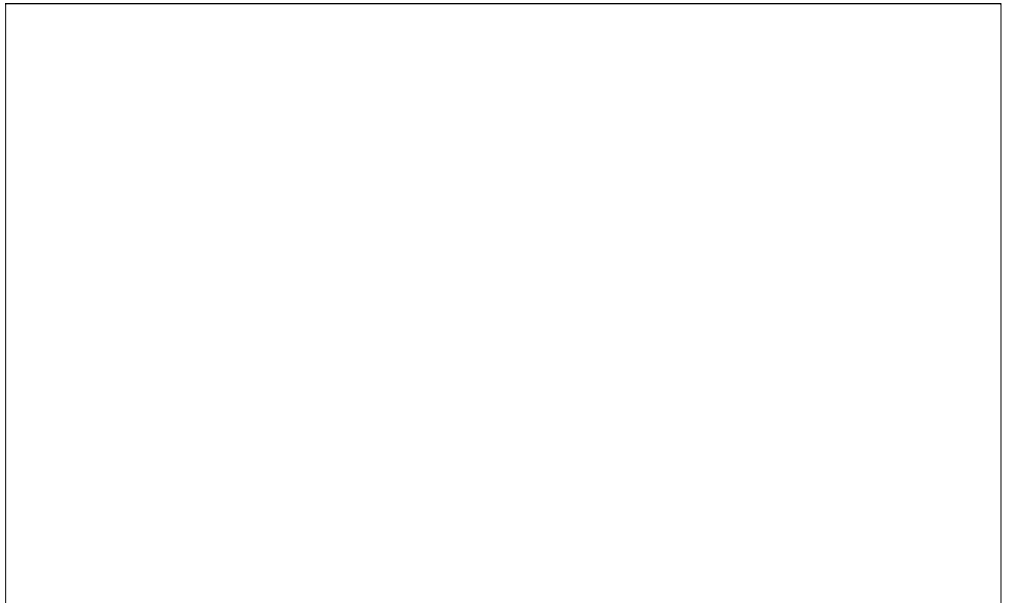
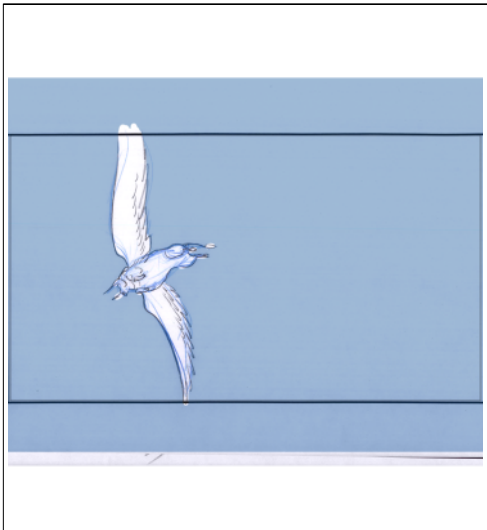

Seq	Scene	Panel
27	893	1

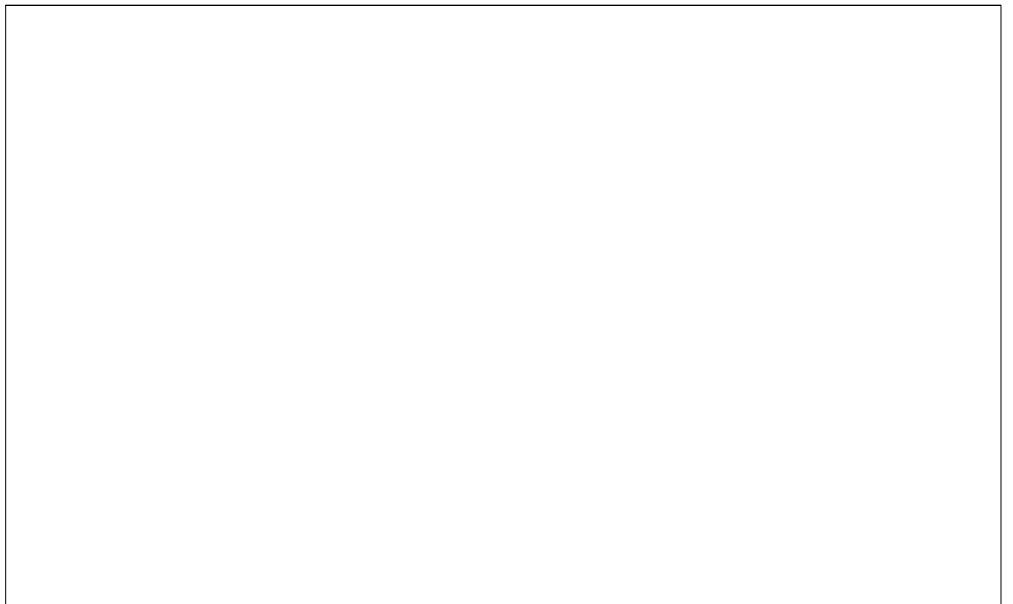

Seq	Scene	Panel
27	894	1

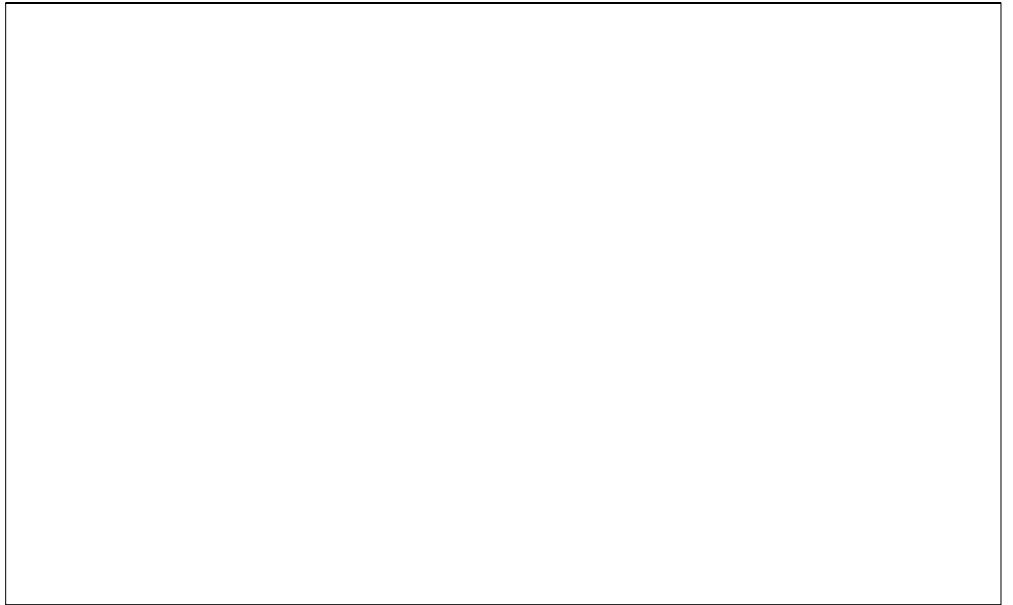
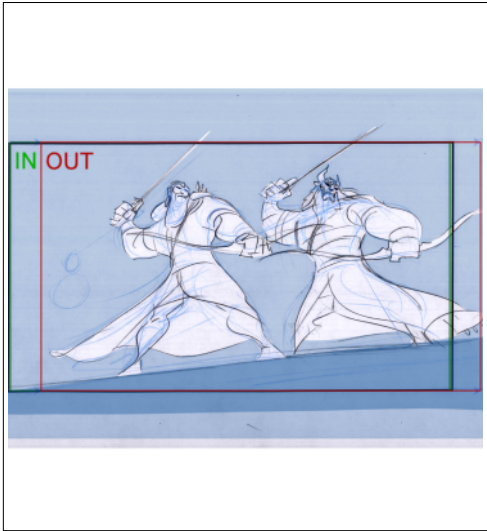

Seq	Scene	Panel
27	894	2

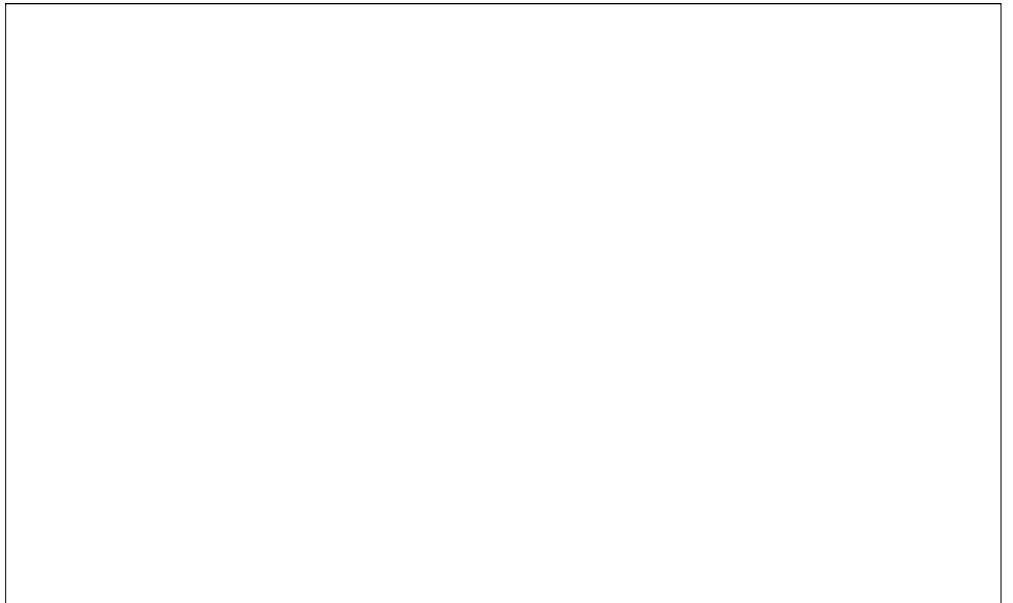
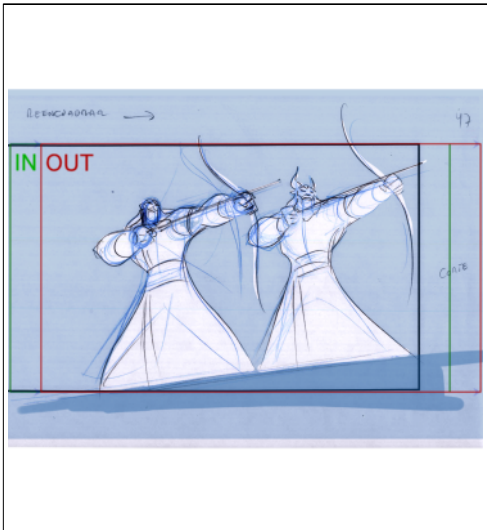

Seq	Scene	Panel
27	895	1

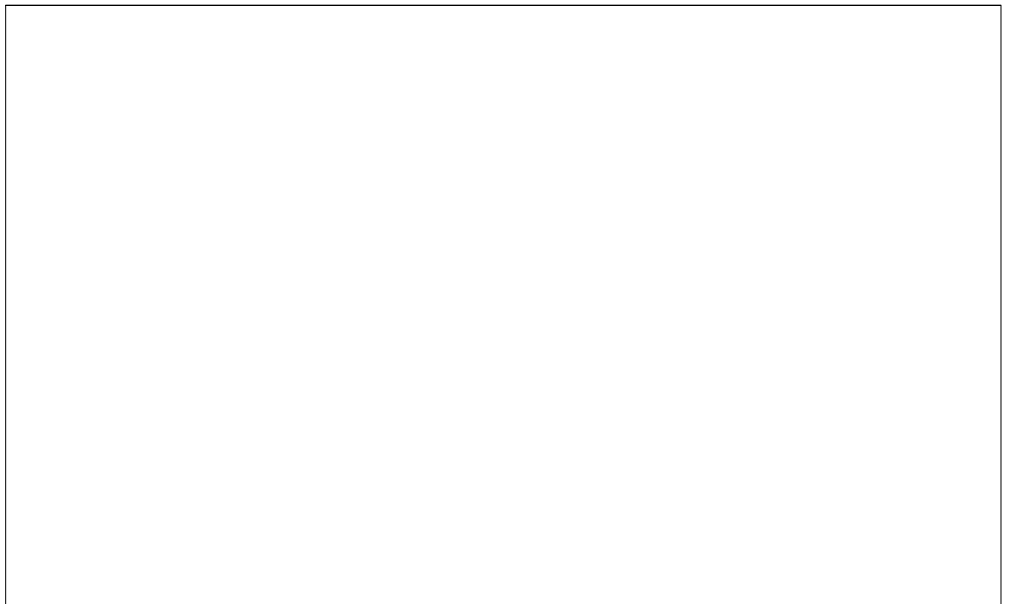
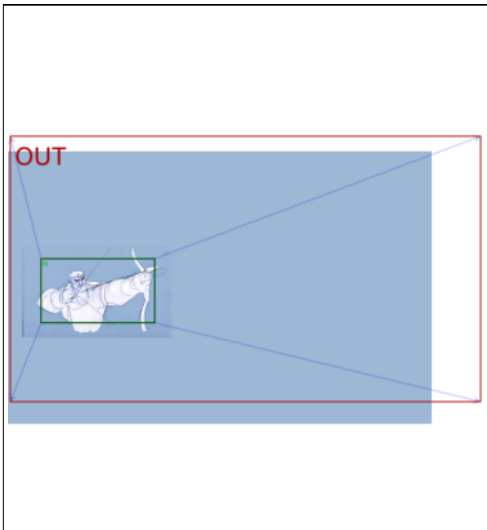

Seq	Scene	Panel
27	895	2

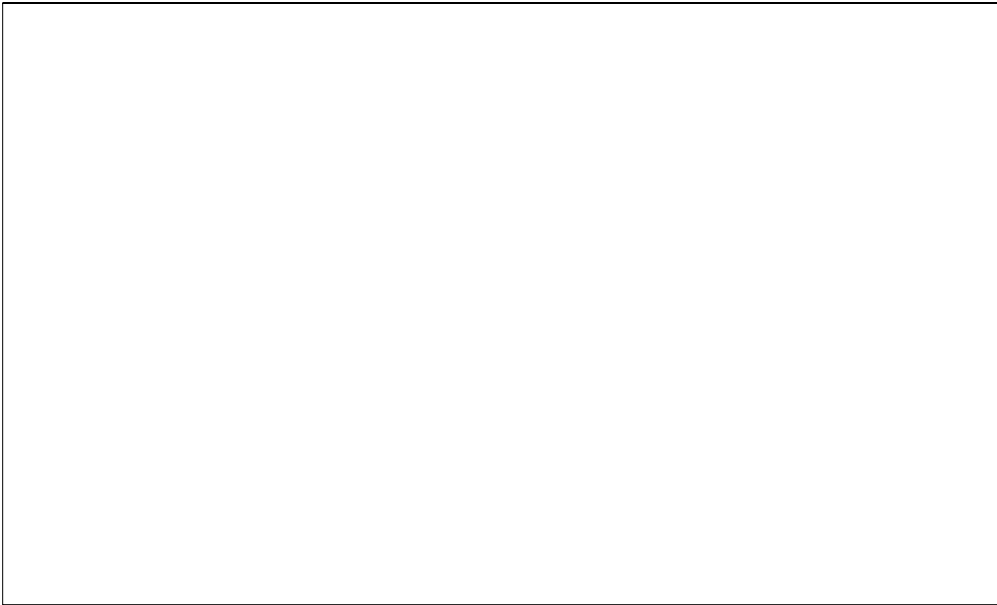
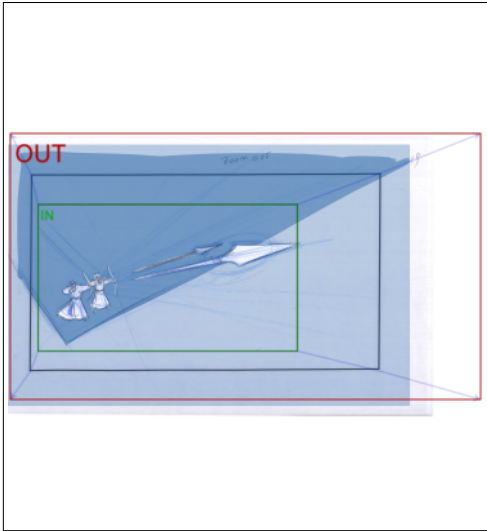

Seq	Scene	Panel
27	895	3

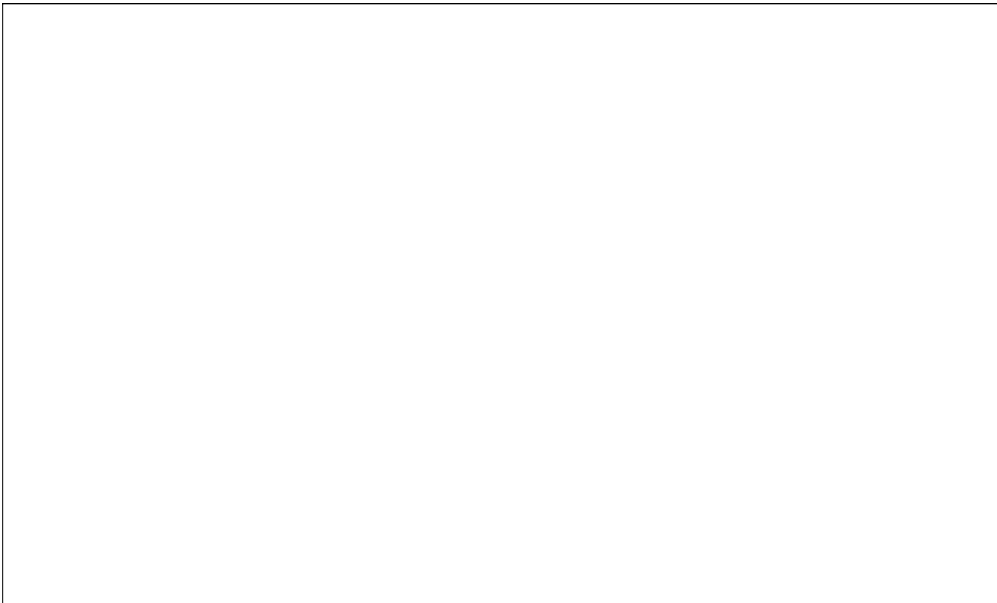
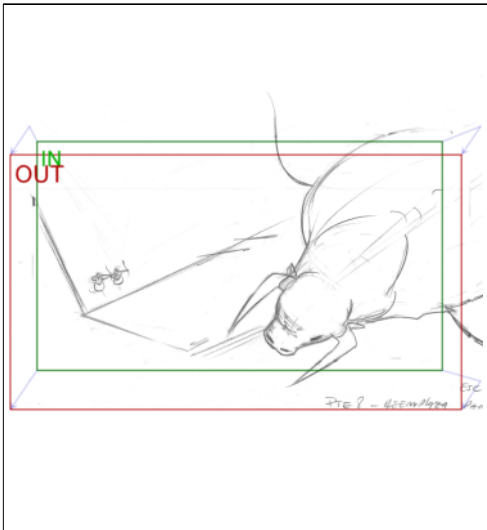

Seq	Scene	Panel
27	896	1

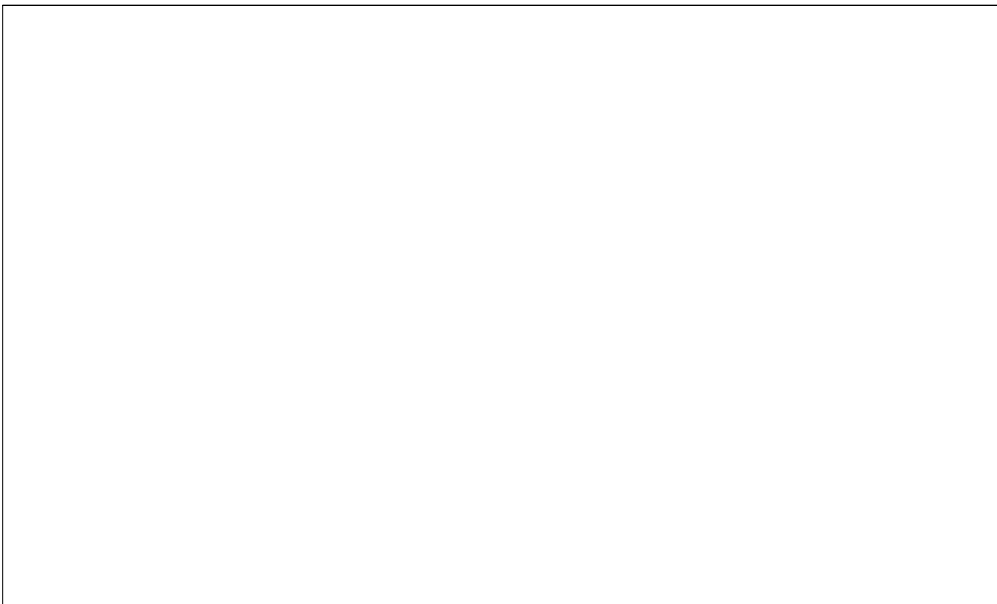
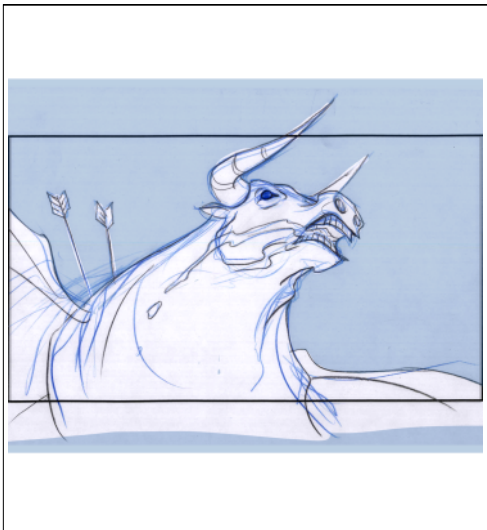

Seq	Scene	Panel
27	897	1

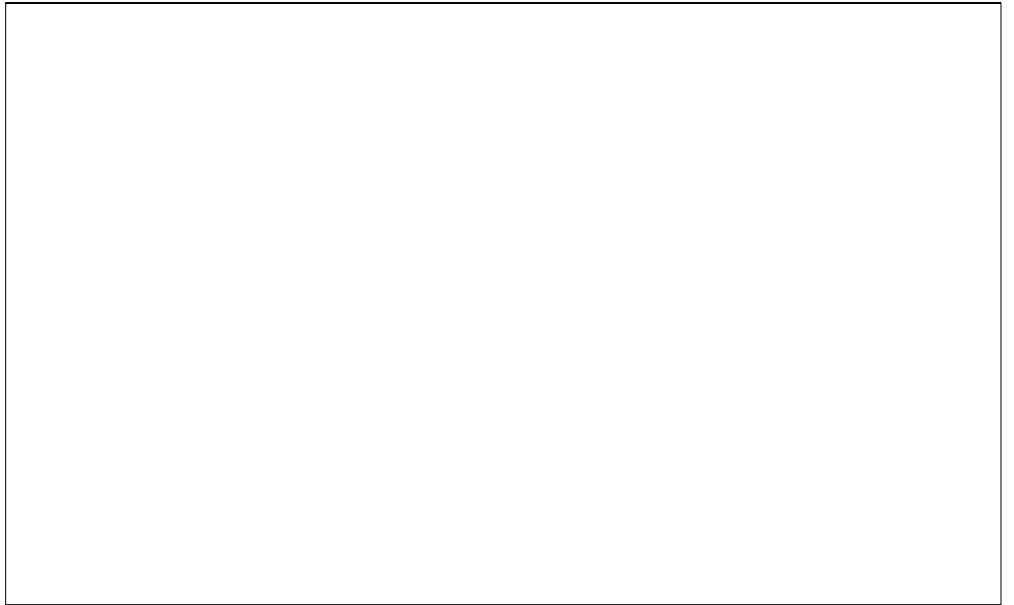
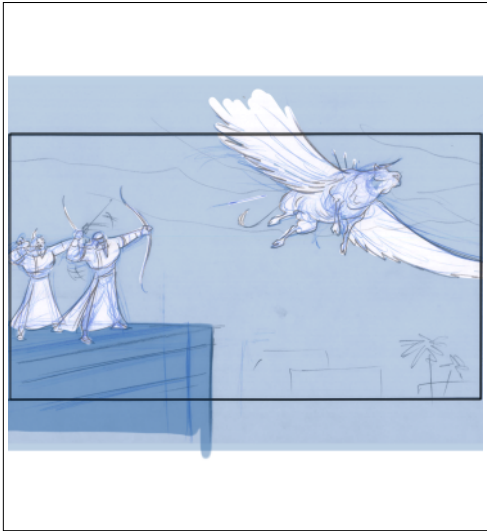

Seq	Scene	Panel
27	897	2

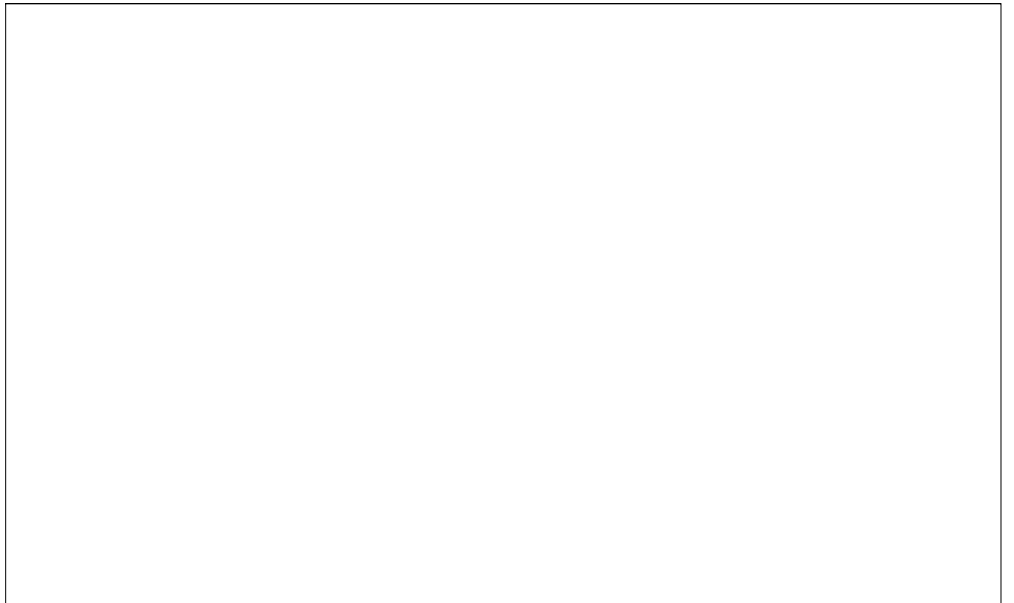
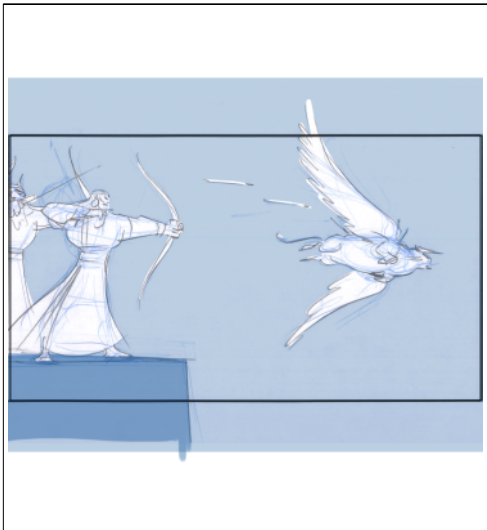

Seq	Scene	Panel
27	897	3

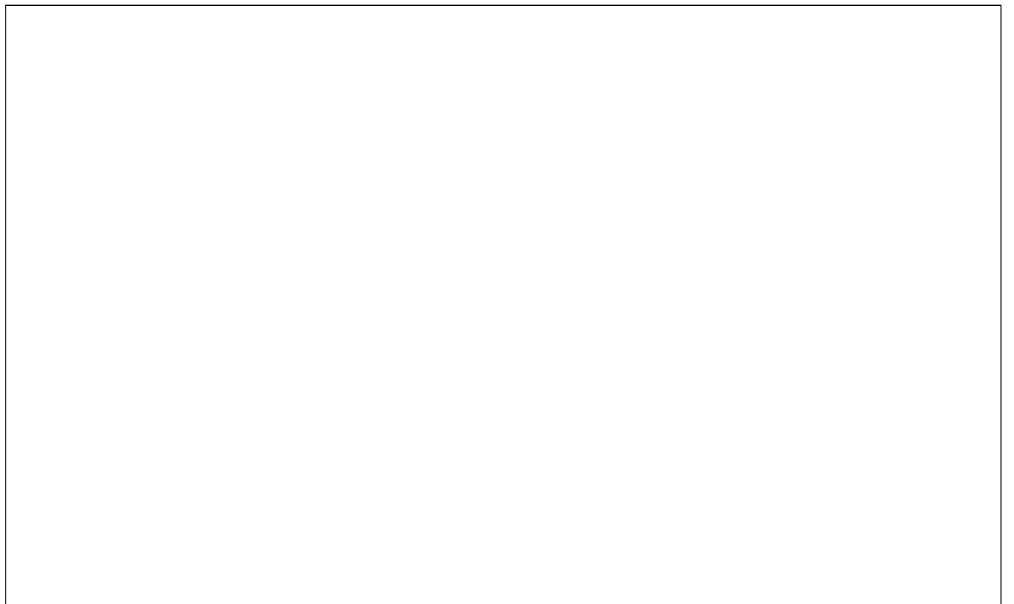
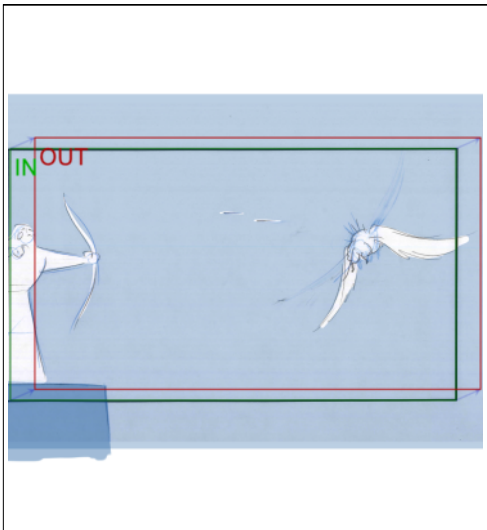

Seq	Scene	Panel
27	897	4

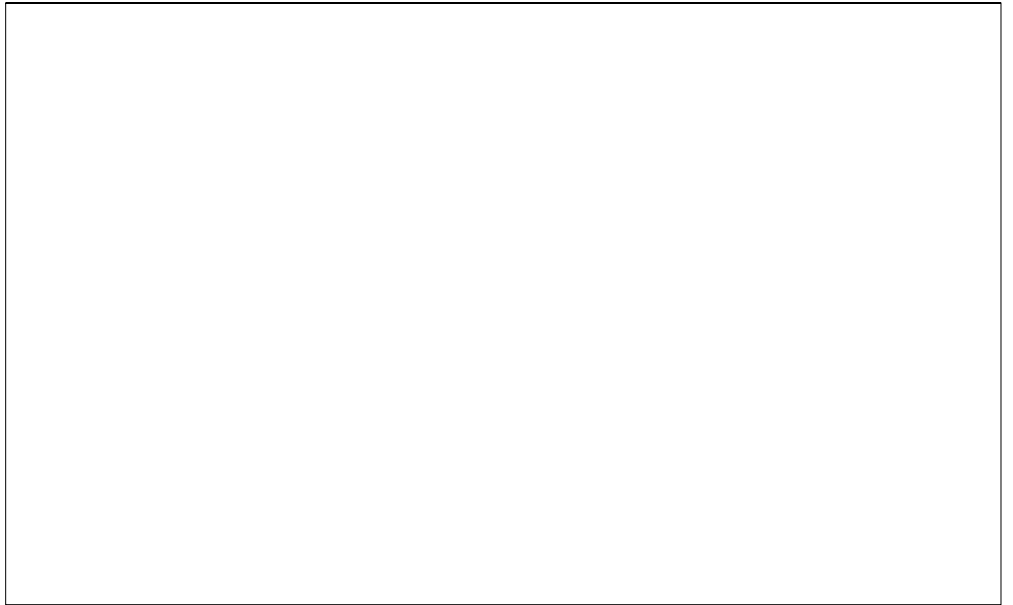
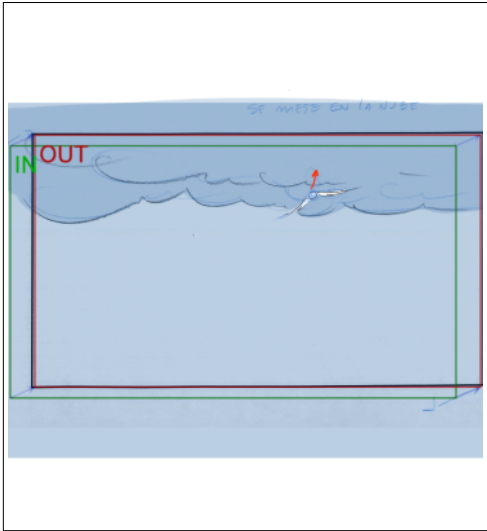

Seq	Scene	Panel
27	898	1

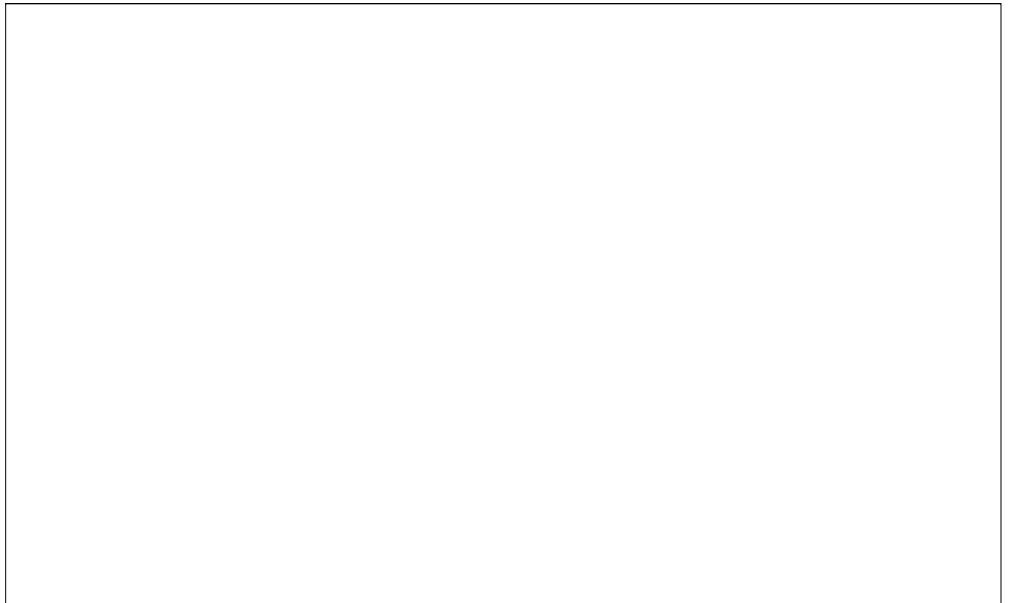
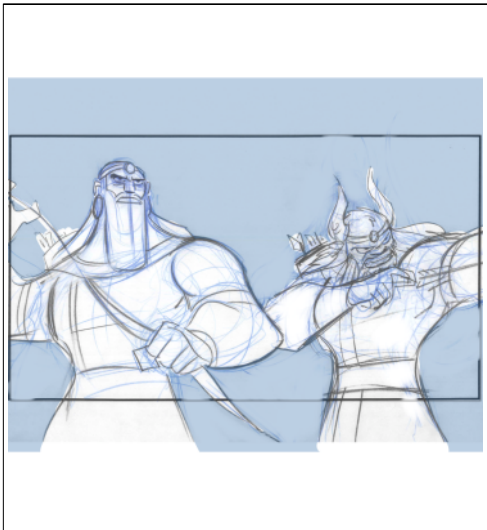

Seq	Scene	Panel
27	899	1

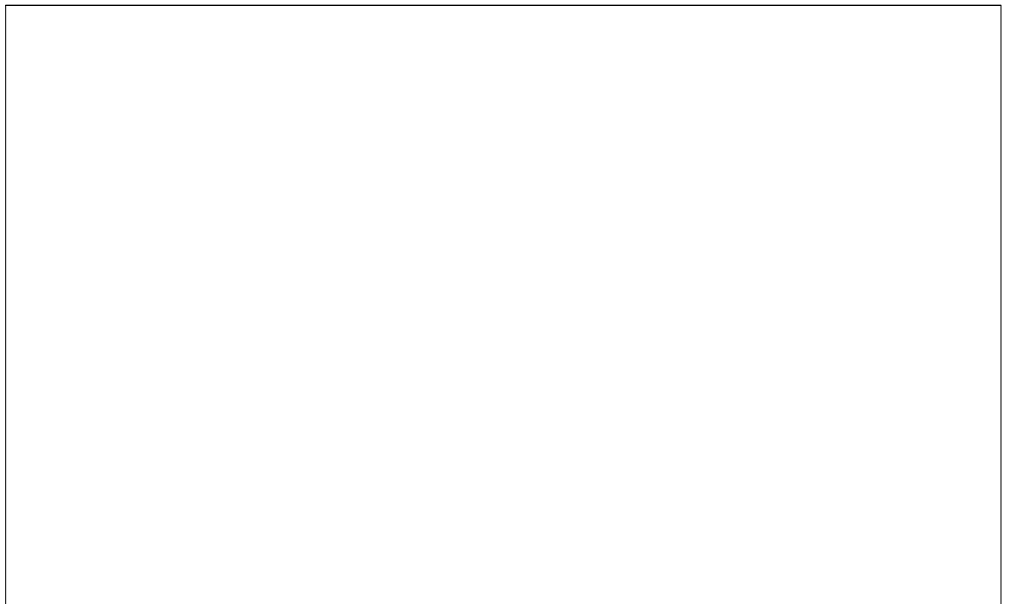
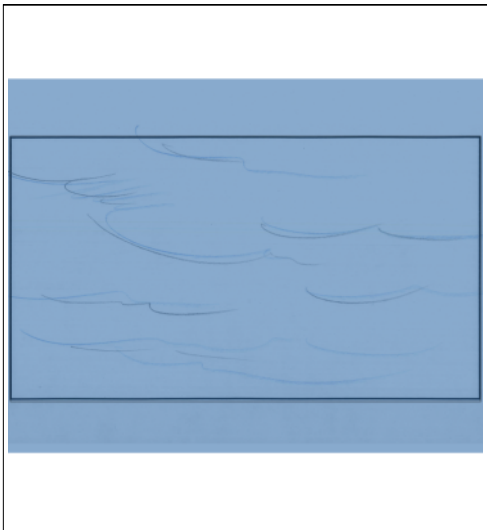

Seq	Scene	Panel
27	899	2

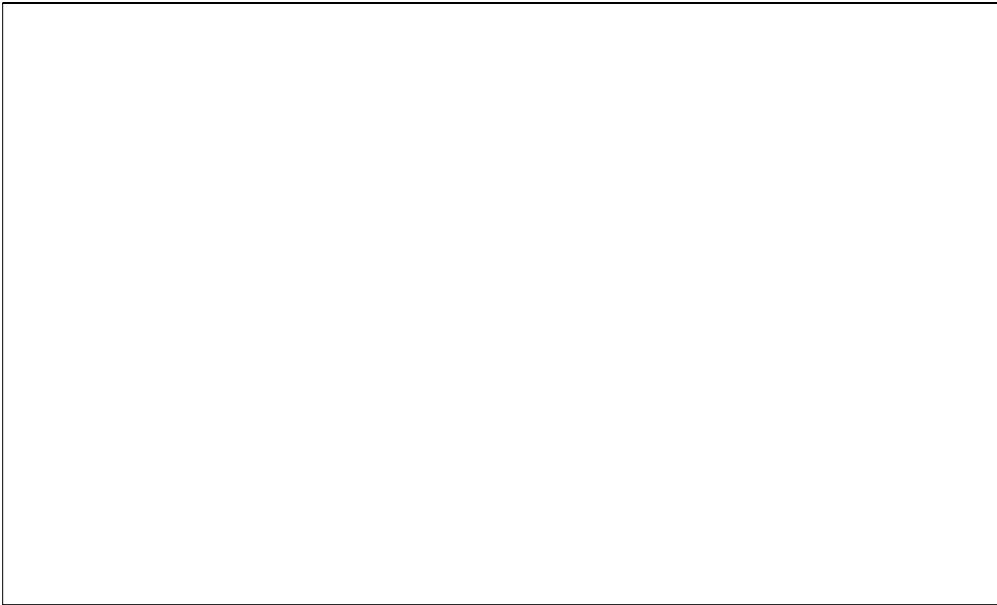
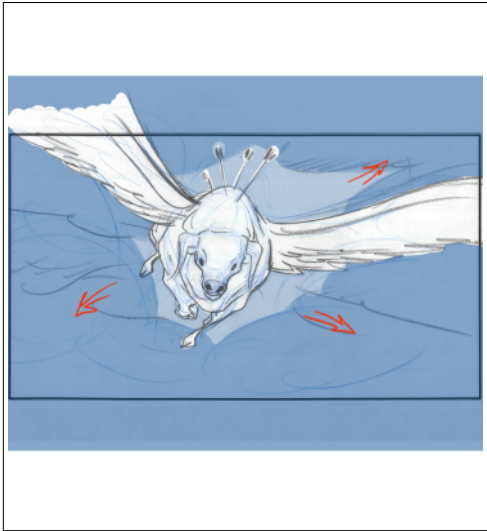

Seq	Scene	Panel
27	899	3

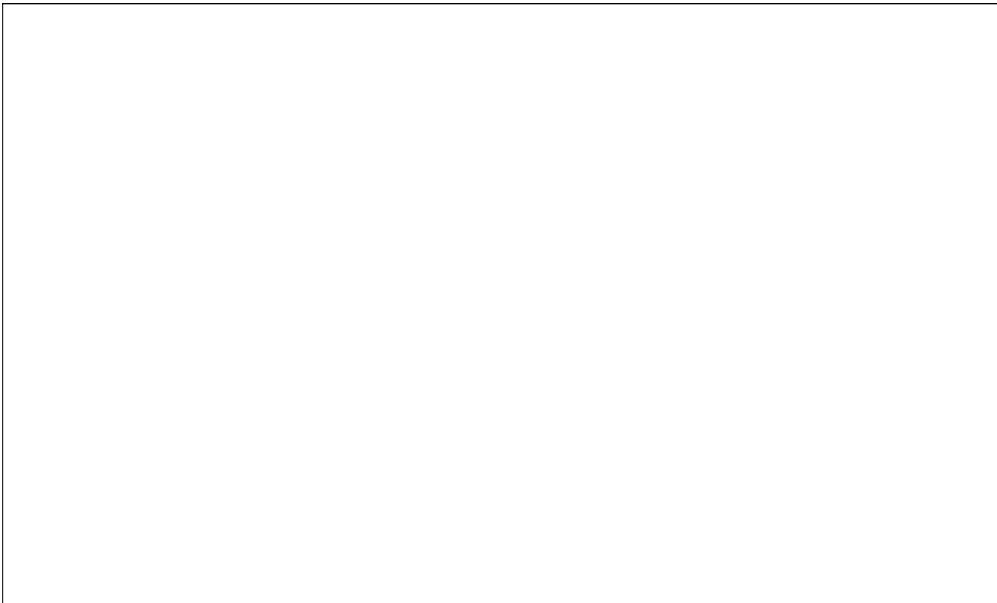
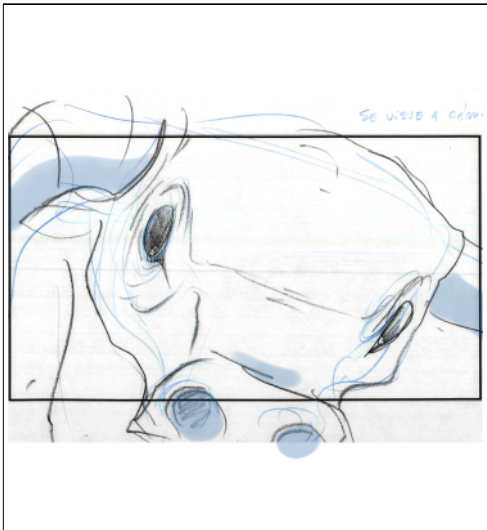

Seq	Scene	Panel
27	900	1

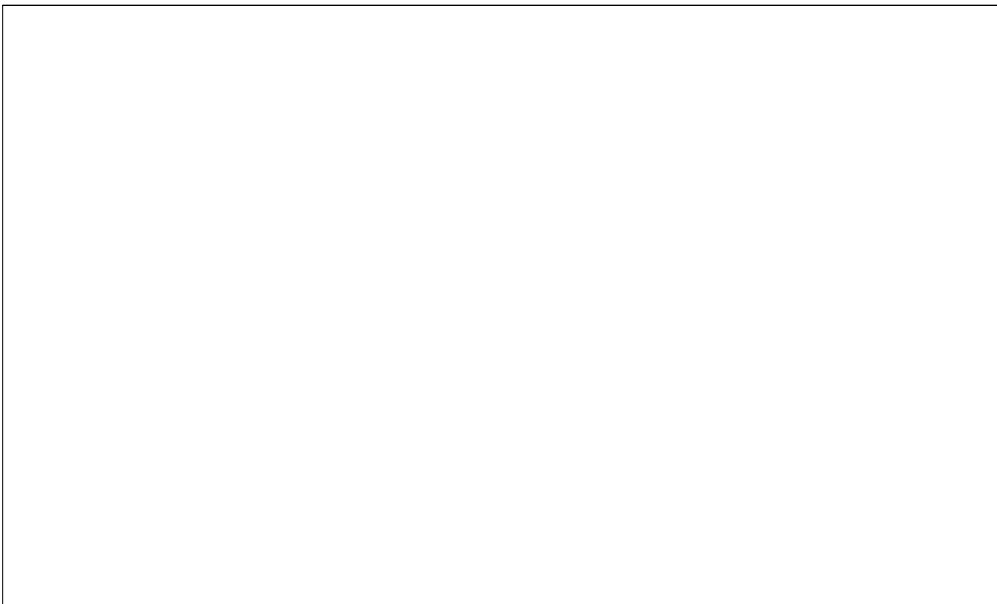
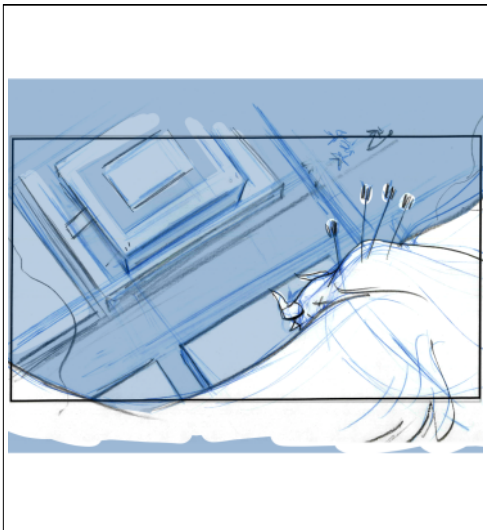

Seq	Scene	Panel
27	900	2

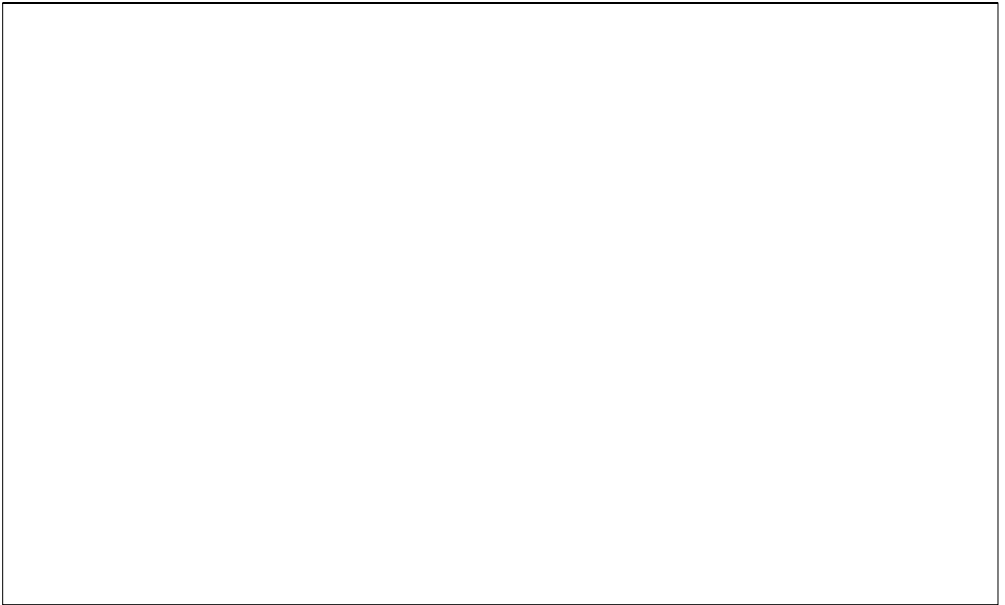
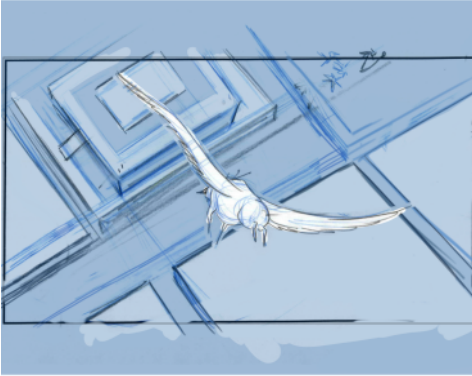

Seq	Scene	Panel
27	901	1

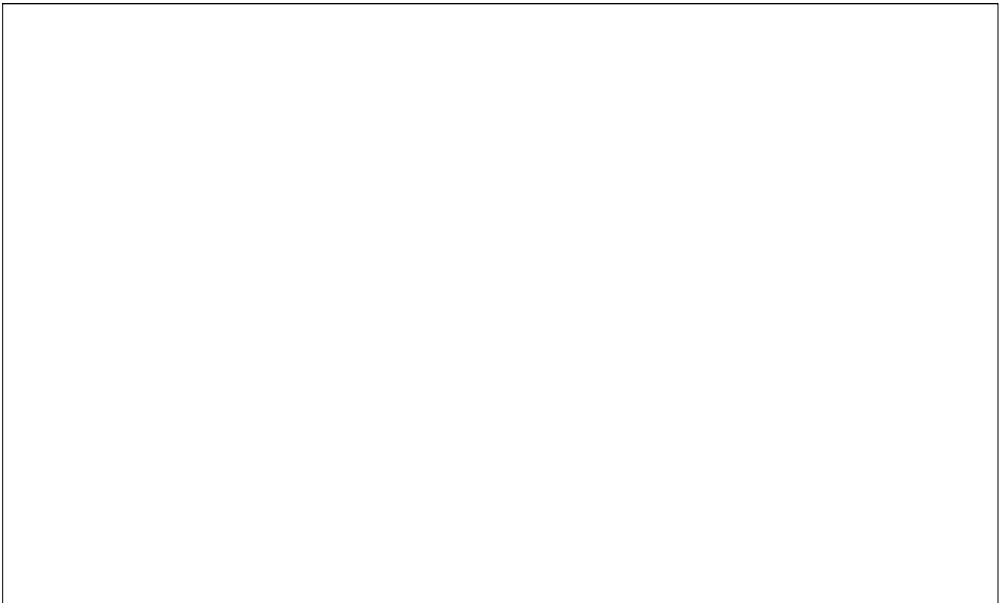
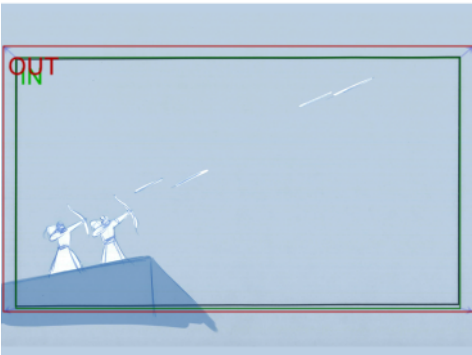

Seq	Scene	Panel
27	901	2

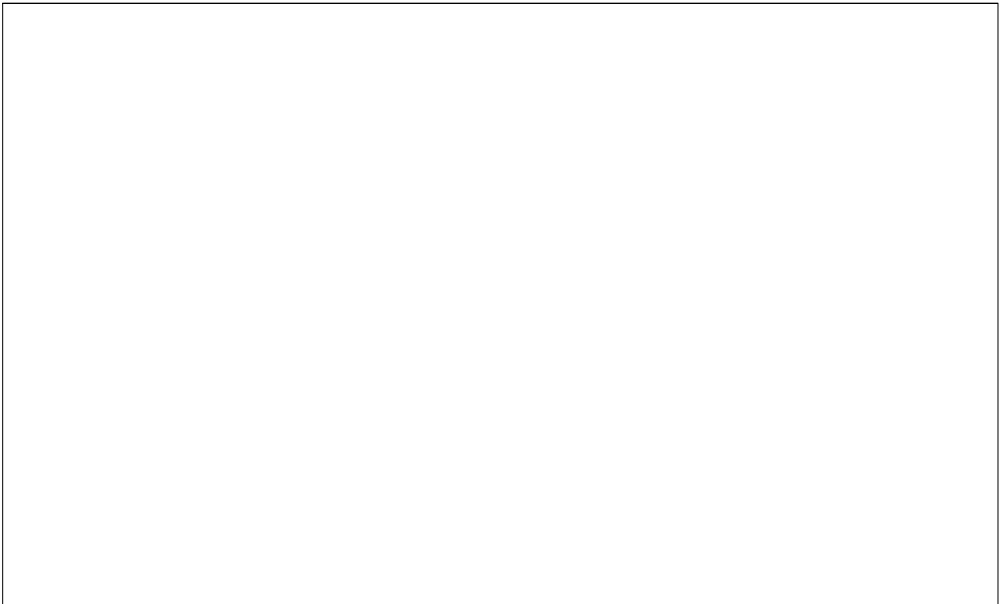
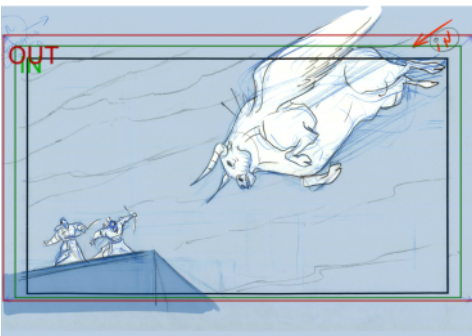

Seq	Scene	Panel
27	901	3

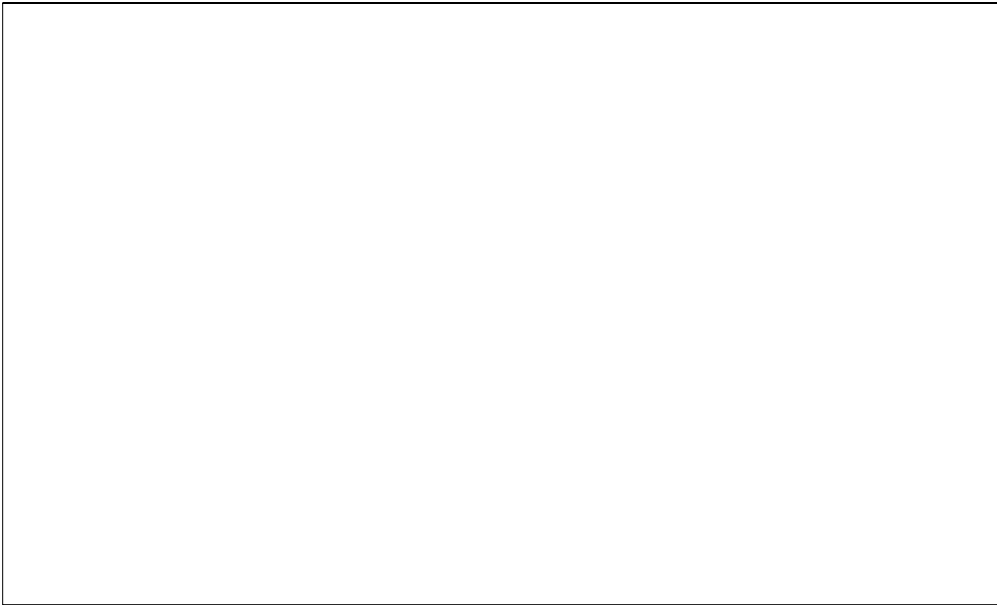
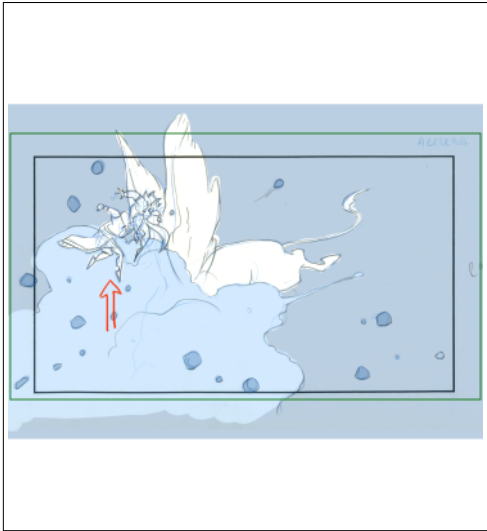

Seq	Scene	Panel
27	902	1

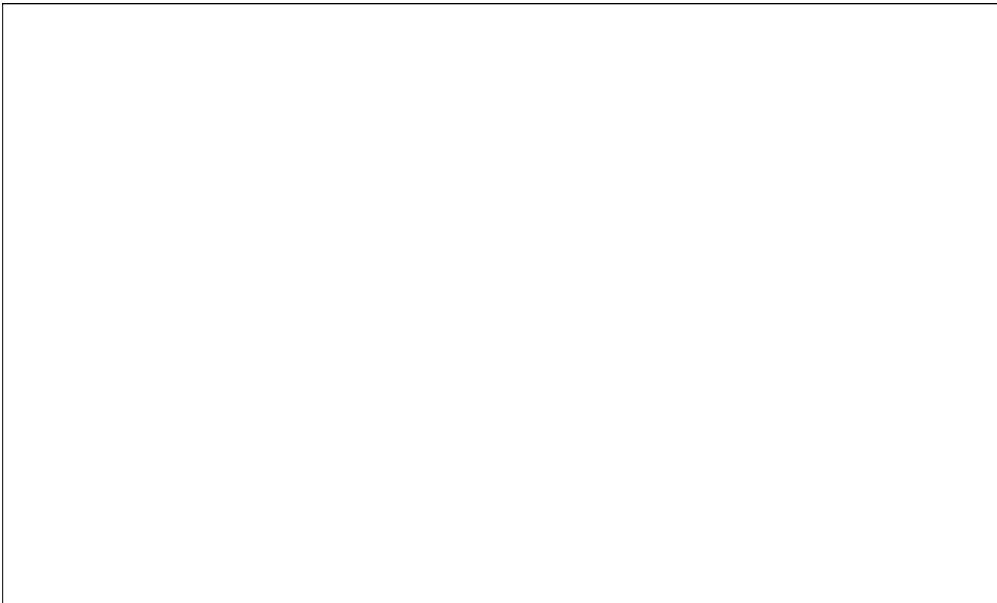
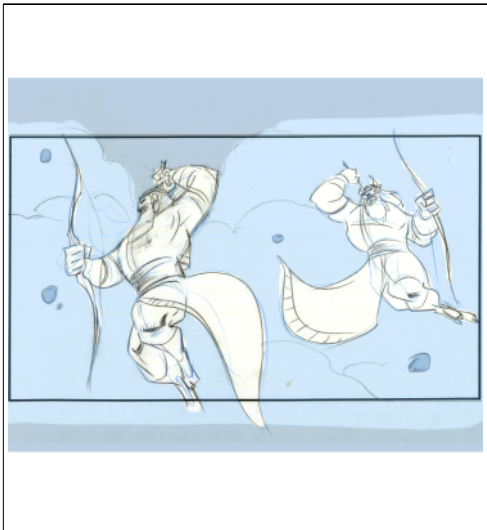

Seq	Scene	Panel
27	902	2

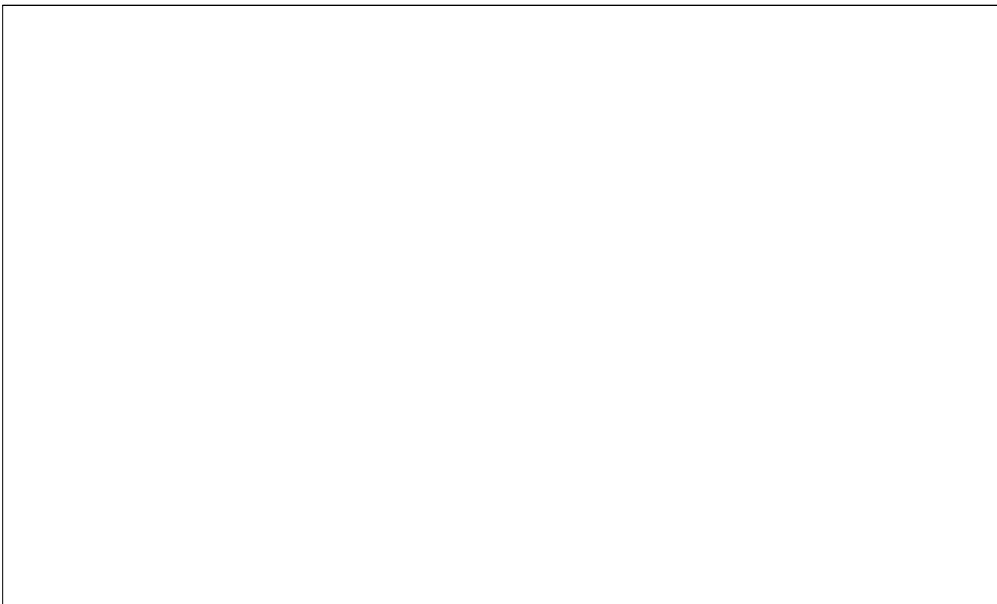
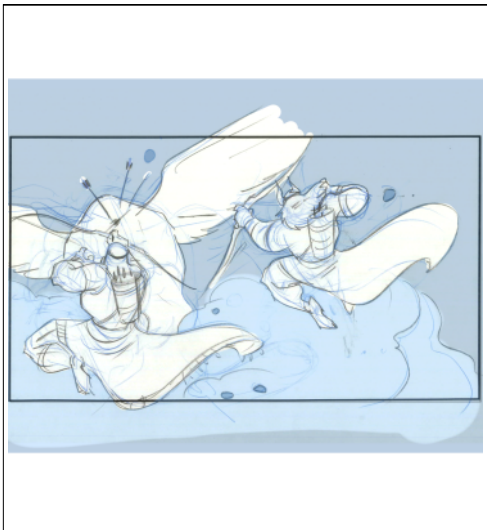

Seq	Scene	Panel
27	903	1

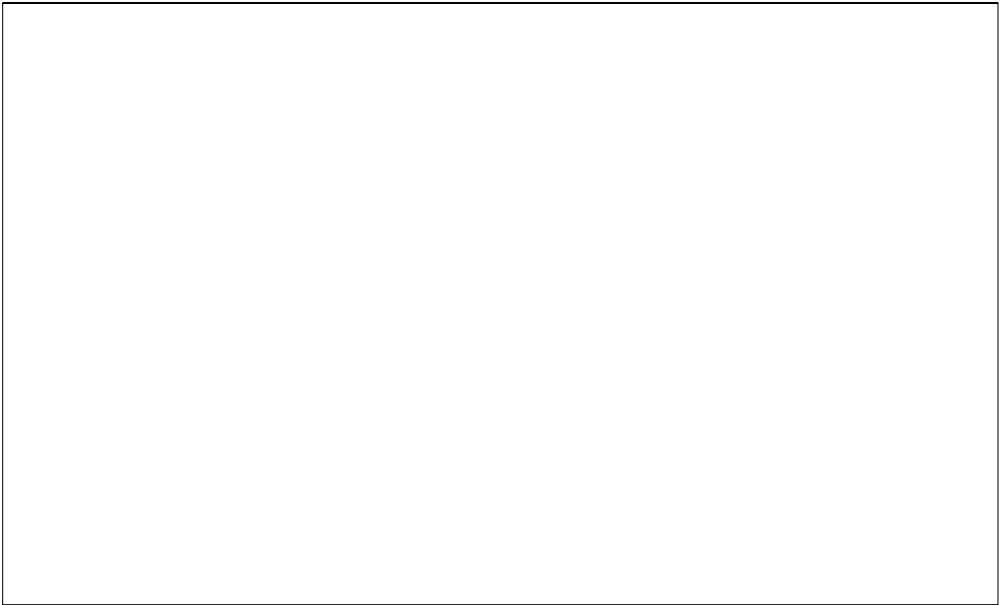
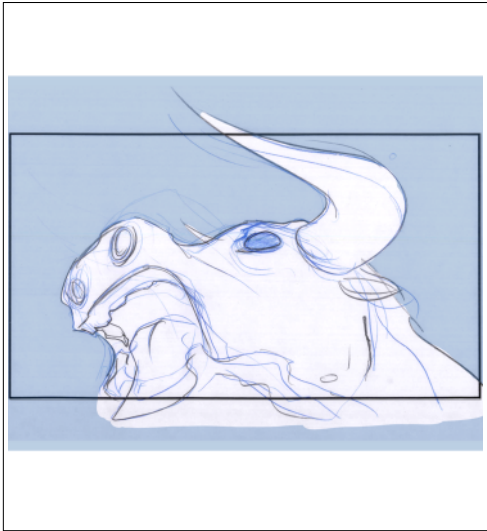

Seq	Scene	Panel
27	904	1

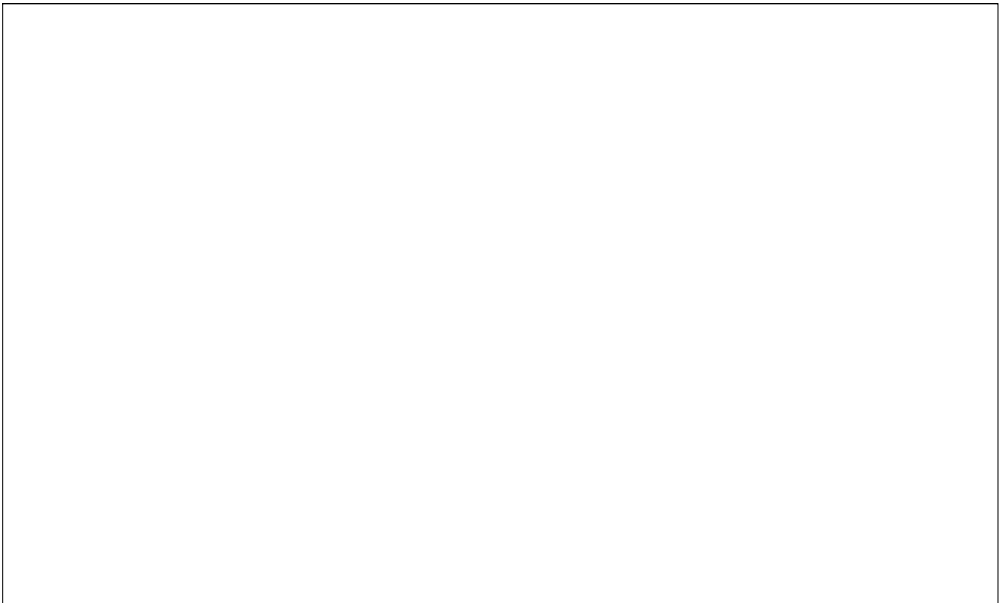
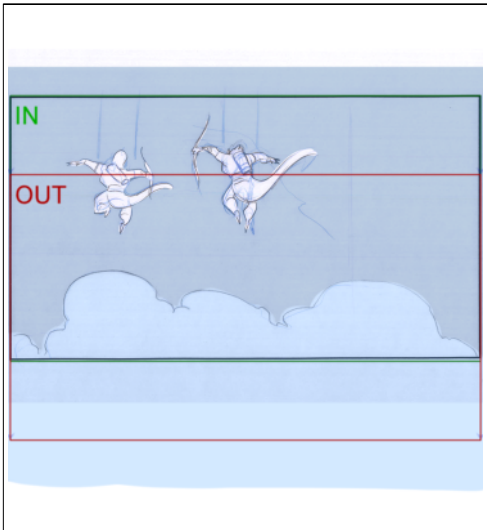

Seq	Scene	Panel
27	904	2

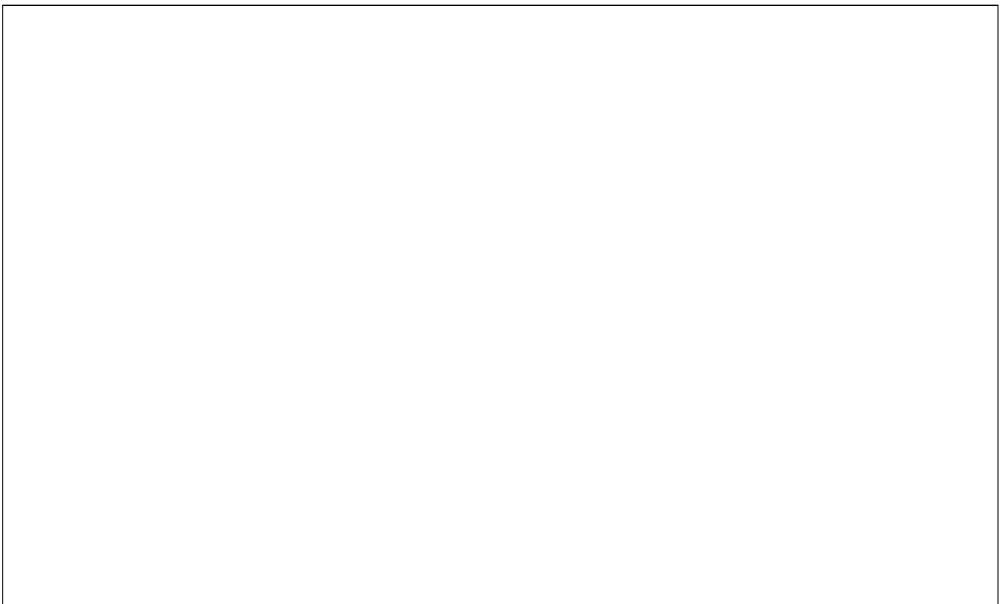
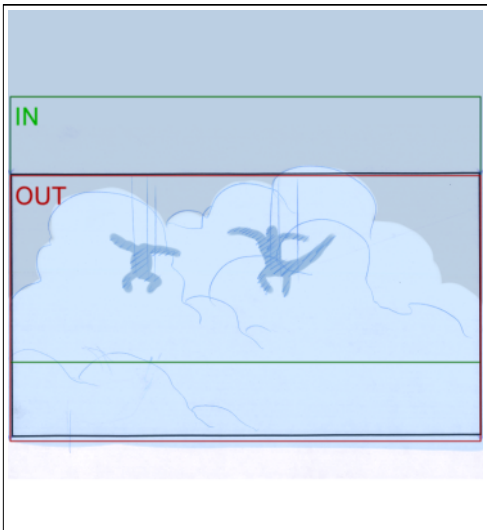

Seq	Scene	Panel
27	904	3

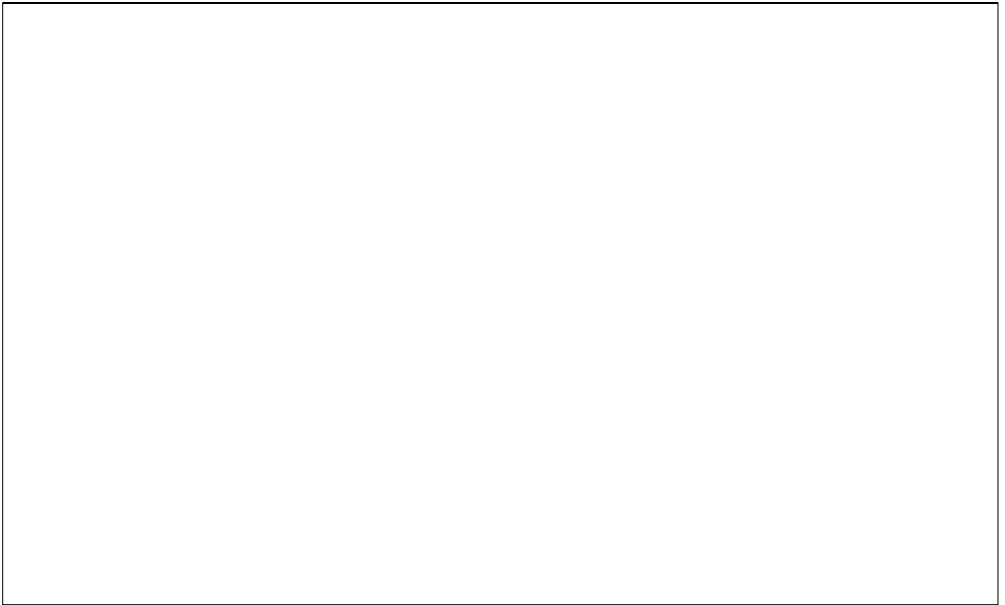
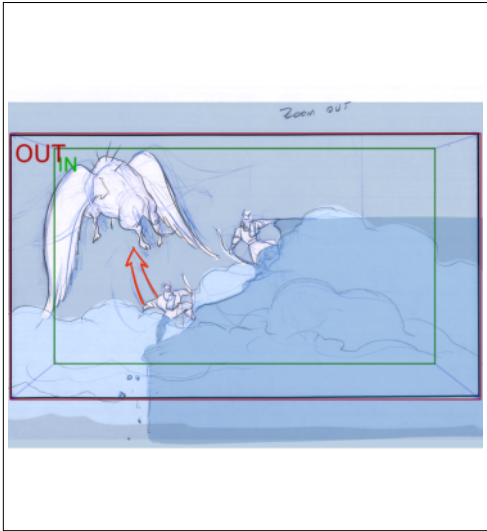

Seq	Scene	Panel
27	905	1

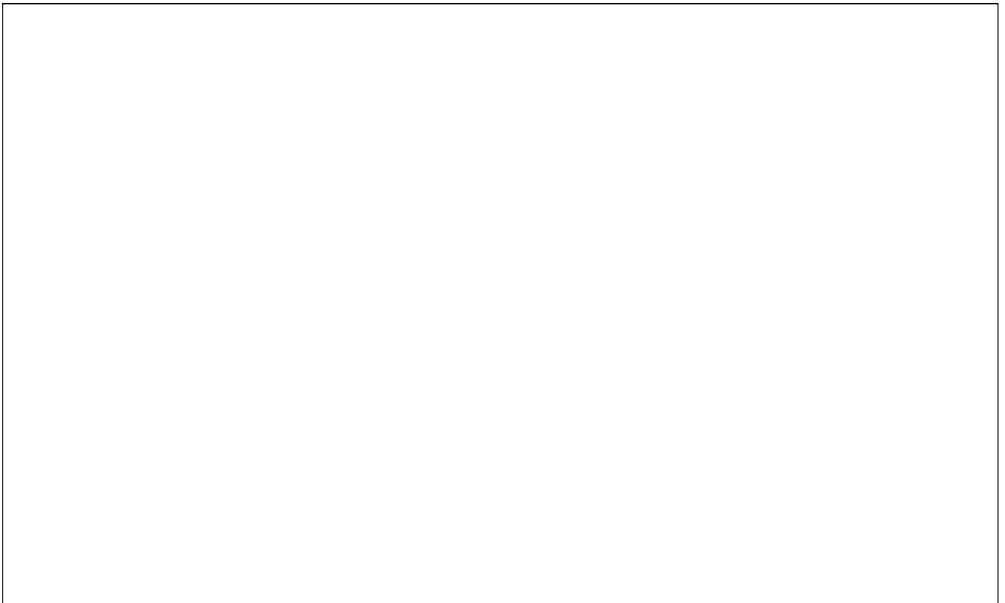
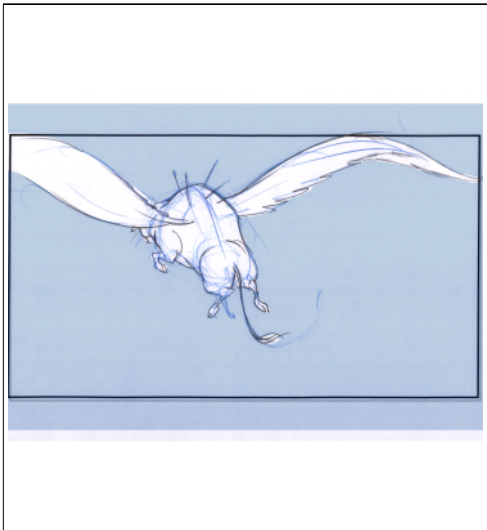

Seq	Scene	Panel
27	905	2

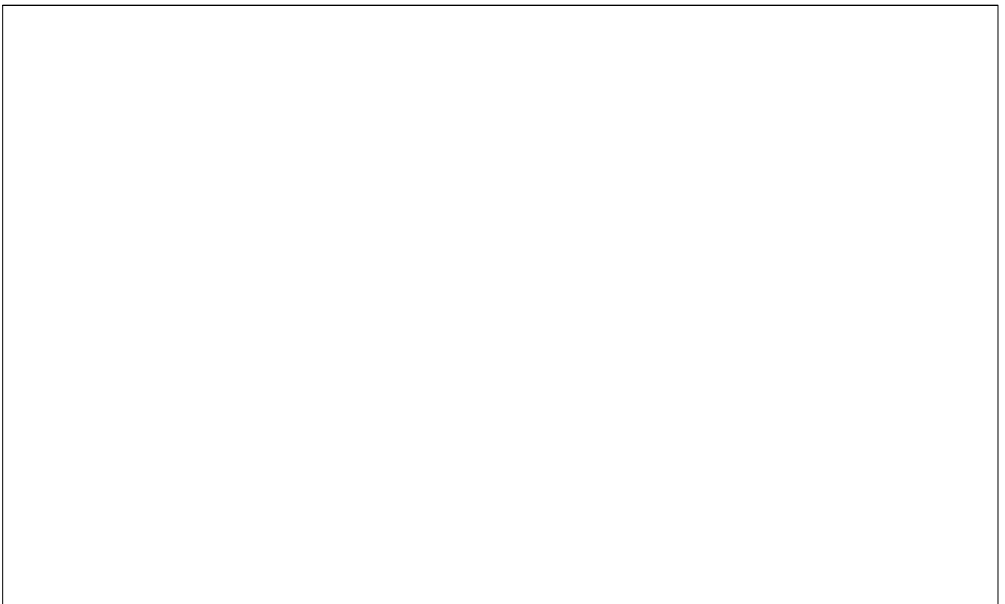
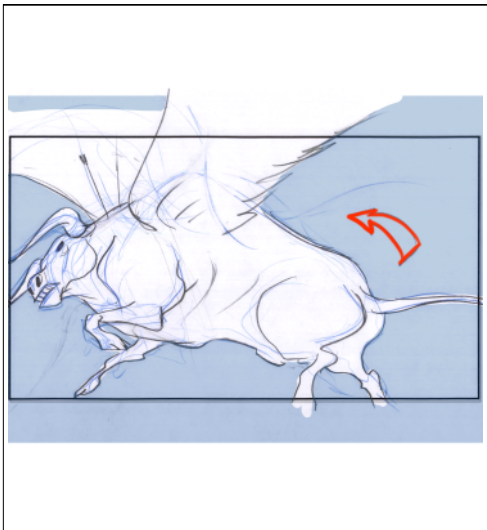

Seq	Scene	Panel
27	905	3

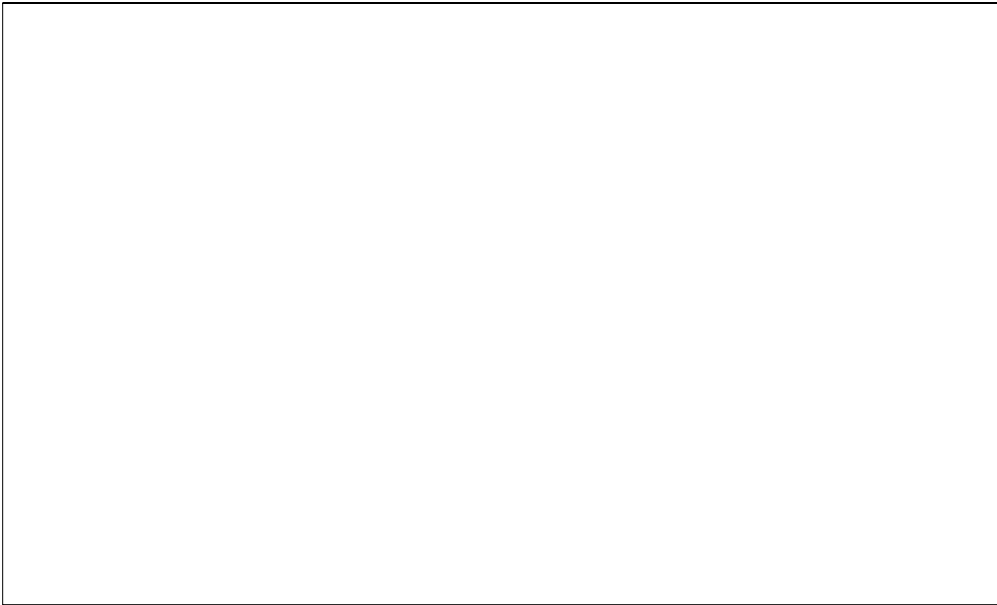
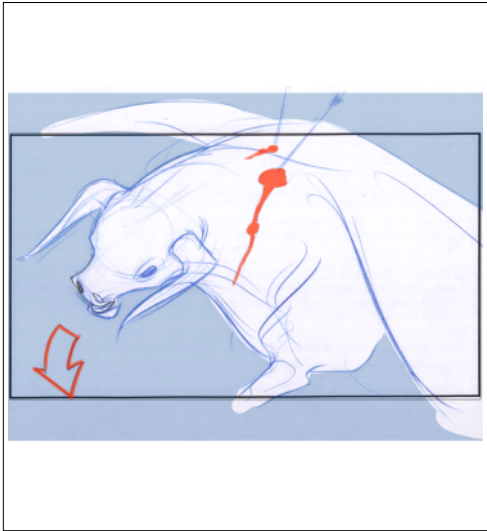

Seq	Scene	Panel
27	905	4

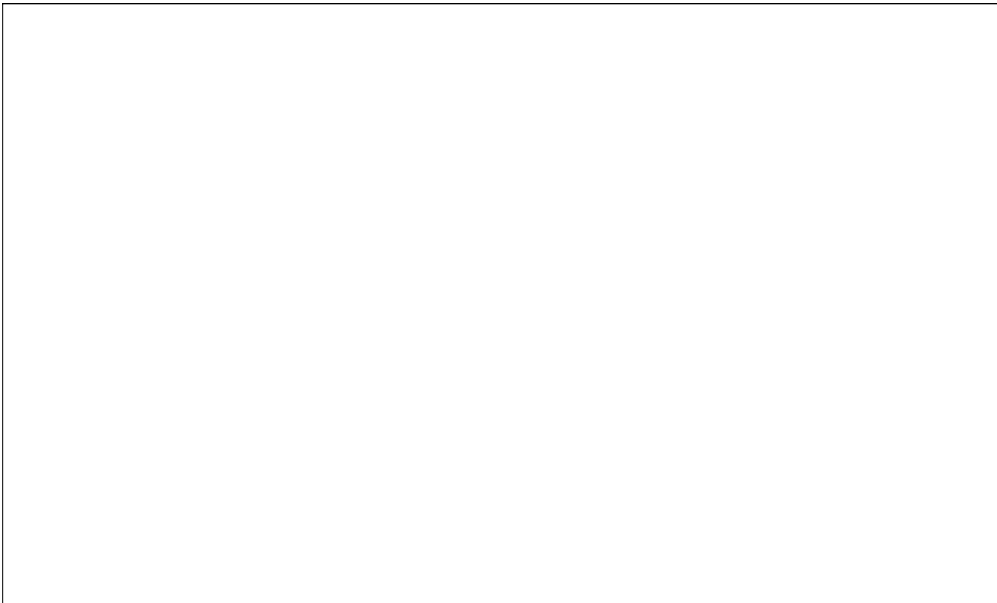
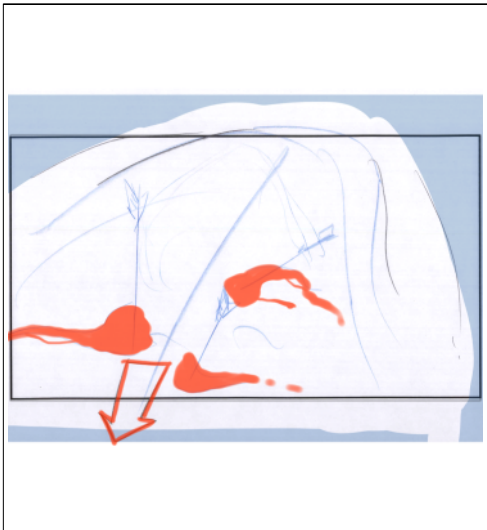

Seq	Scene	Panel
27	906	1

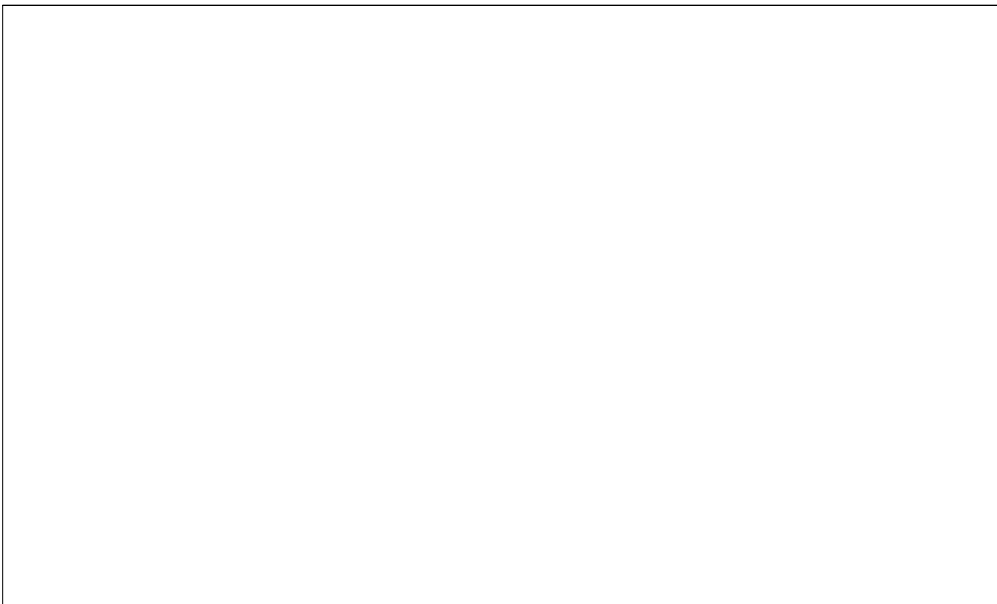
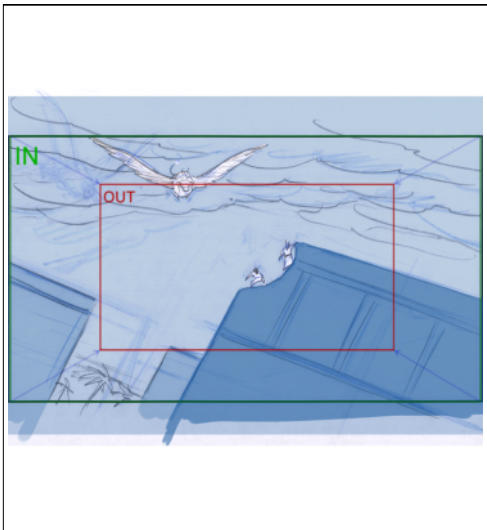

Seq	Scene	Panel
27	906	2

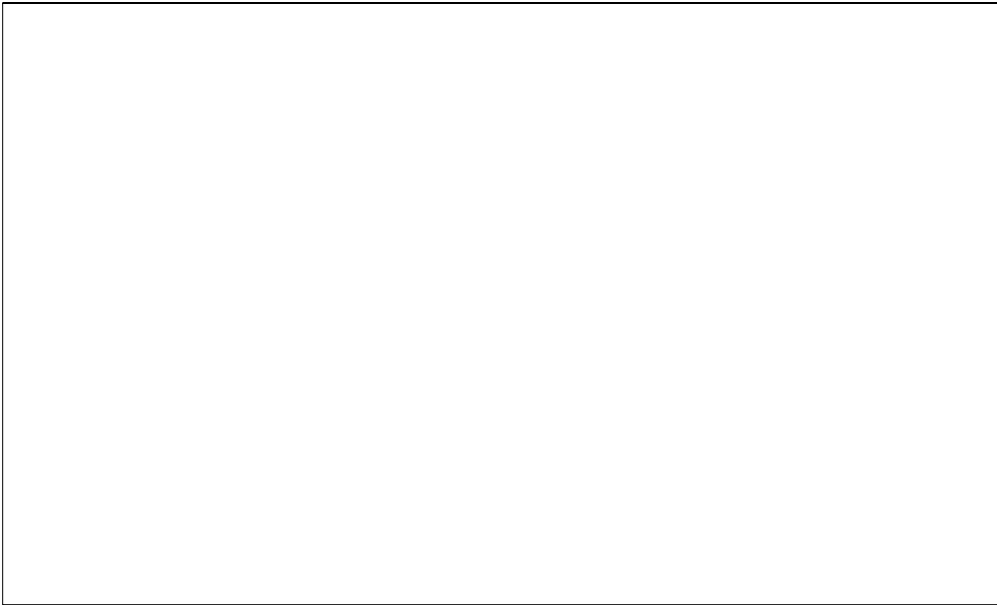
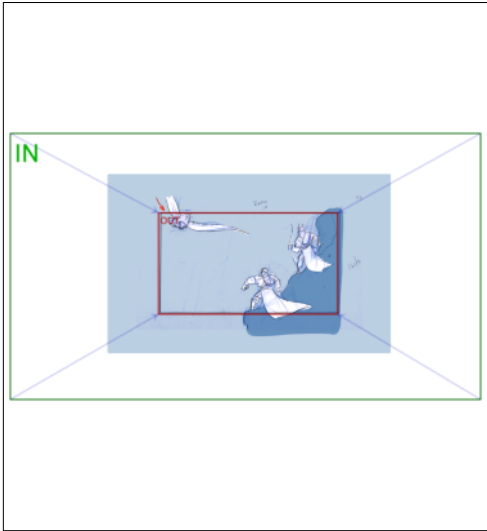

Seq	Scene	Panel
27	907	1

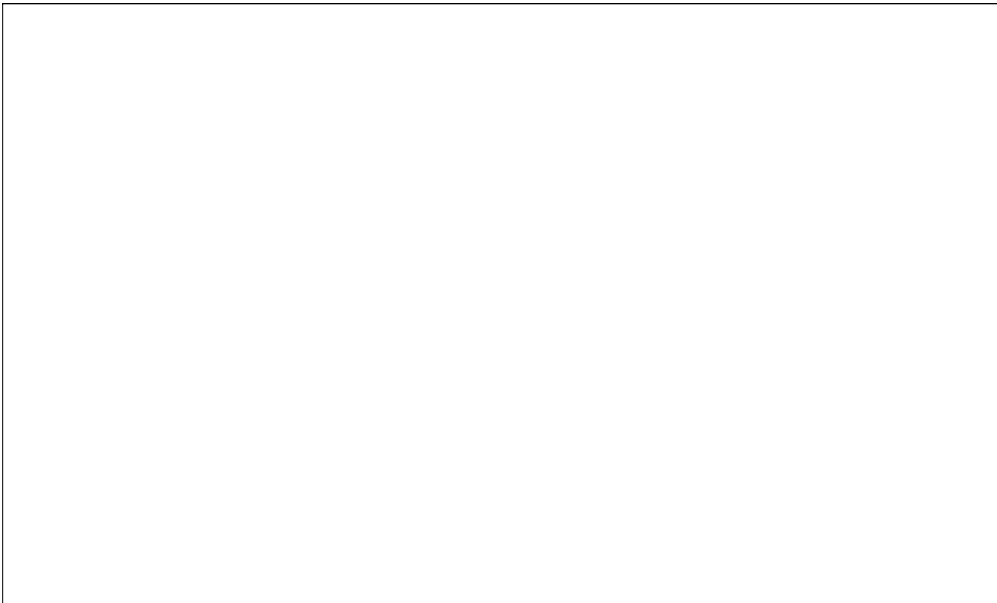
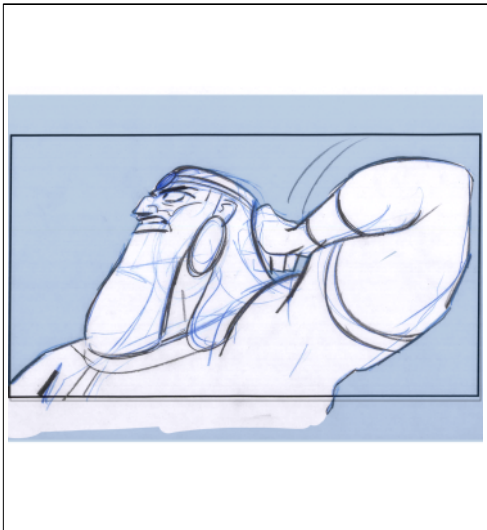

Seq	Scene	Panel
27	908	1

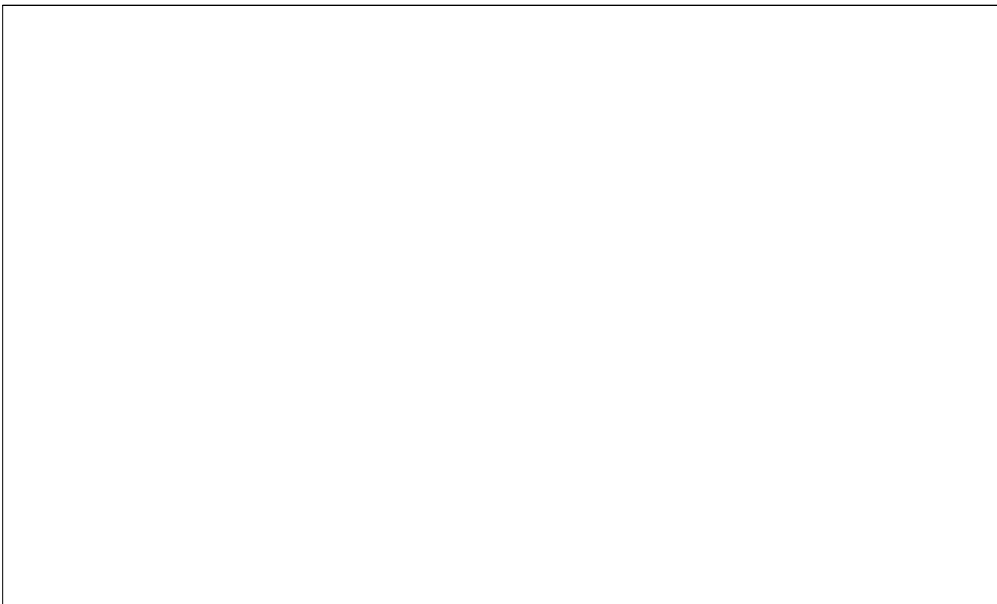

Seq	Scene	Panel
27	909	1



Seq	Scene	Panel
27	909	2

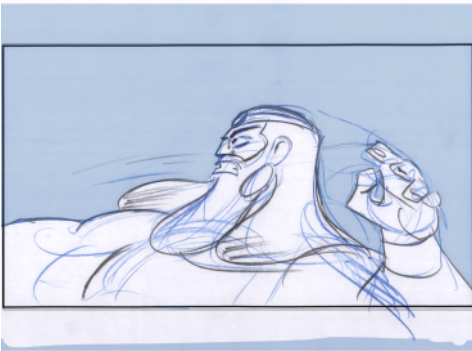

Seq	Scene	Panel
27	910	1

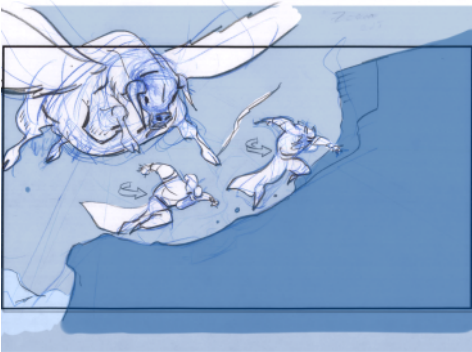

Seq	Scene	Panel
27	910	2

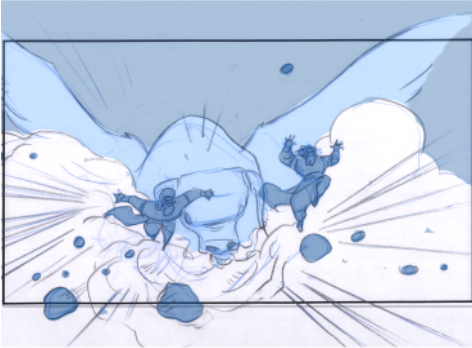

Seq	Scene	Panel
27	910	3

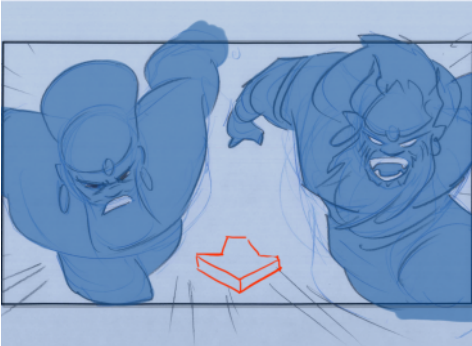

Seq	Scene	Panel
27	911	1

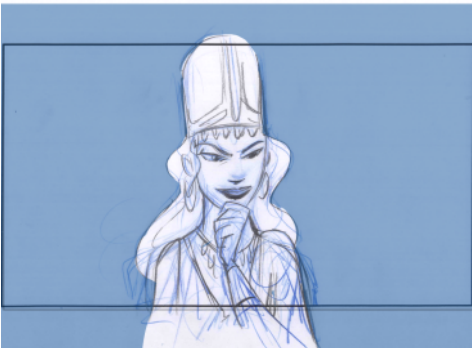

Seq	Scene	Panel
27	912	1

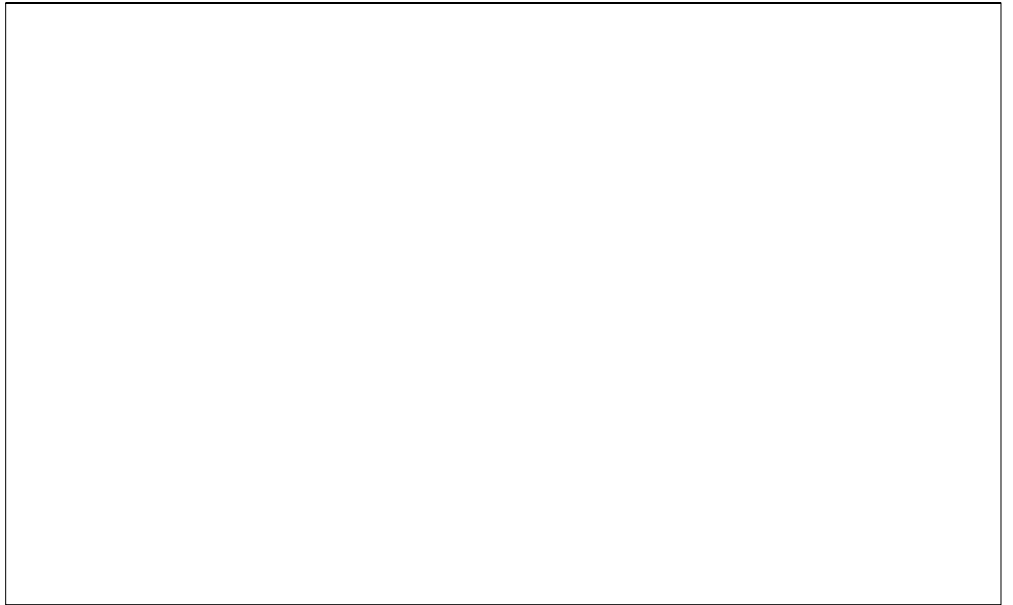
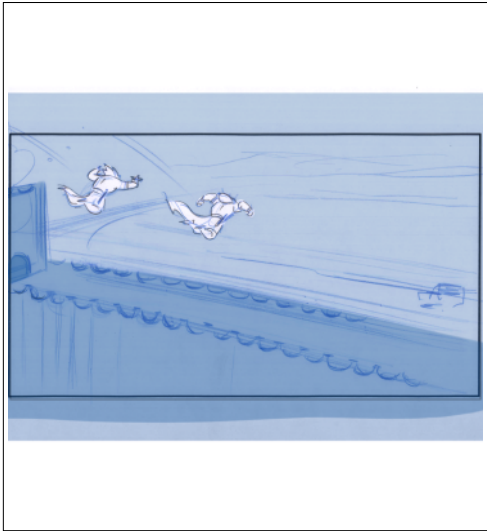

Seq	Scene	Panel
27	913	1

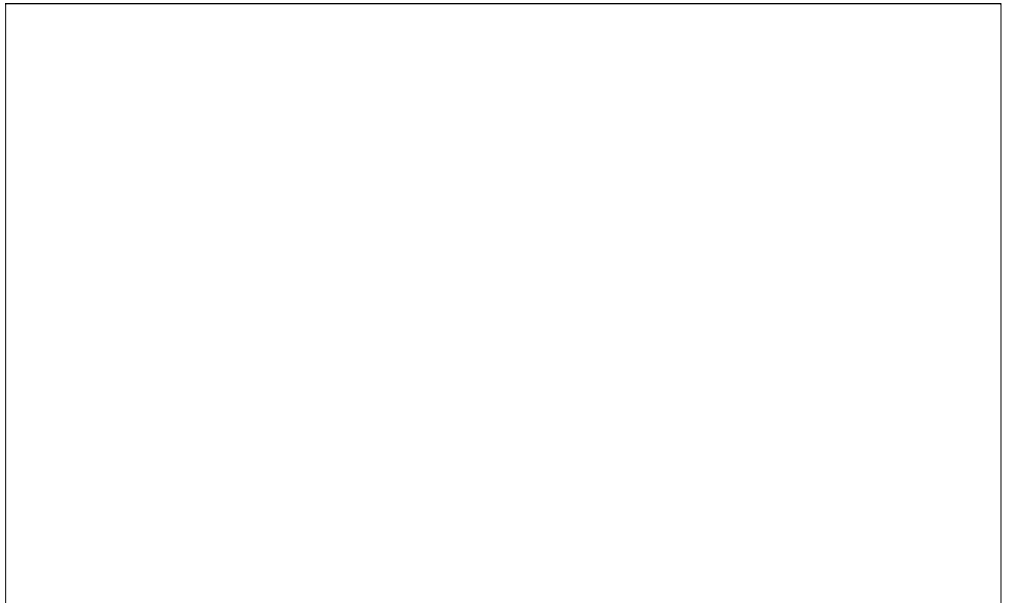
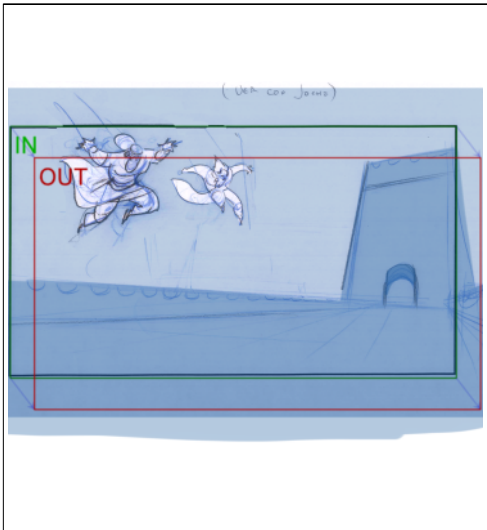

Seq	Scene	Panel
27	913	2

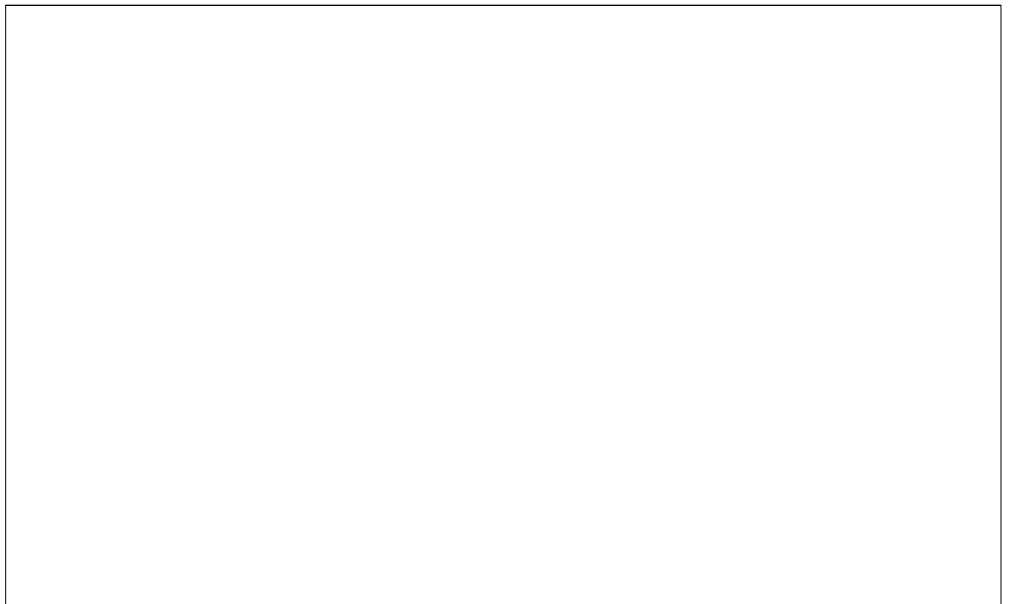
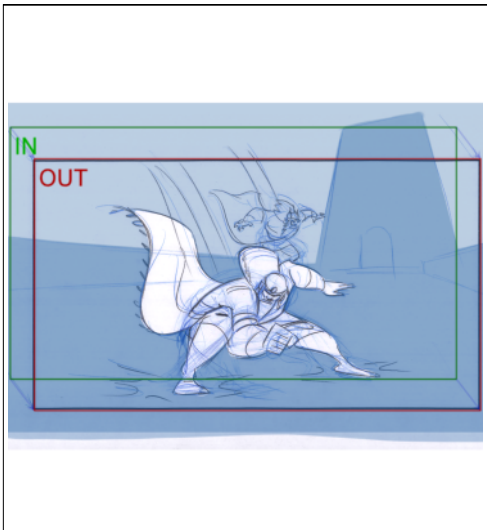

Seq	Scene	Panel
27	913	3

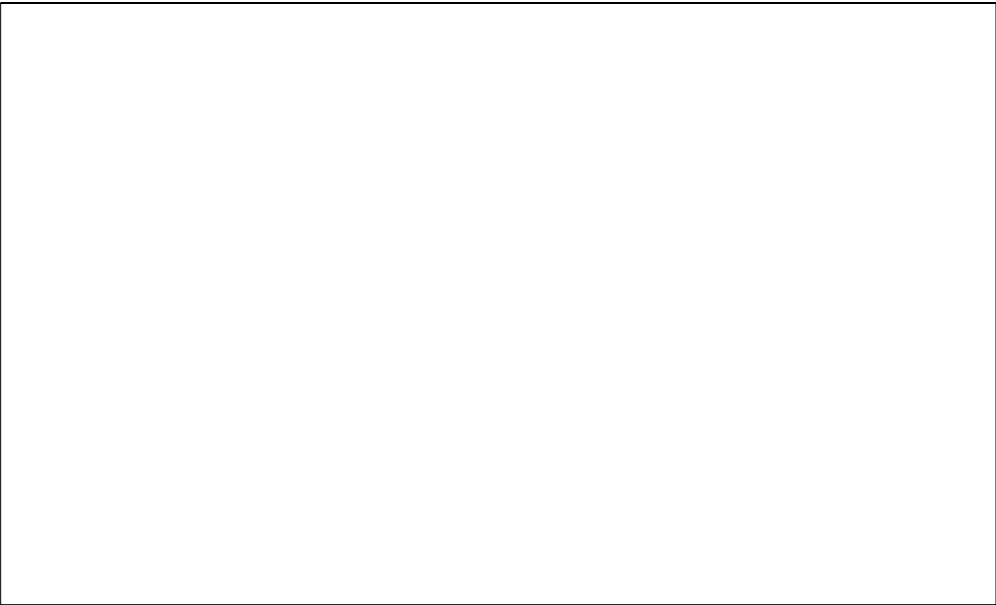
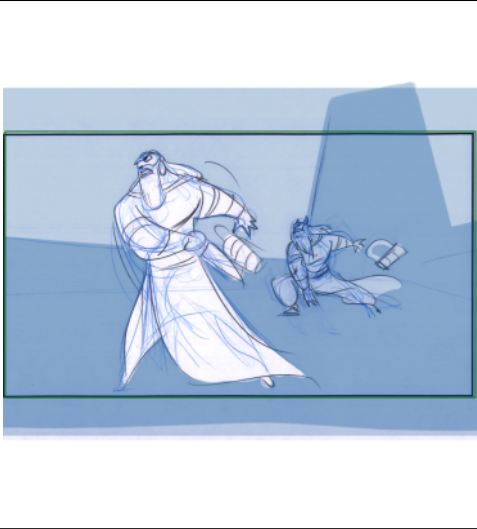

Seq	Scene	Panel
27	914	1

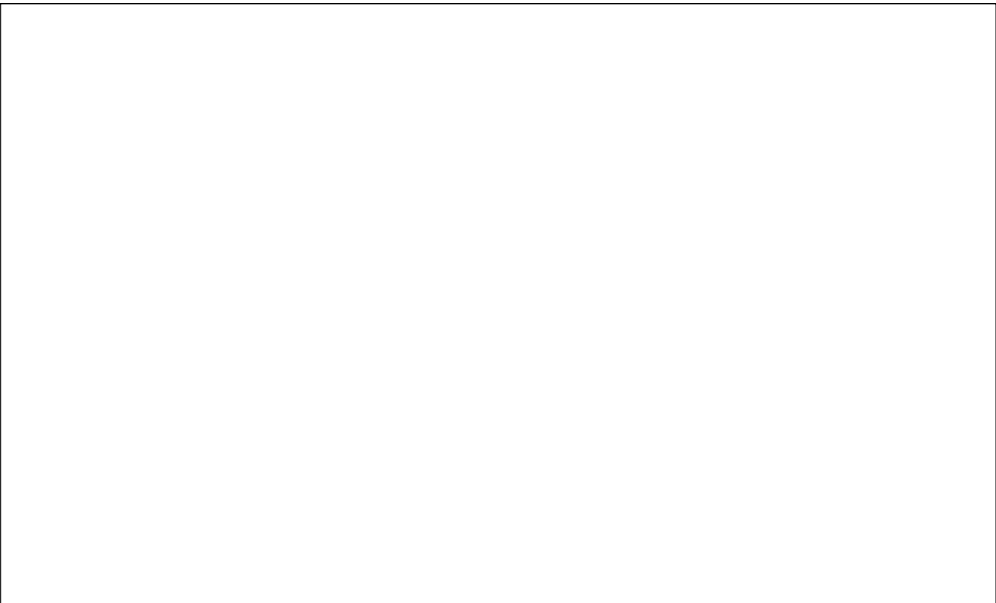
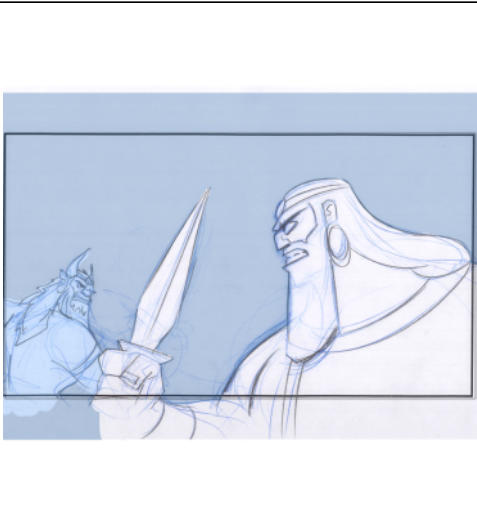

Seq	Scene	Panel
27	914	2

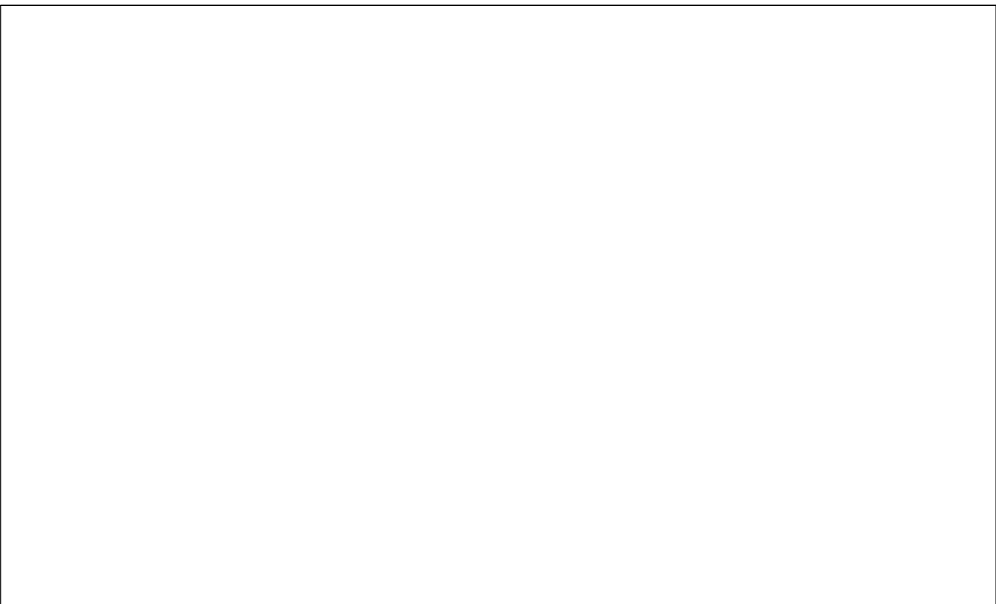

Seq	Scene	Panel
27	915	1

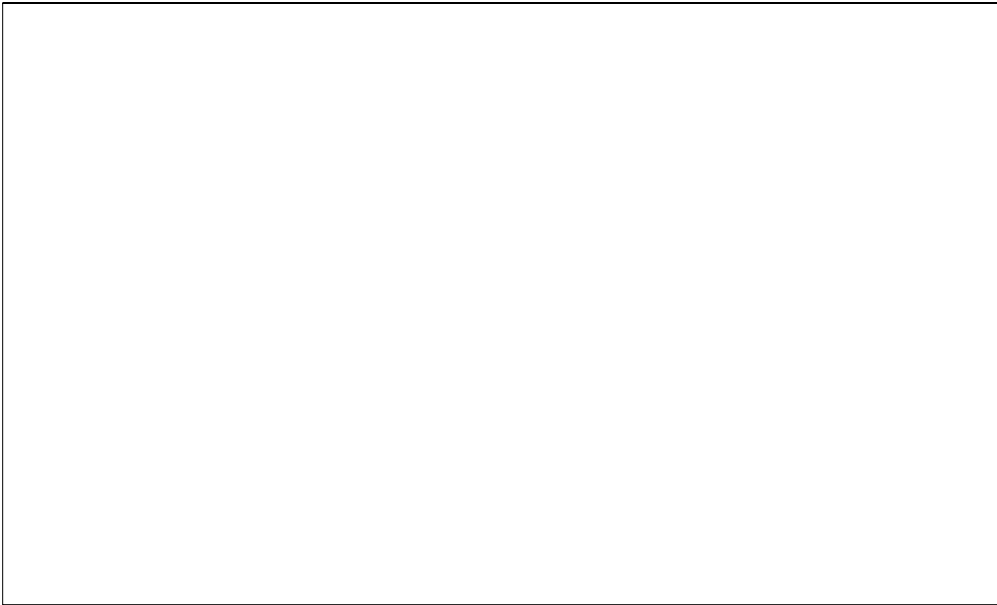
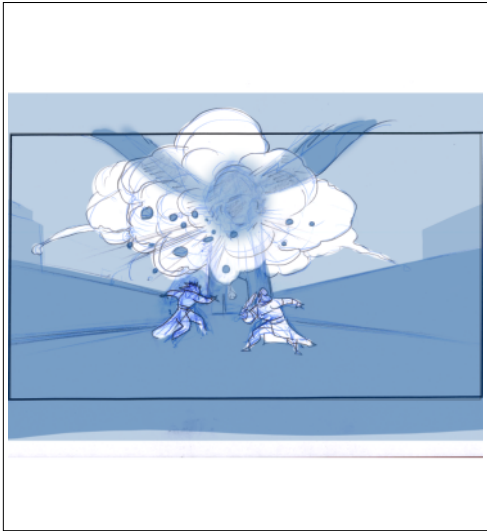

Seq	Scene	Panel
27	915	2

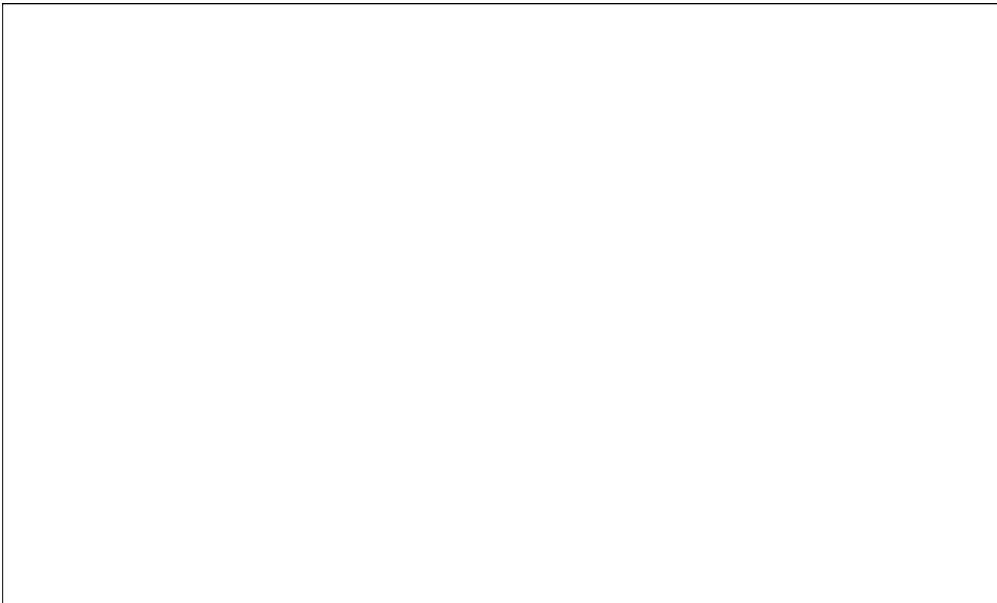
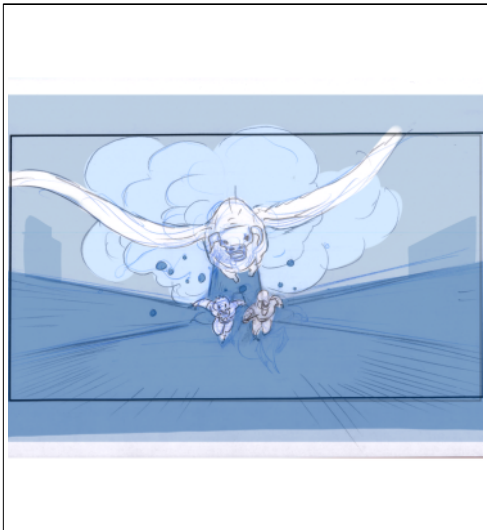

Seq	Scene	Panel
27	915	3

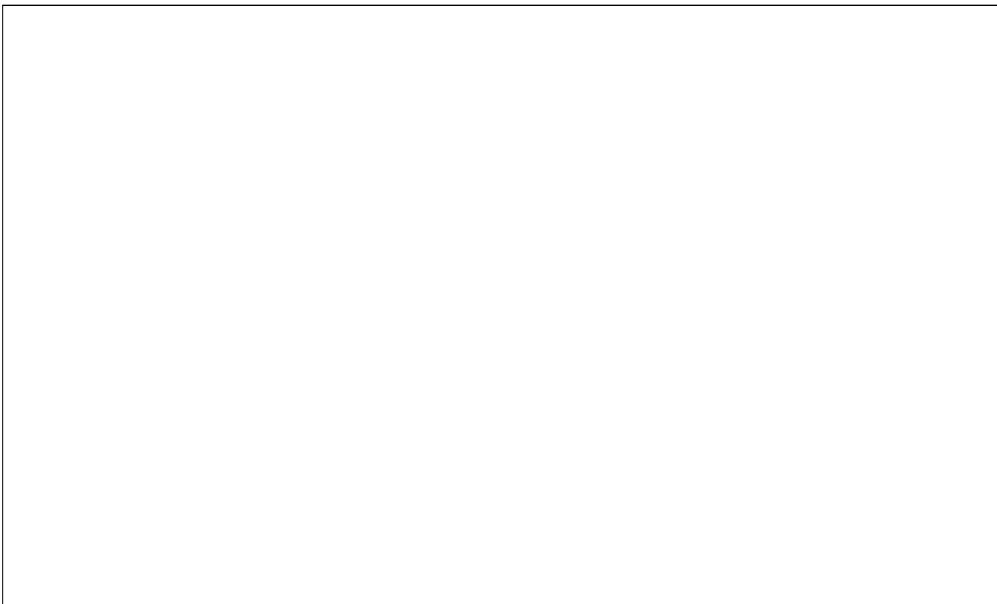
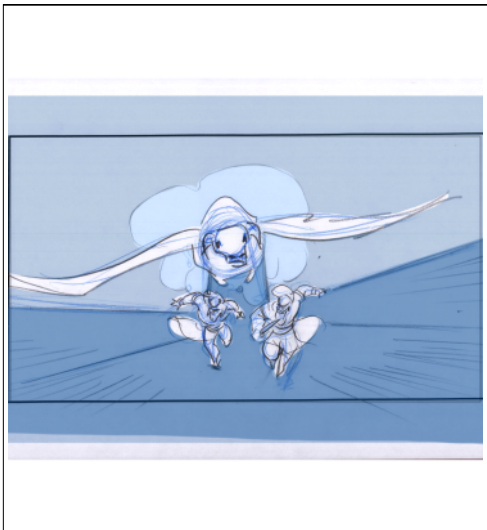

Seq	Scene	Panel
27	916	1

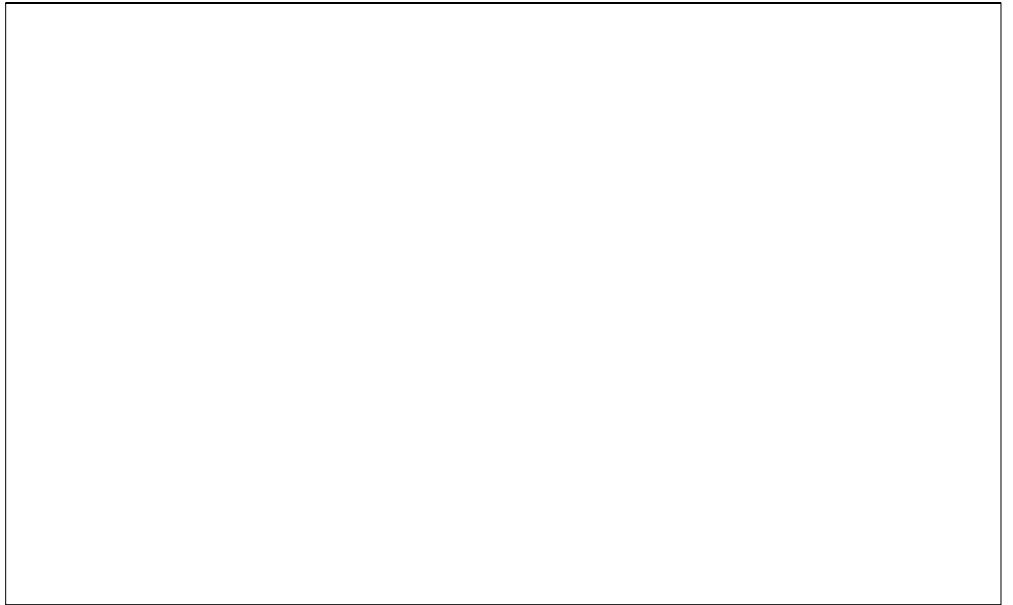
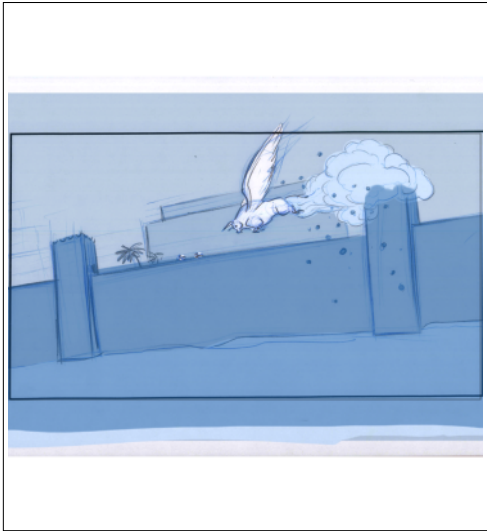

Seq	Scene	Panel
27	917	1

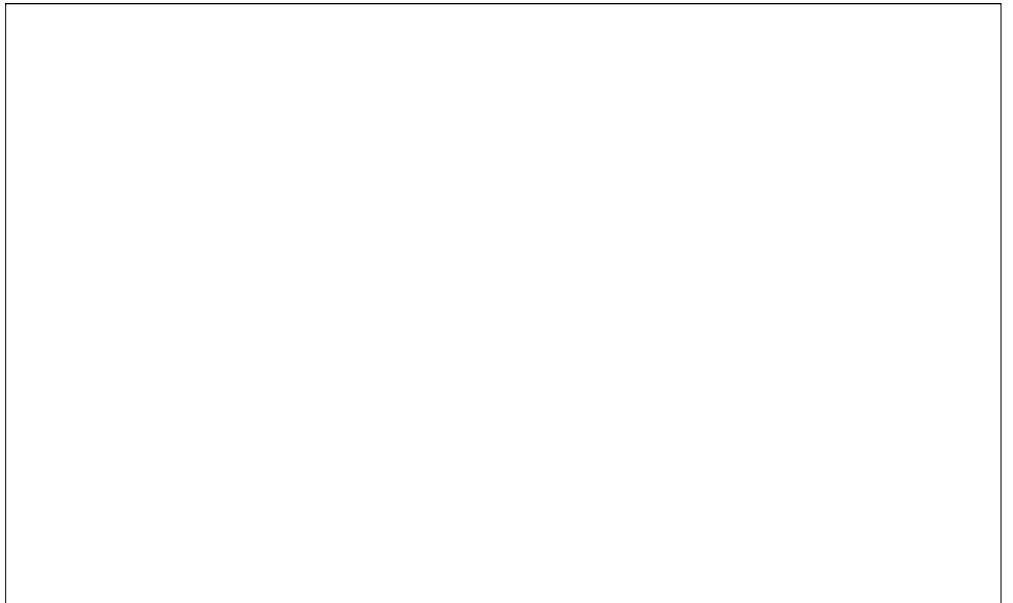
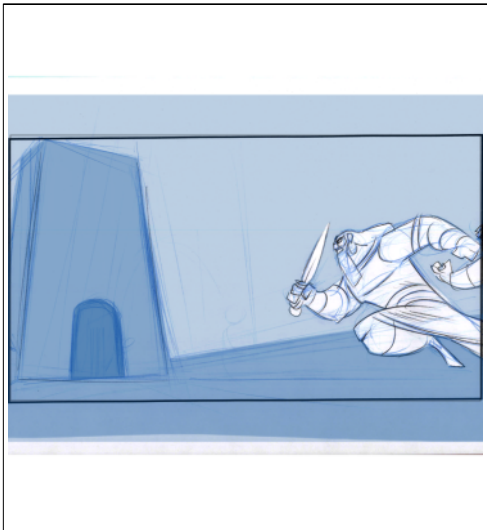

Seq	Scene	Panel
27	917	2

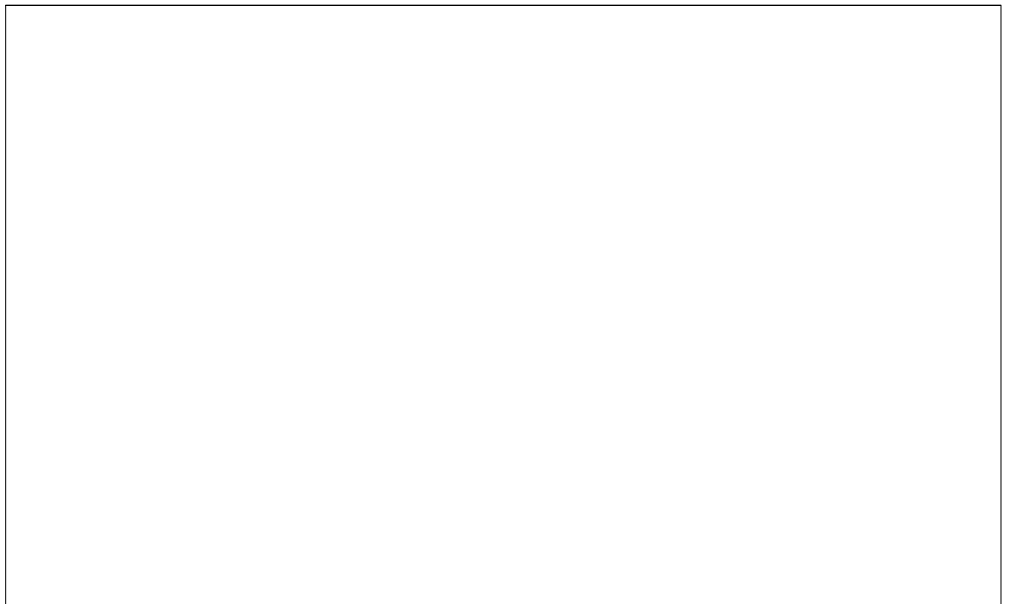
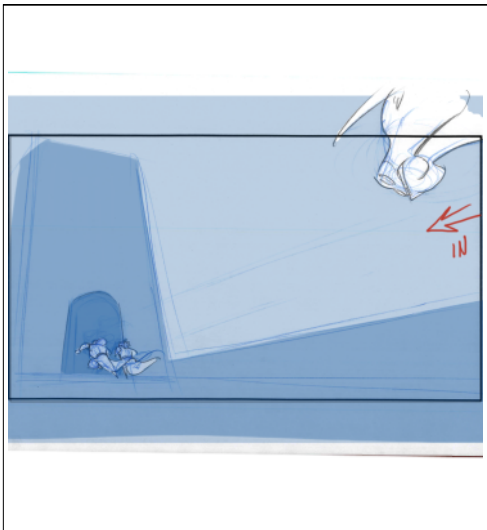

Seq	Scene	Panel
27	918	1

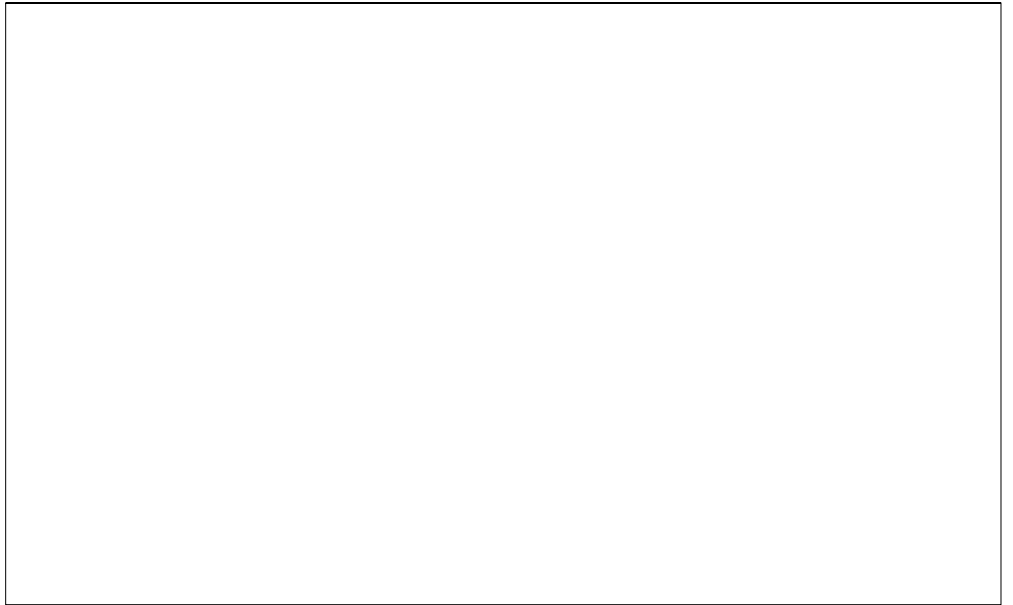
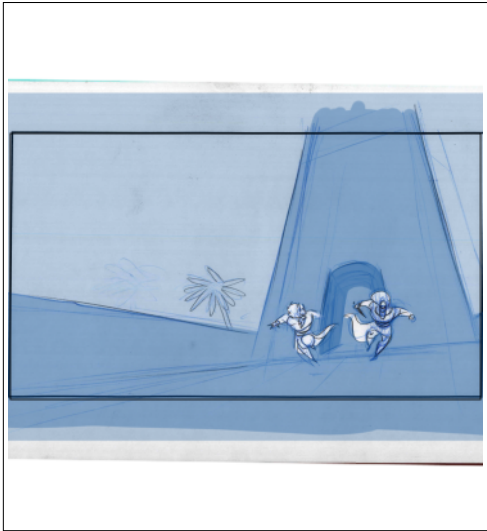

Seq	Scene	Panel
27	918	2

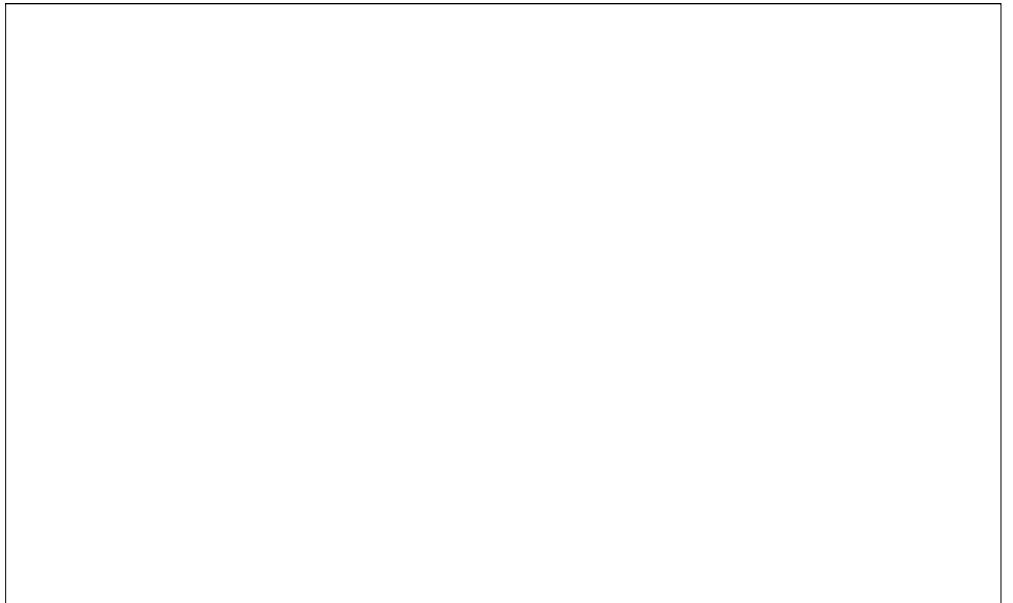
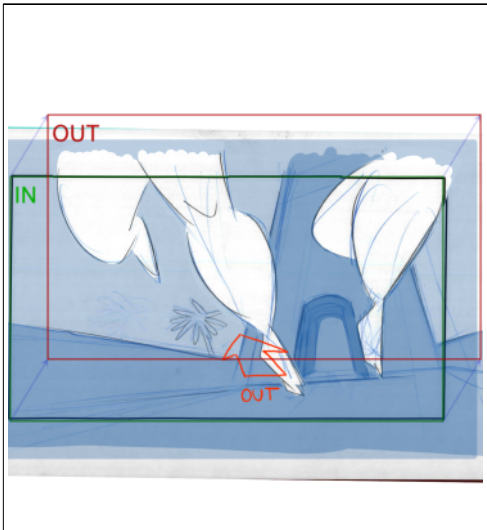

Seq	Scene	Panel
27	918	3

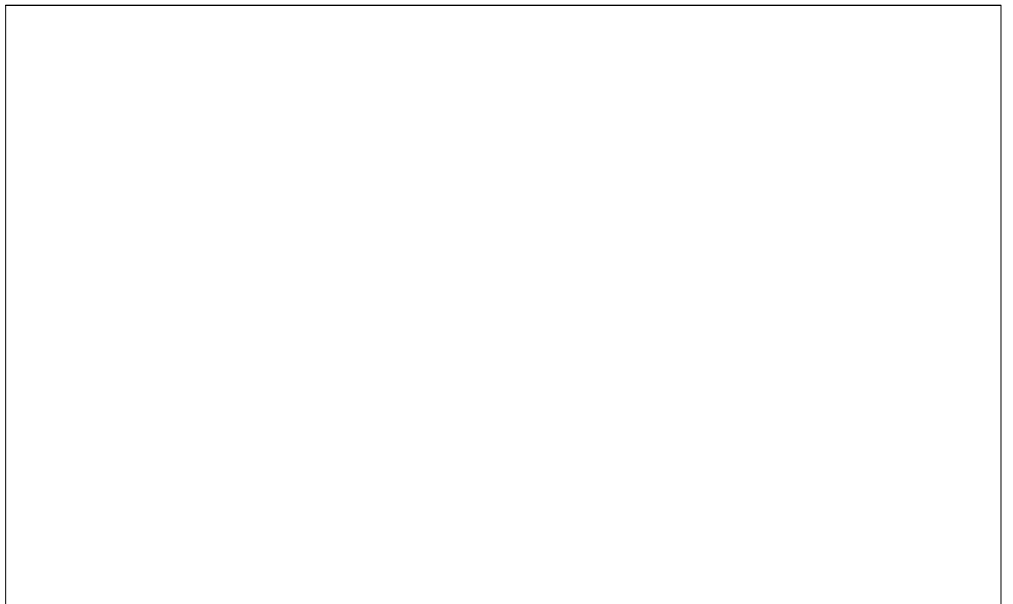
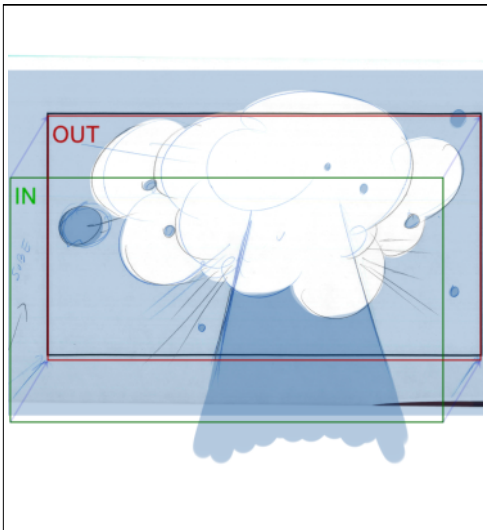

Seq	Scene	Panel
27	919	1

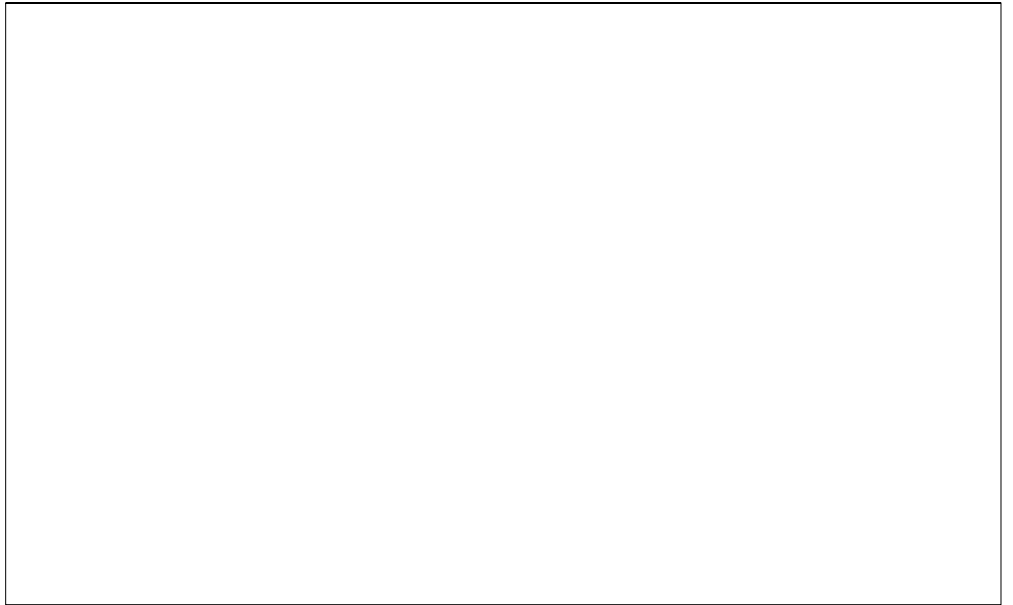
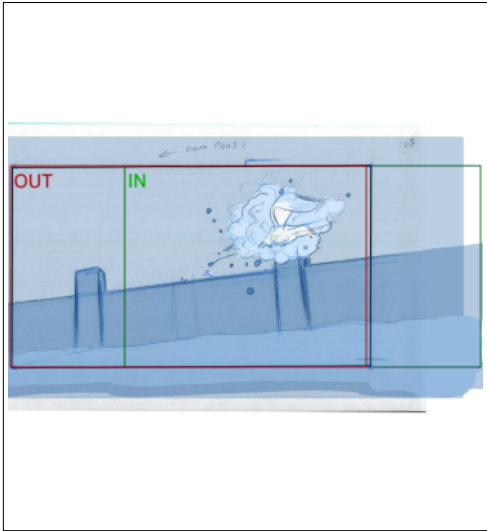

Seq	Scene	Panel
27	919	2

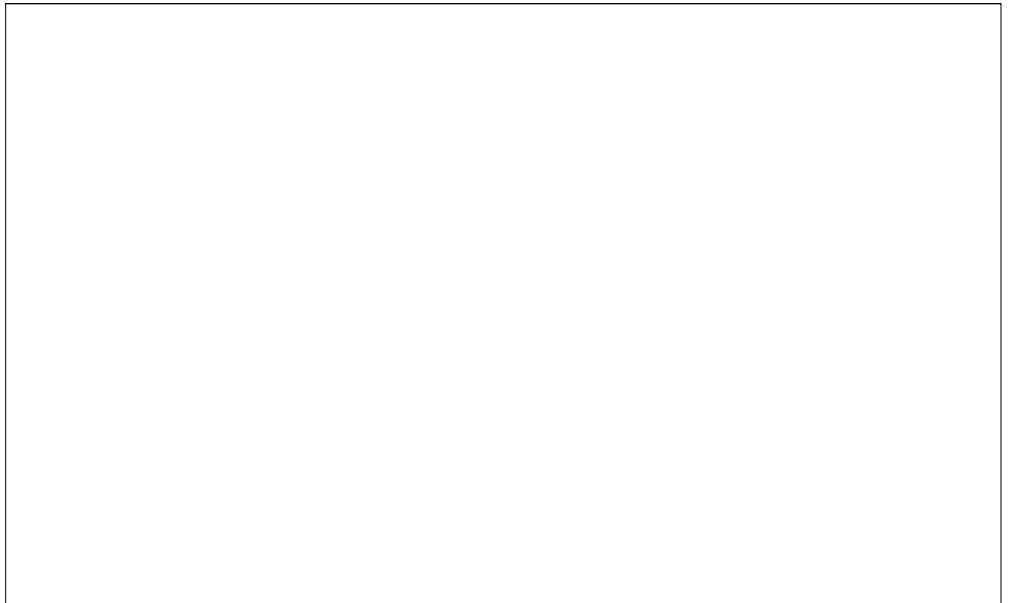
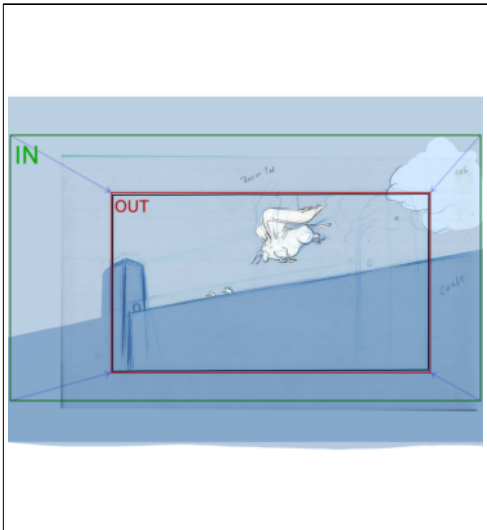

Seq	Scene	Panel
27	920	1

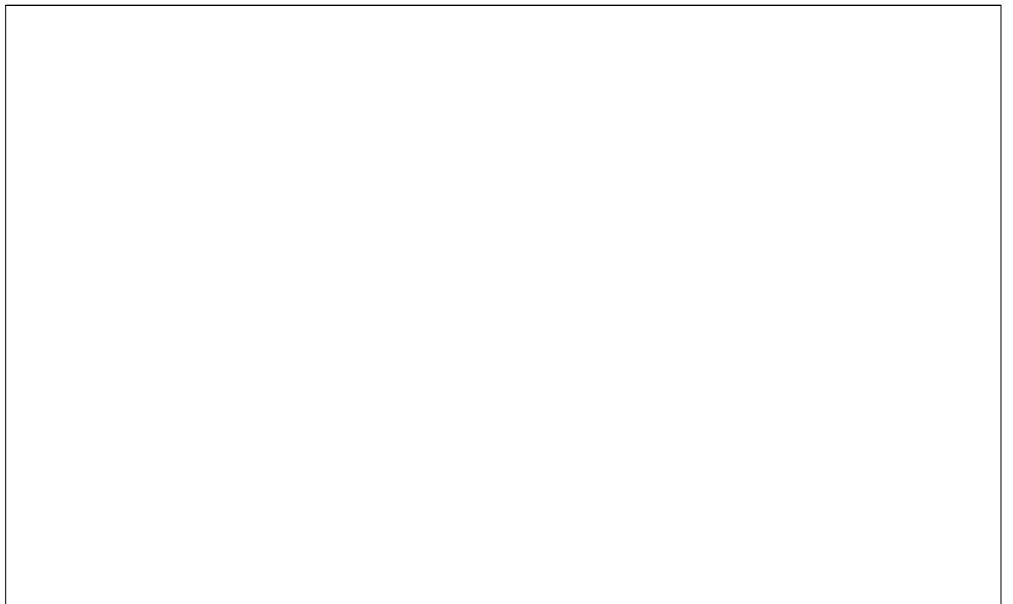
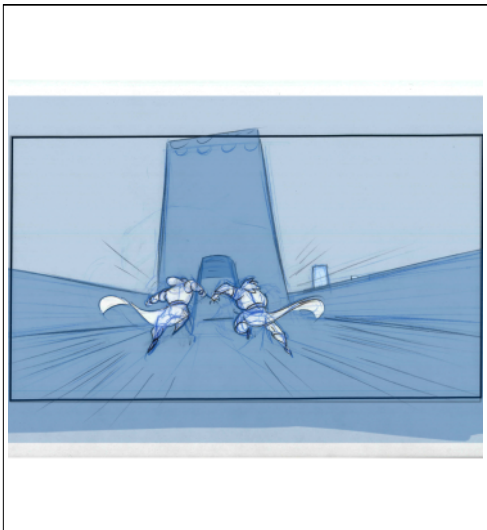

Seq	Scene	Panel
27	920	2

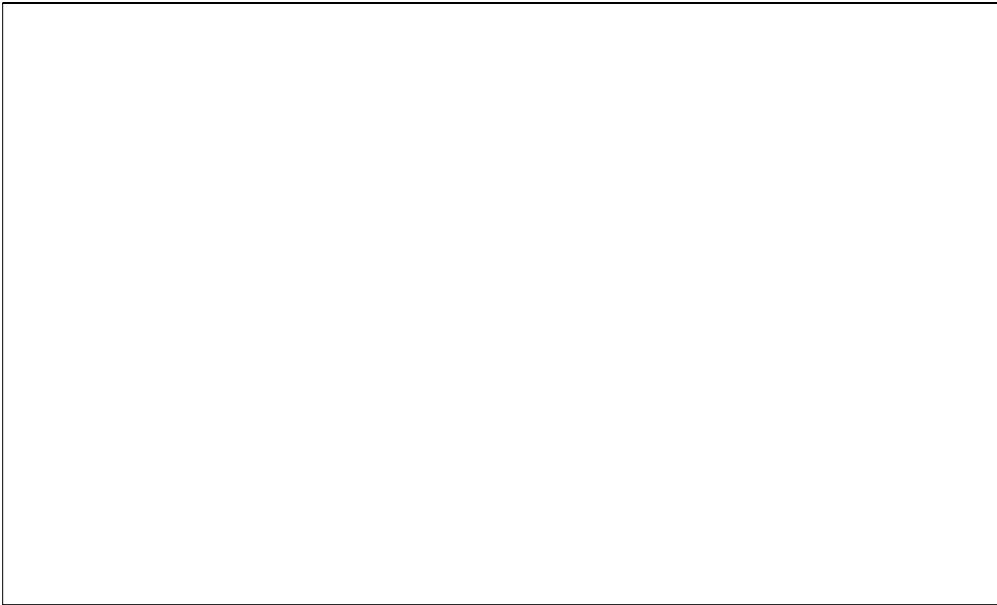
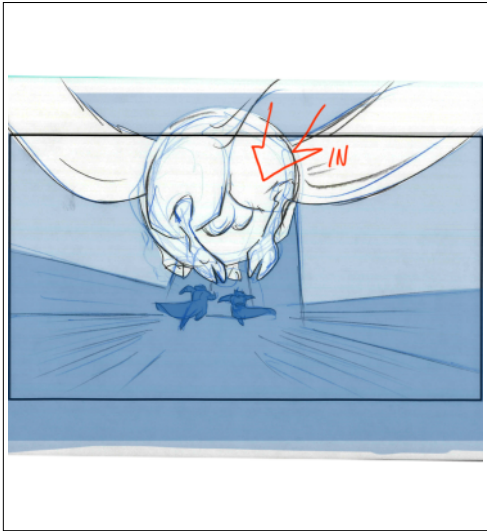

Seq	Scene	Panel
27	921	1

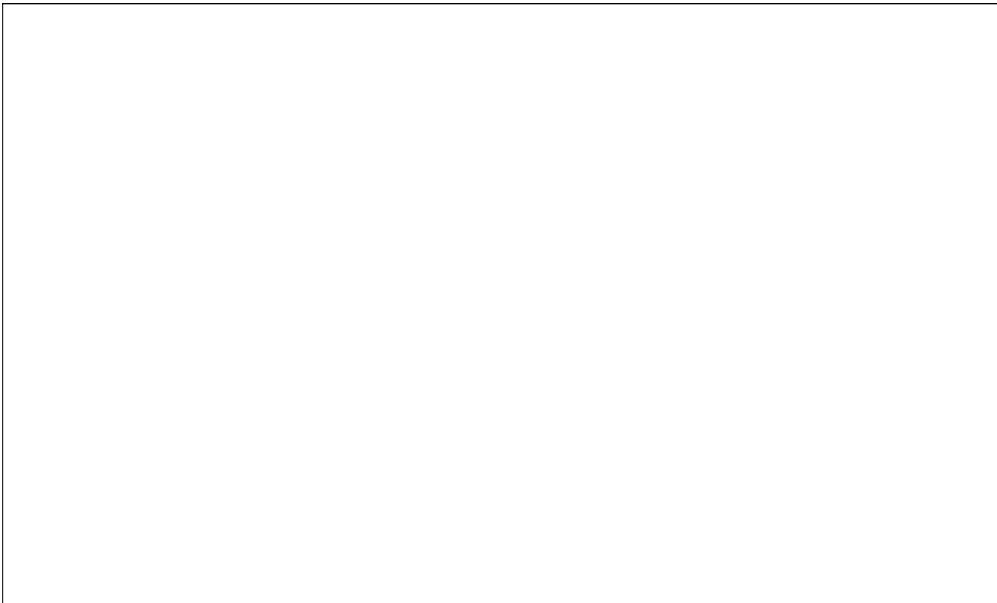

Seq	Scene	Panel
27	922	1

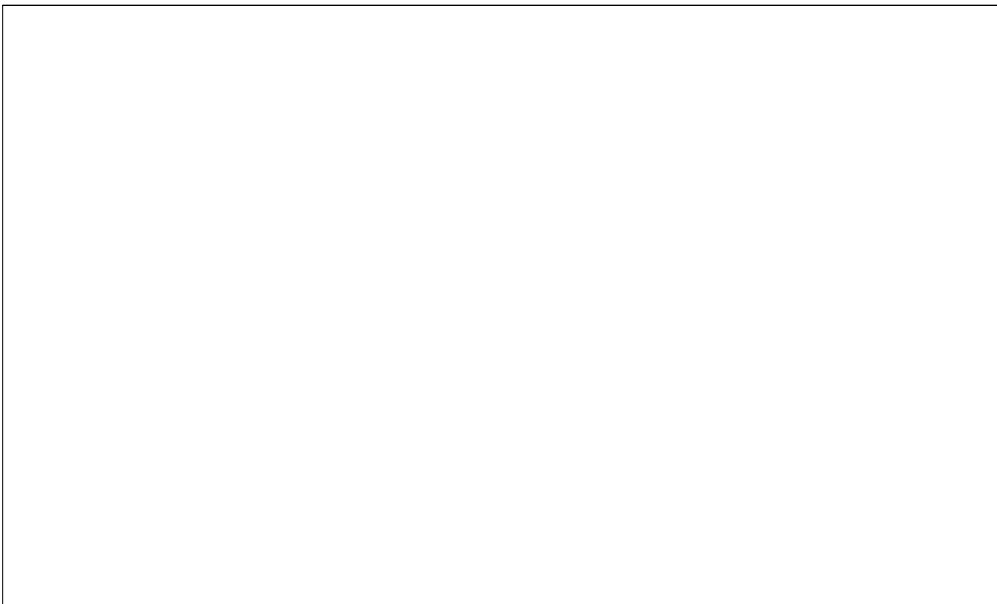
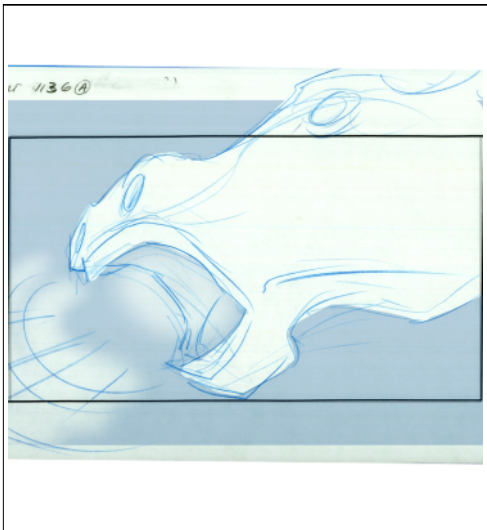

Seq	Scene	Panel
27	923	1

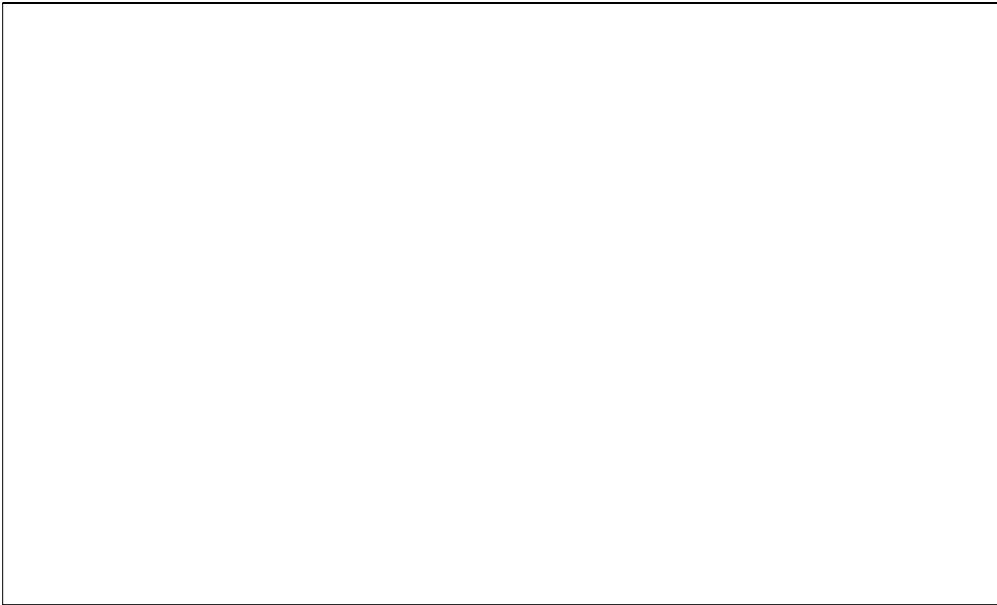

Seq	Scene	Panel
27	923	2

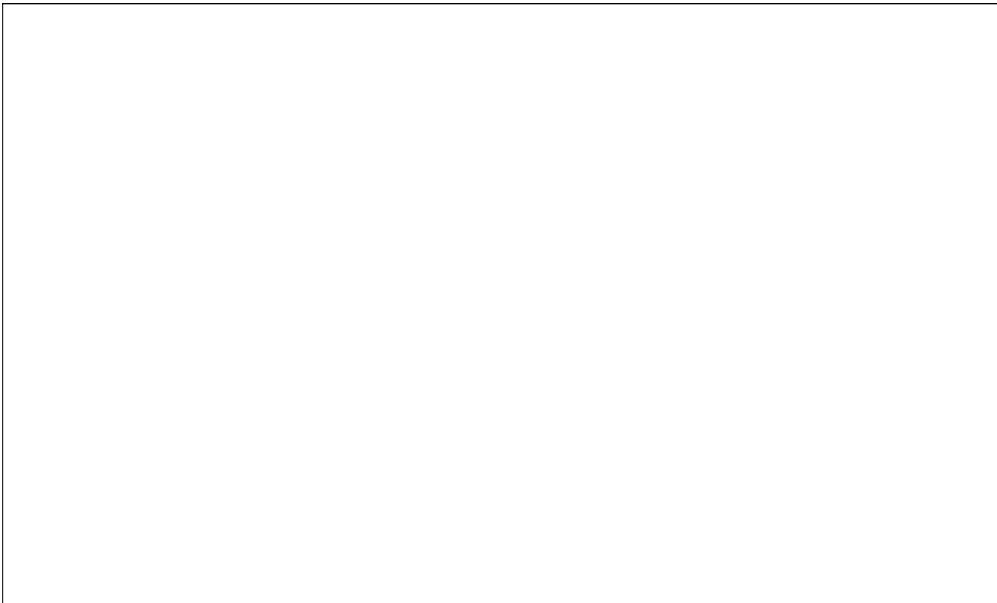

Seq	Scene	Panel
27	923	3

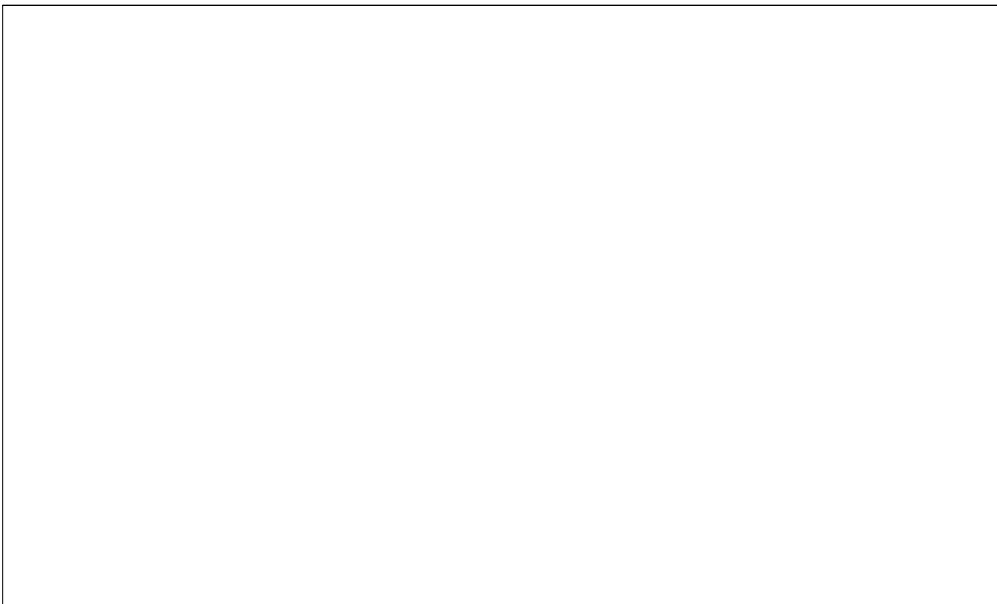

Seq	Scene	Panel
27	924	1

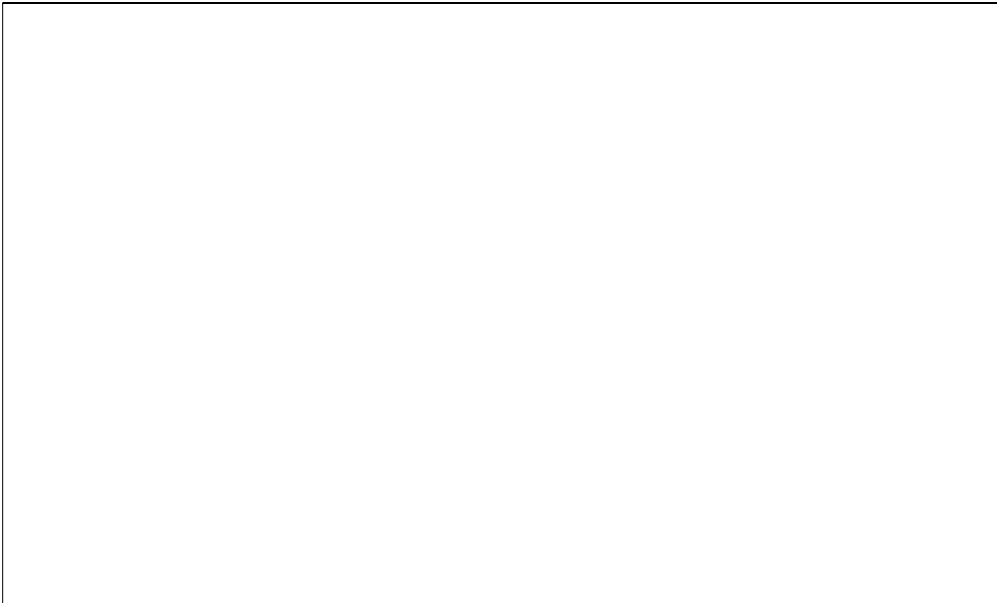
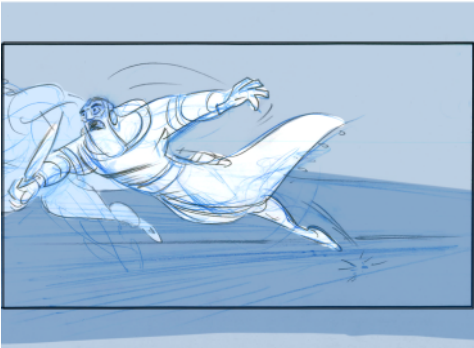

Seq	Scene	Panel
27	924	2

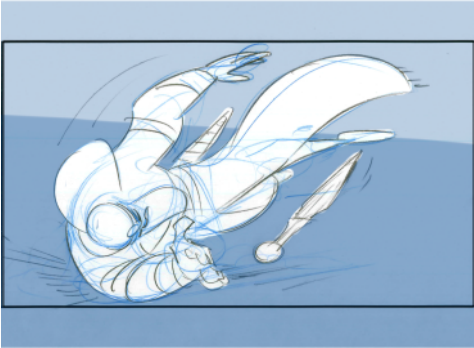

Seq	Scene	Panel
27	924	3

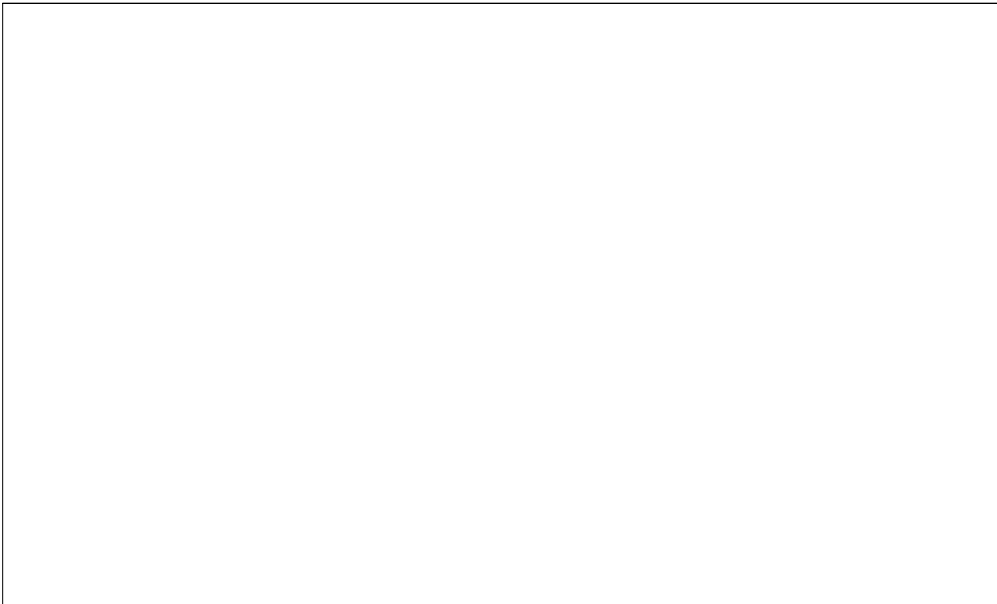
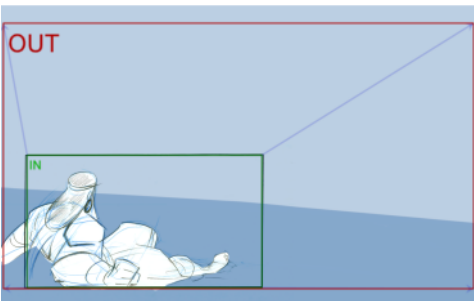

Seq	Scene	Panel
27	924	4

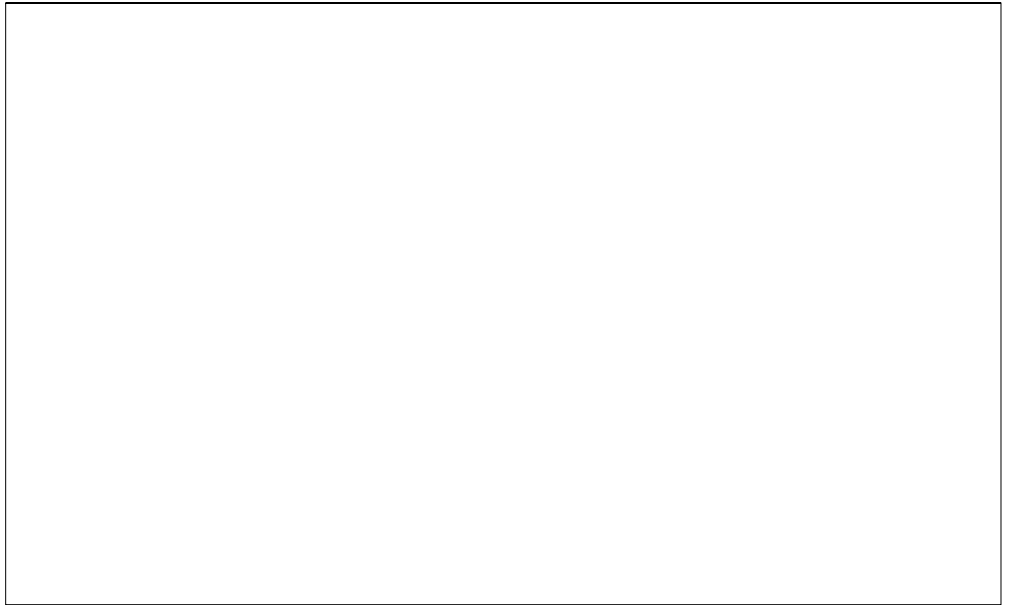
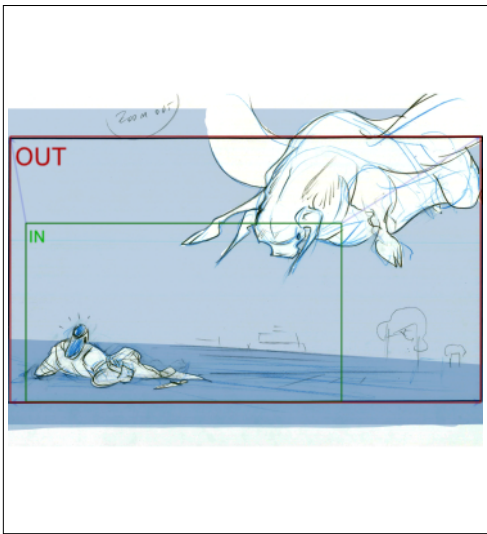

Seq	Scene	Panel
27	924	5

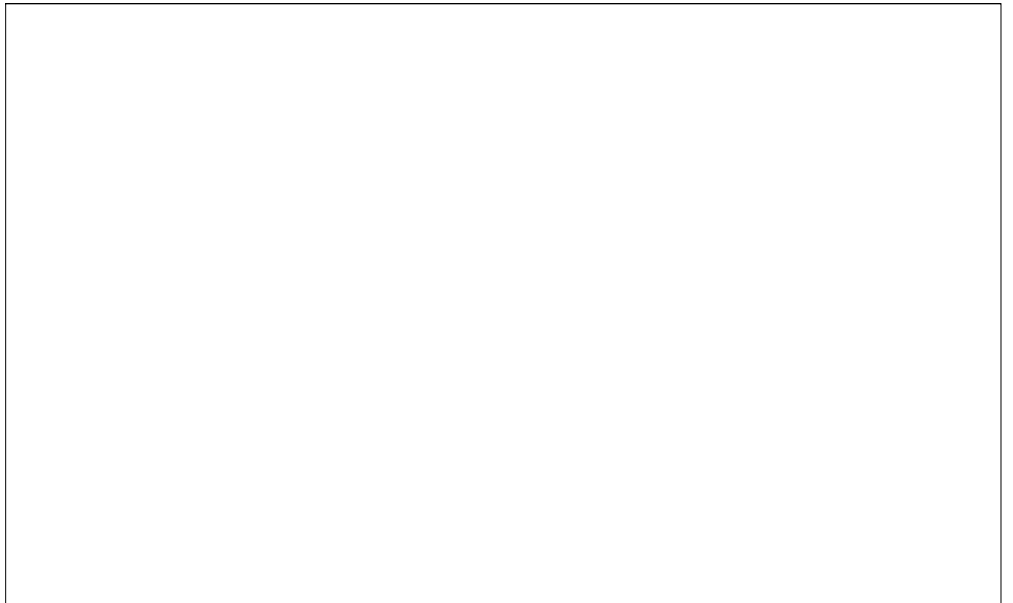
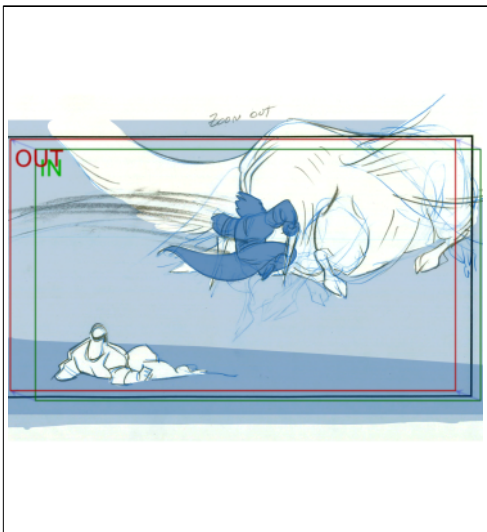

Seq	Scene	Panel
27	924	6

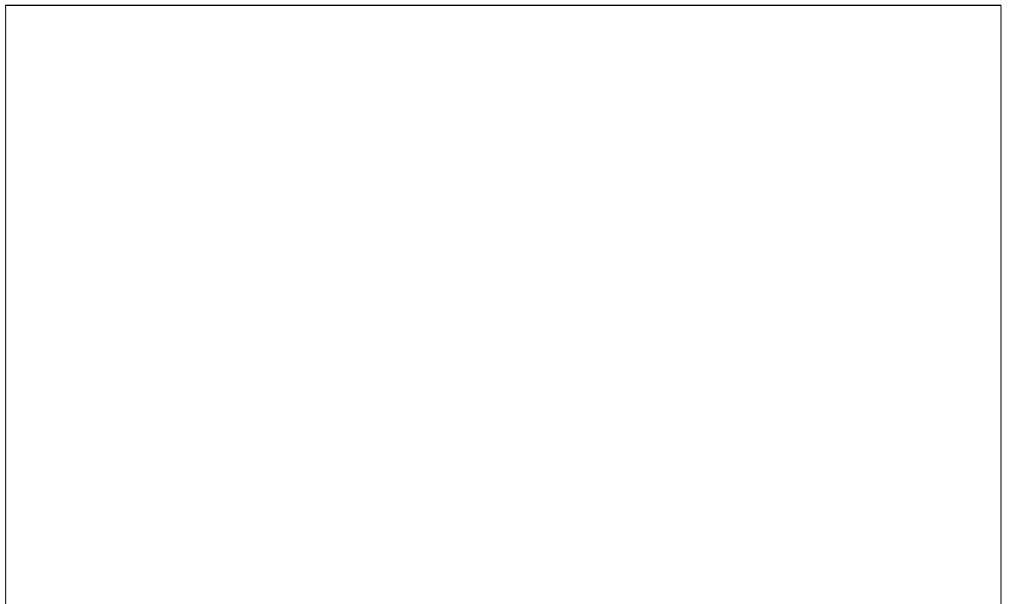
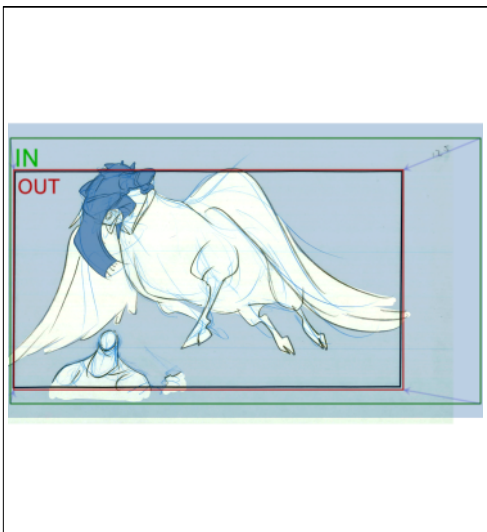

Seq	Scene	Panel
27	924	7

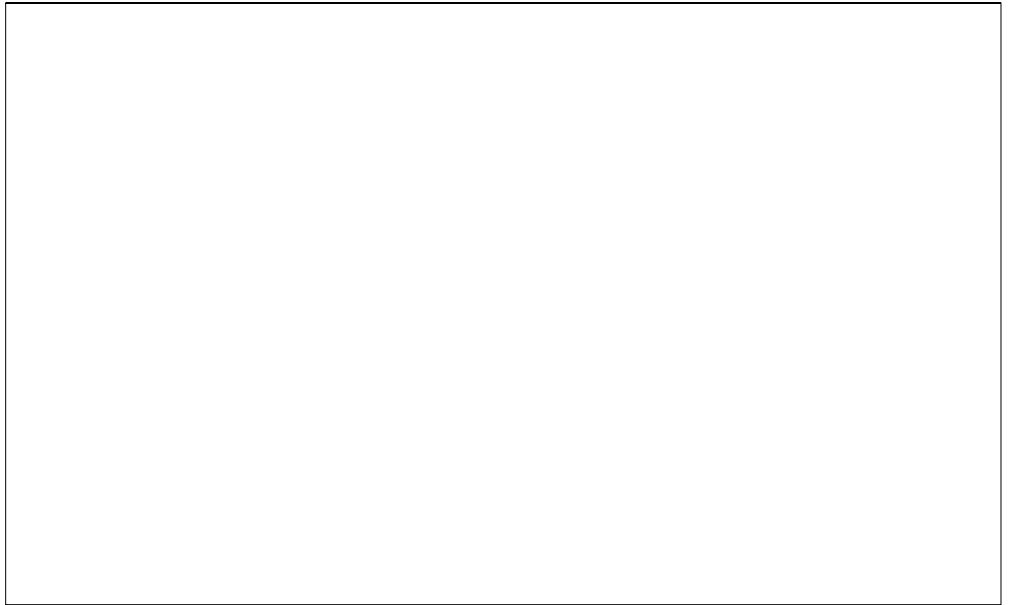
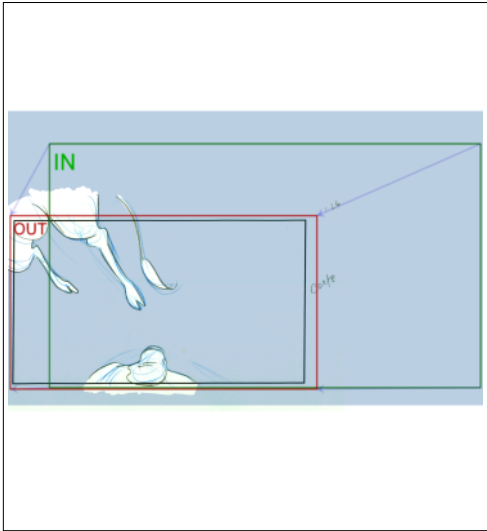

Seq	Scene	Panel
27	925	1

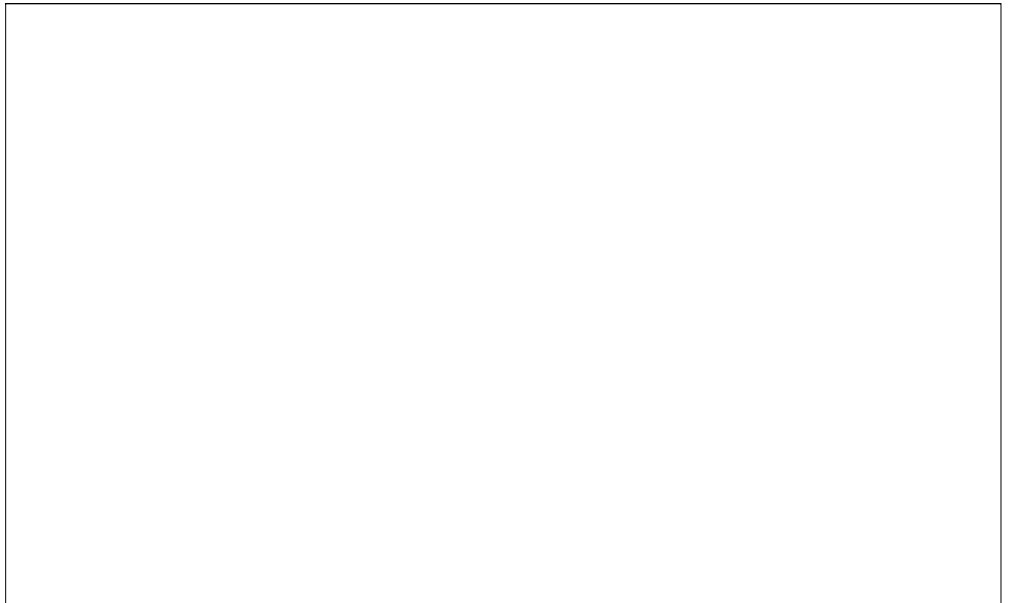
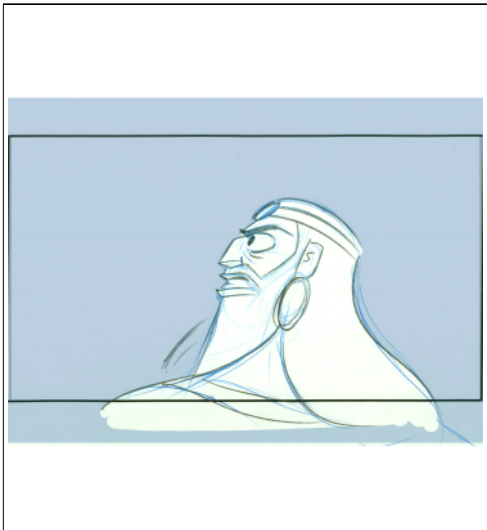

Seq	Scene	Panel
27	926	1

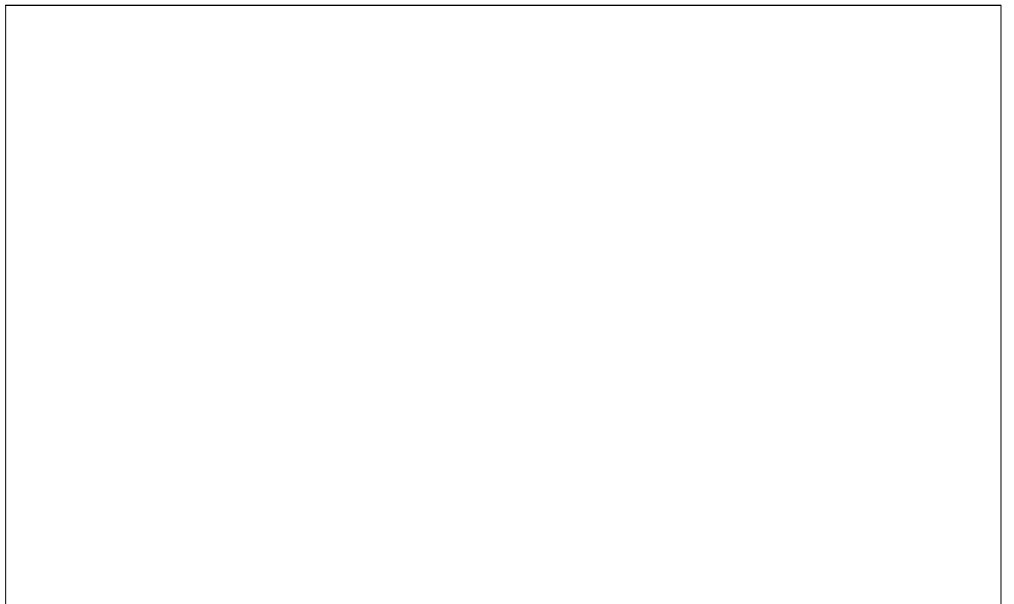
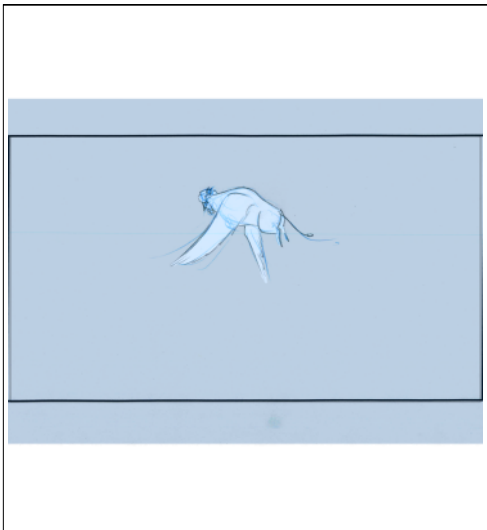

Seq	Scene	Panel
27	926	2

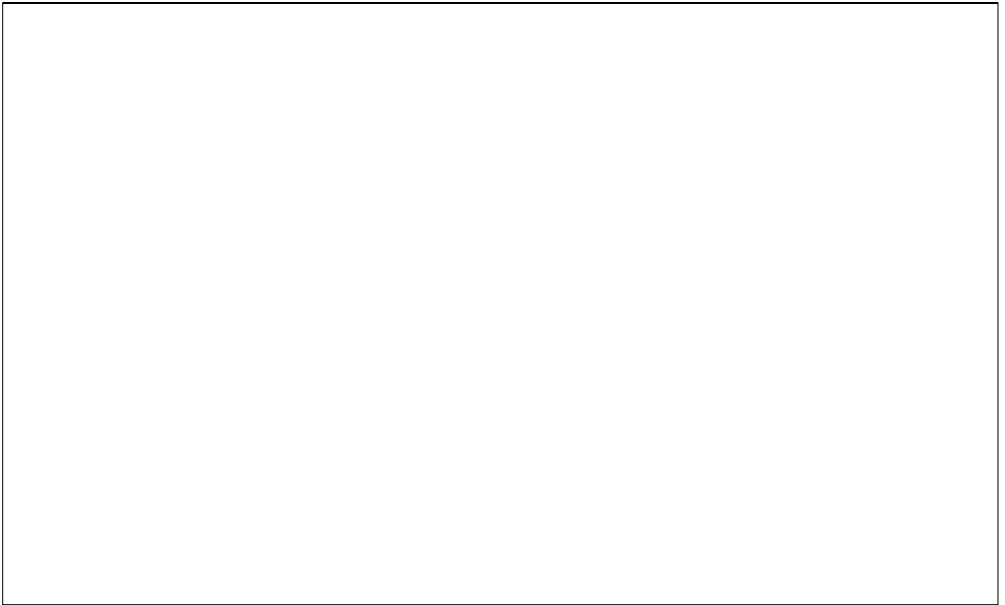
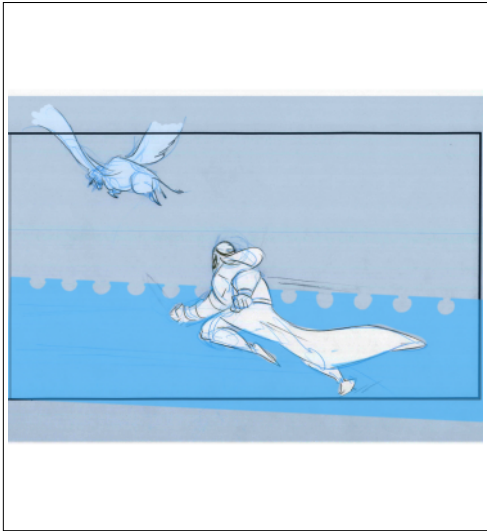

Seq	Scene	Panel
27	927	1

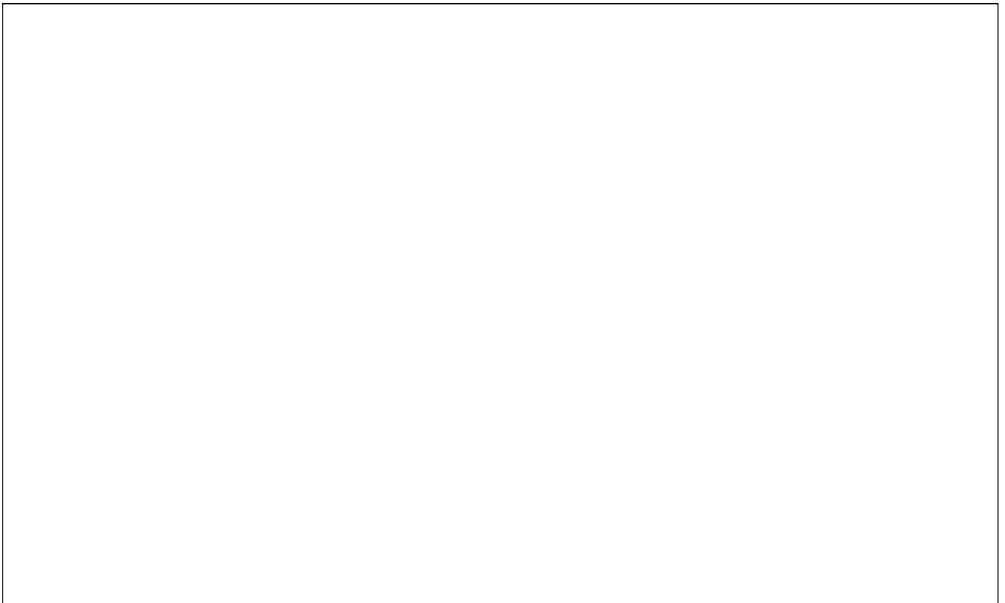

Seq	Scene	Panel
27	927	2

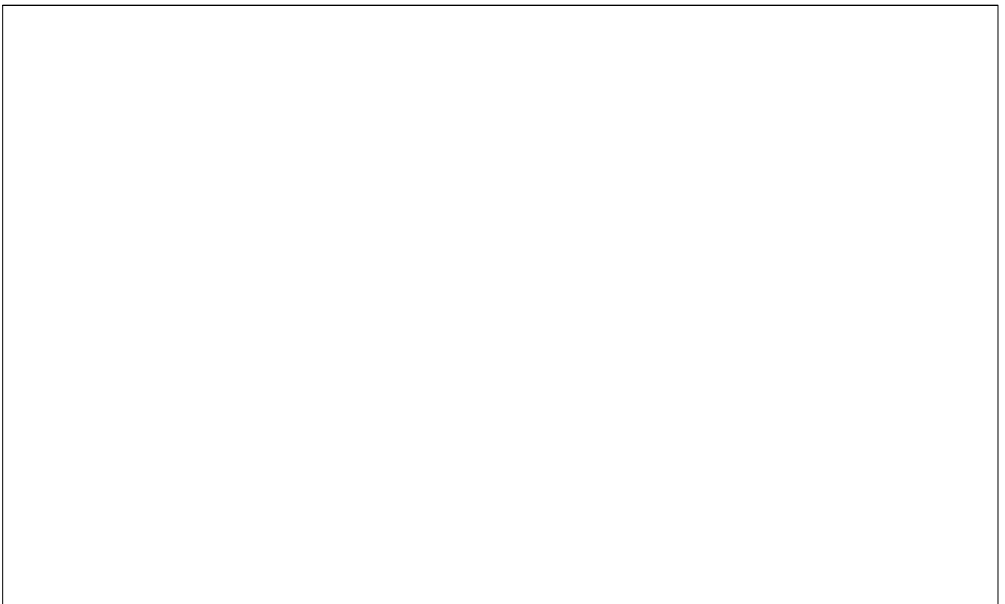
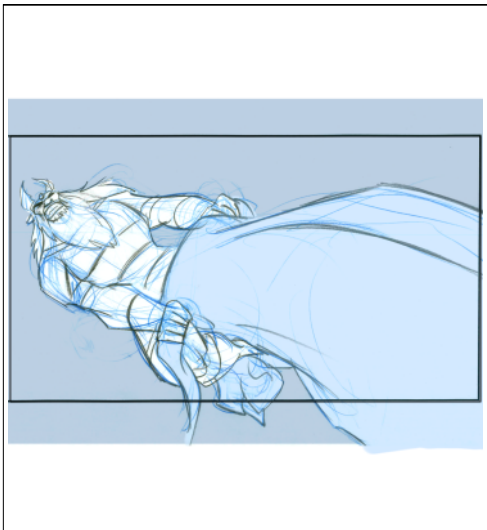

Seq	Scene	Panel
27	927	3

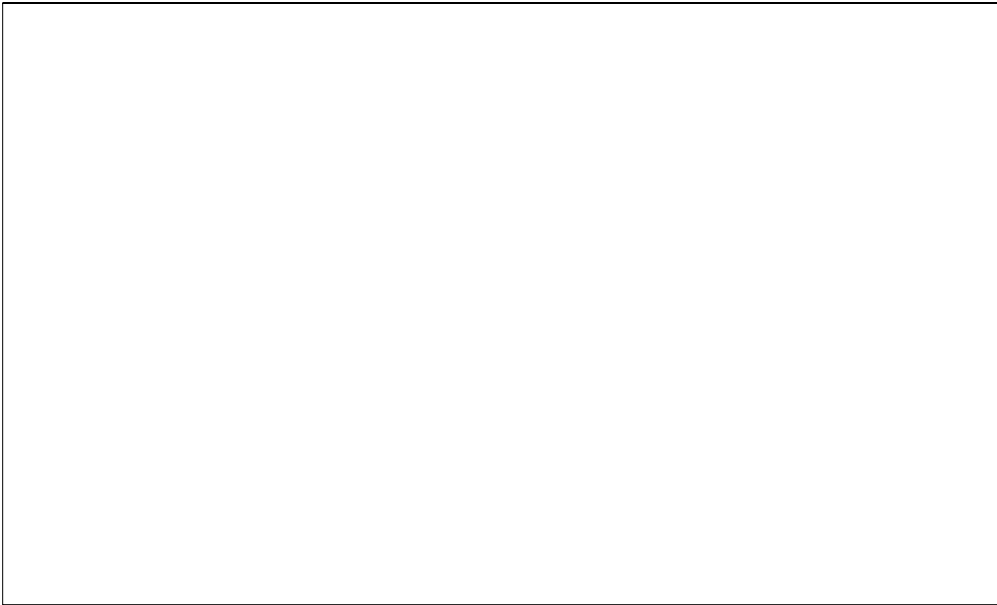
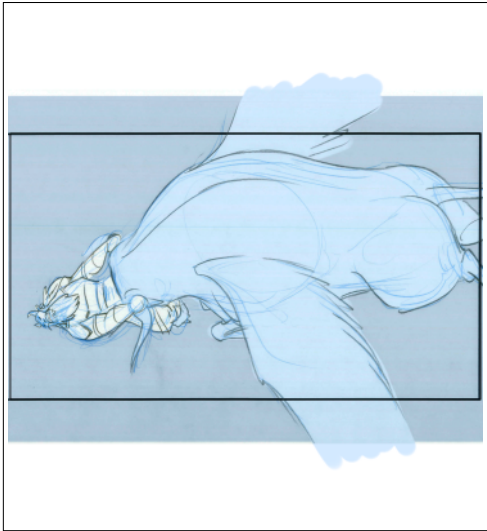

Seq	Scene	Panel
27	927	4

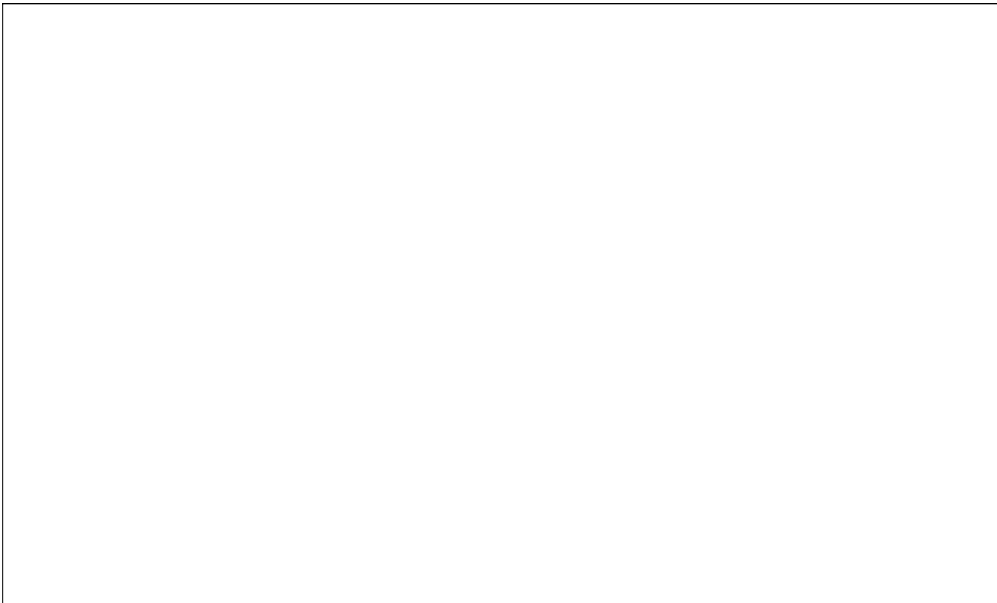
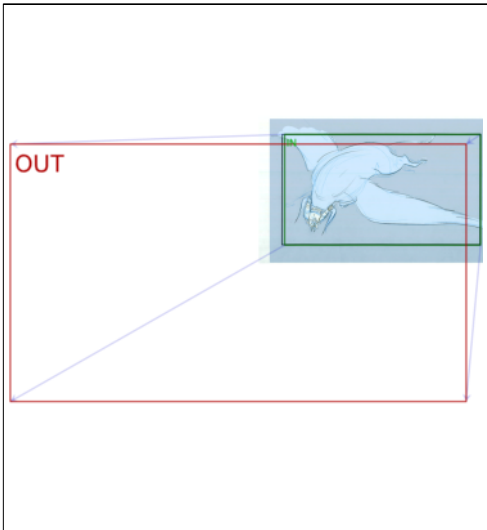

Seq	Scene	Panel
27	927	5

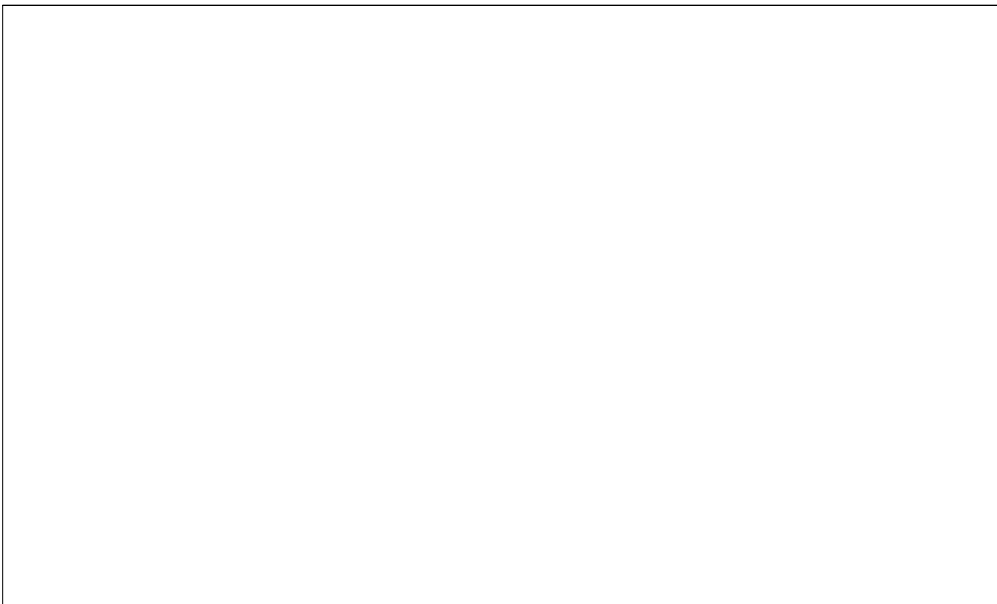
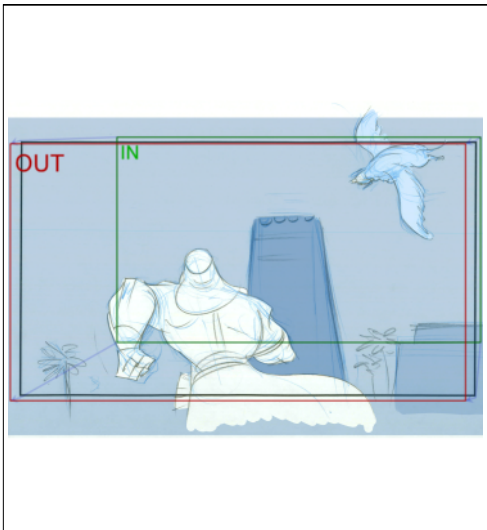

Seq	Scene	Panel
27	927	6

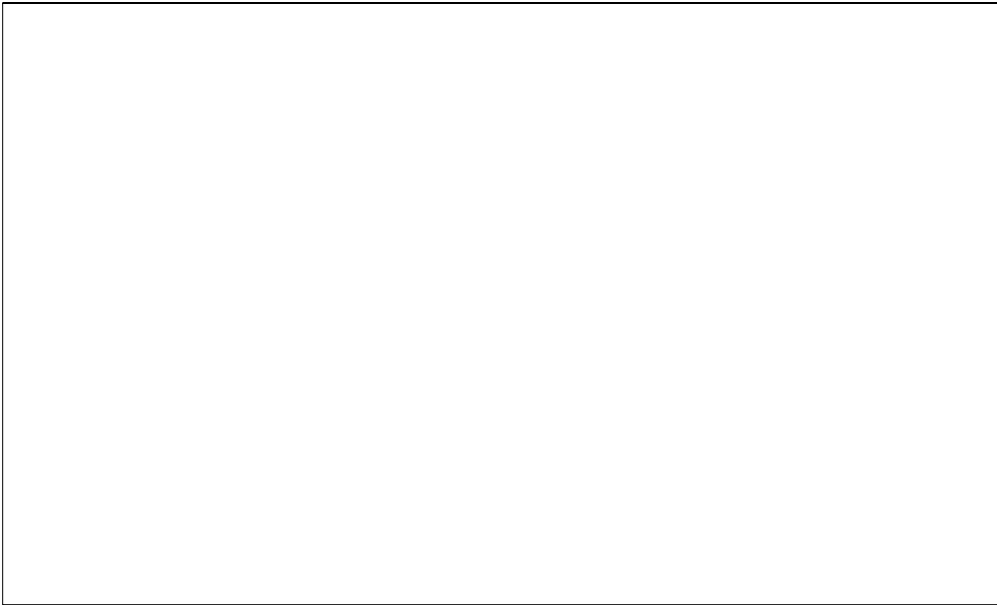
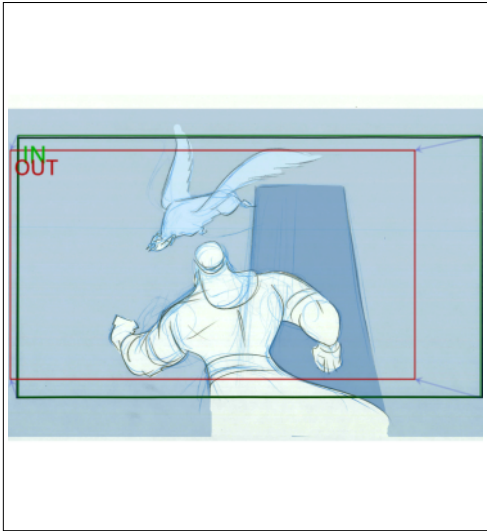

Seq	Scene	Panel
27	928	1

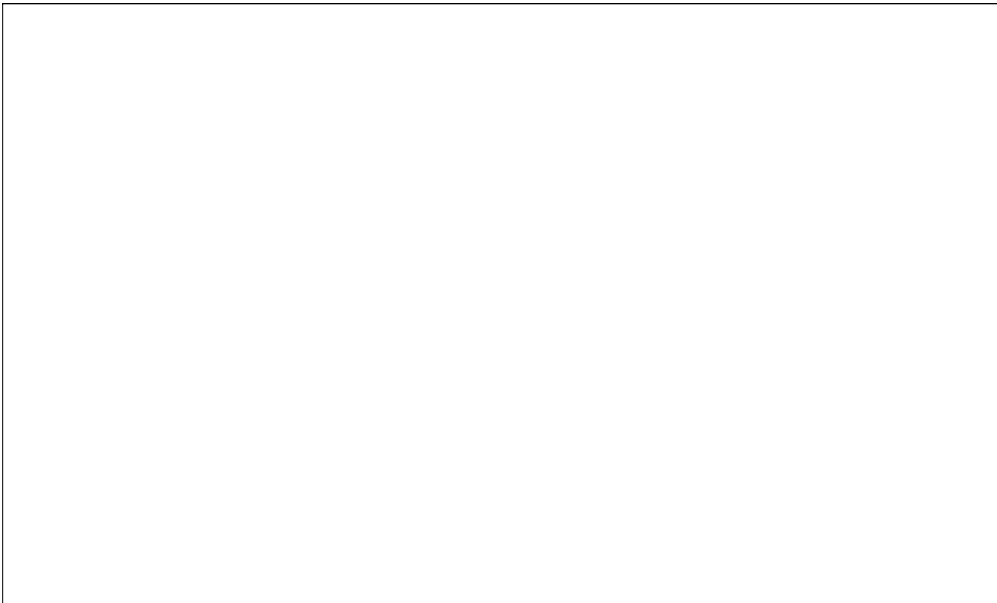
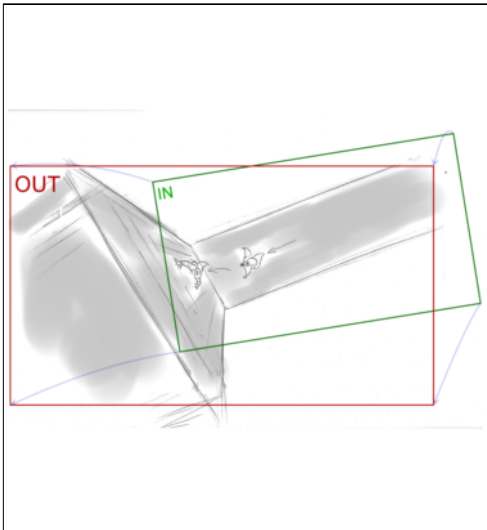

Seq	Scene	Panel
27	929	1

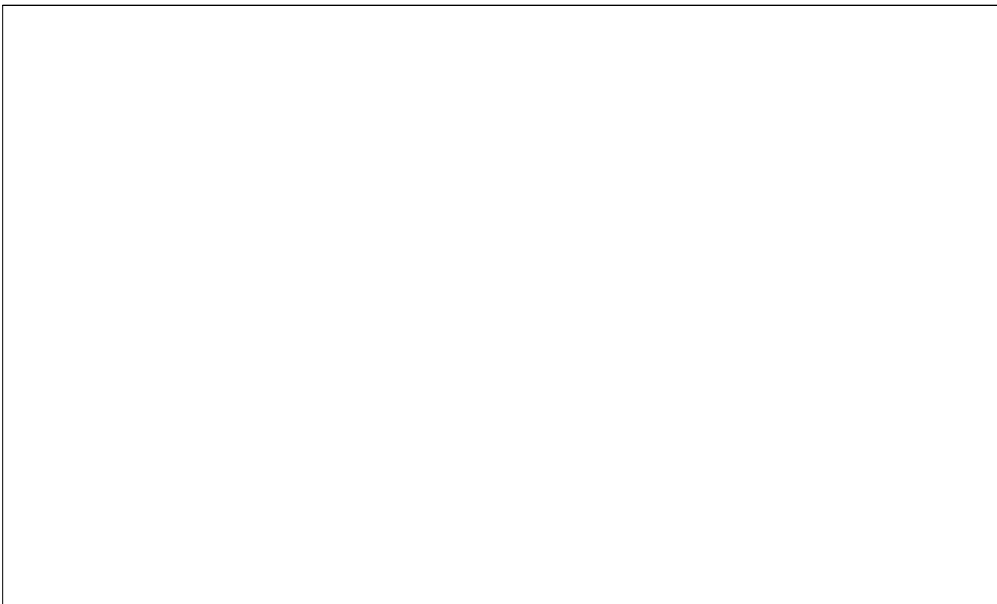
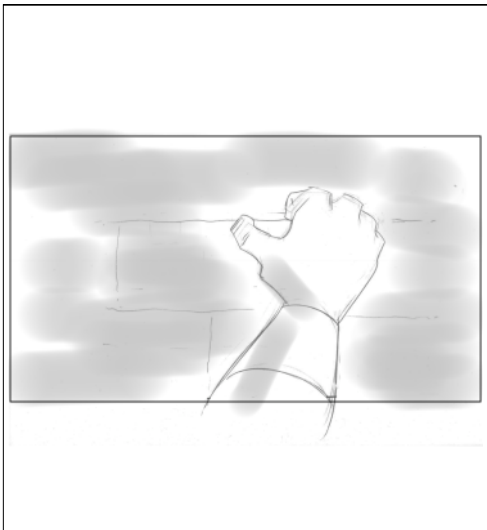

Seq	Scene	Panel
27	929	2

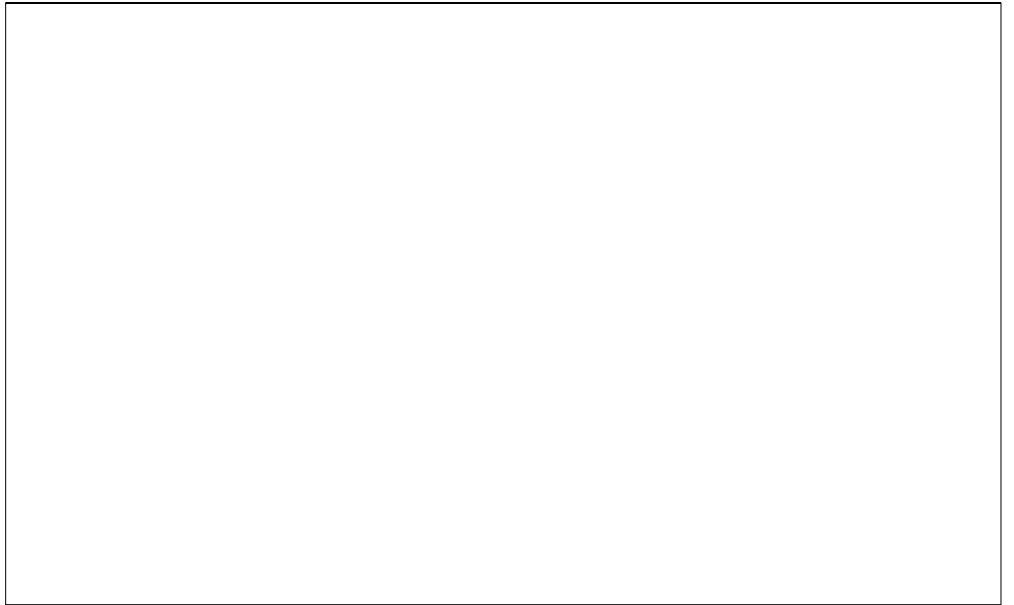
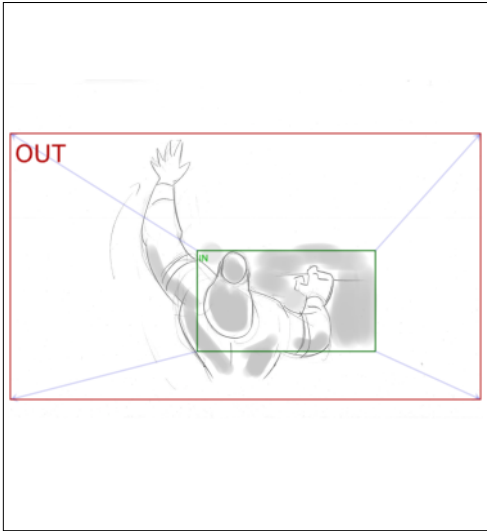

Seq	Scene	Panel
27	929	3

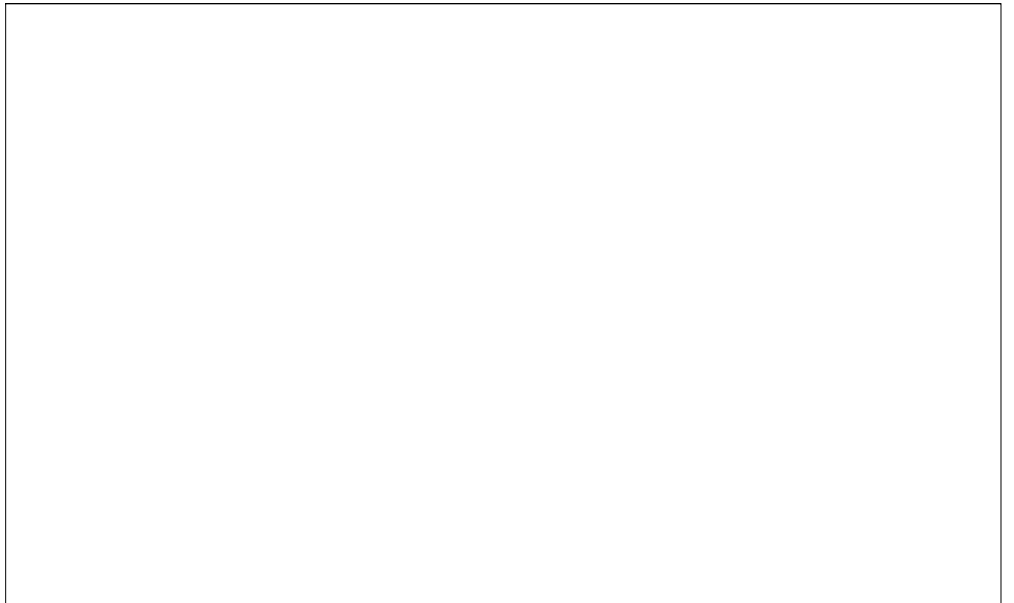
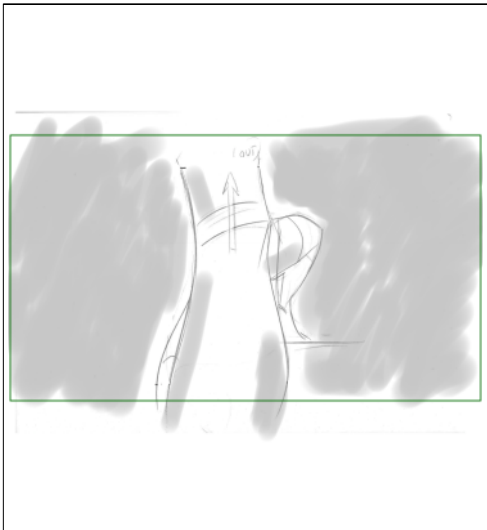

Seq	Scene	Panel
27	930	1

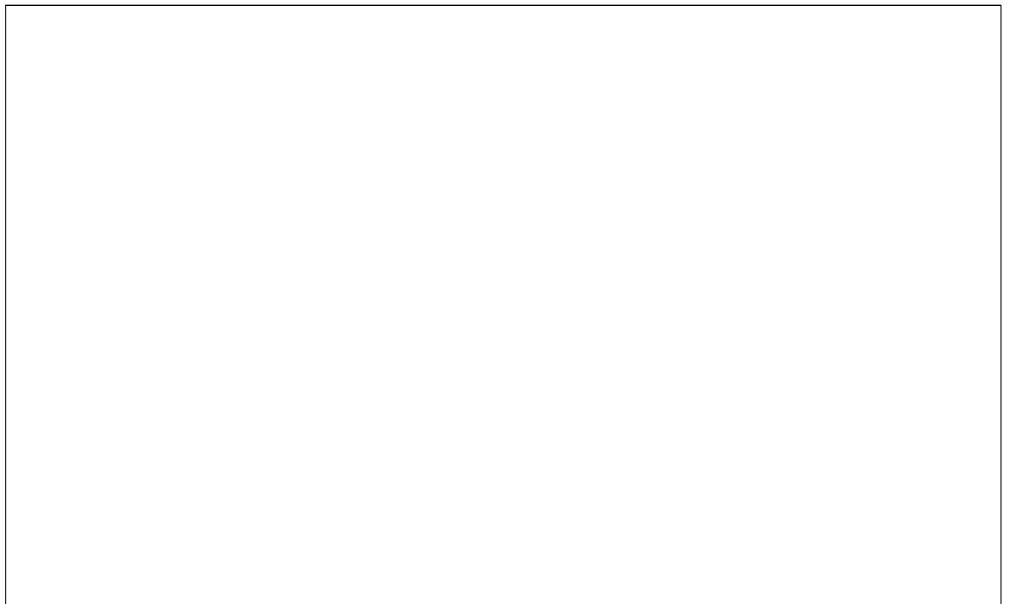
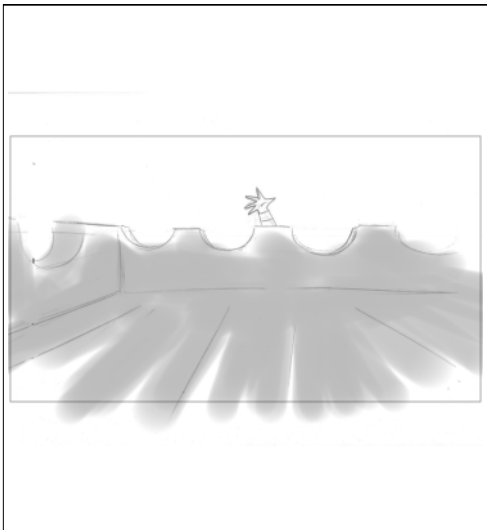

Seq	Scene	Panel
27	930	2

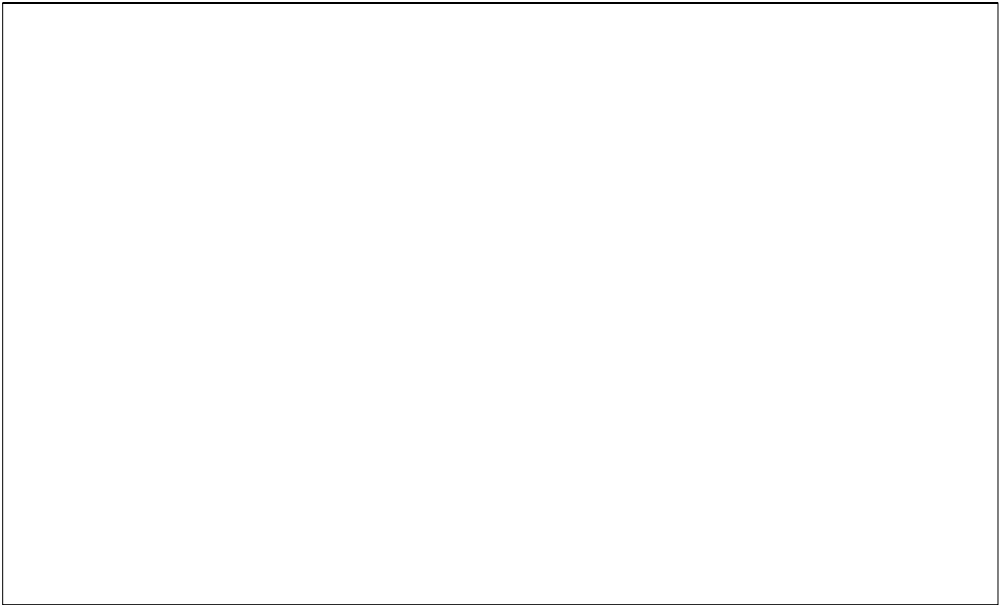
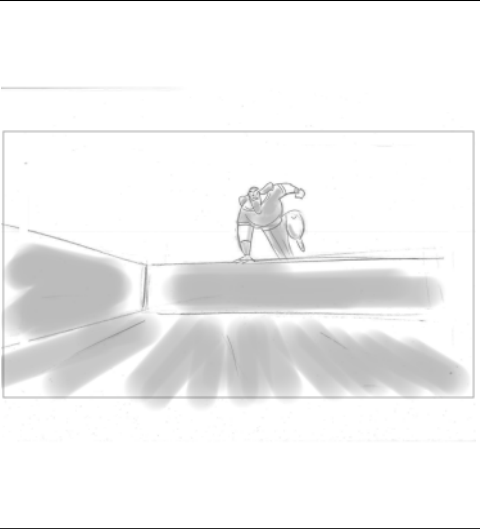

Seq	Scene	Panel
27	930	3

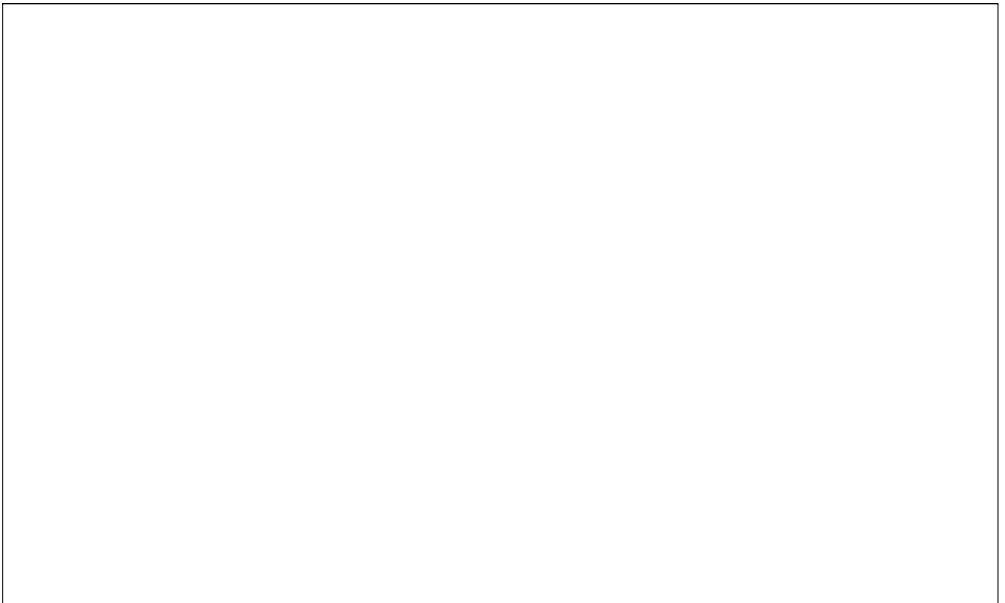

Seq	Scene	Panel
27	931	1

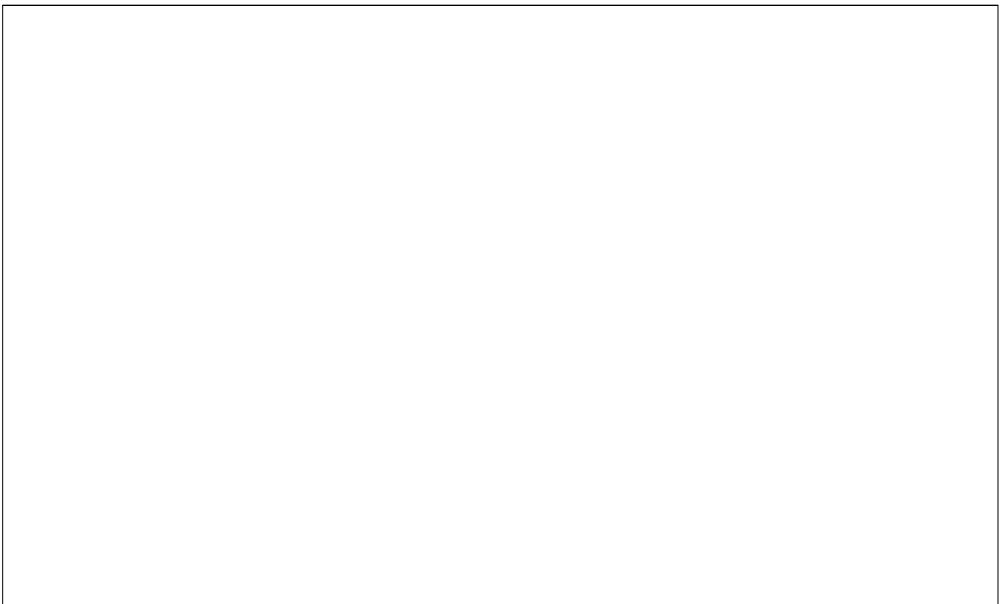

Seq	Scene	Panel
27	931	2

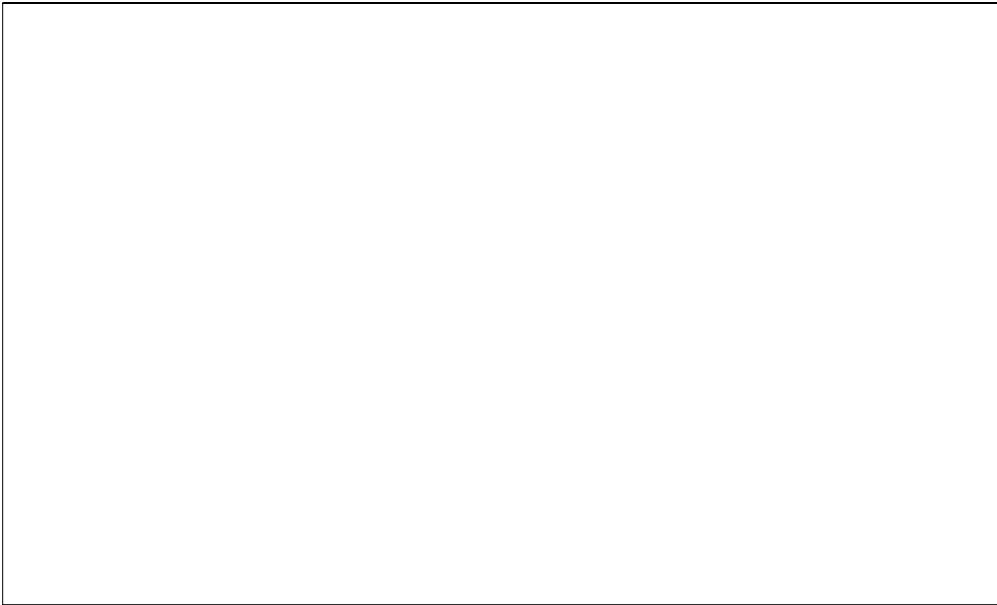

Seq	Scene	Panel
27	932	1

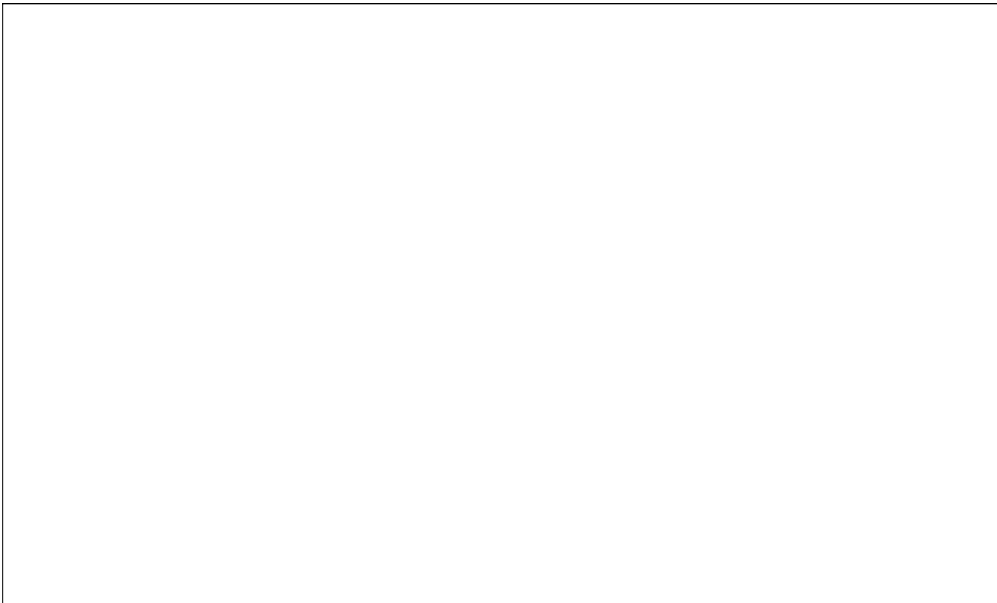
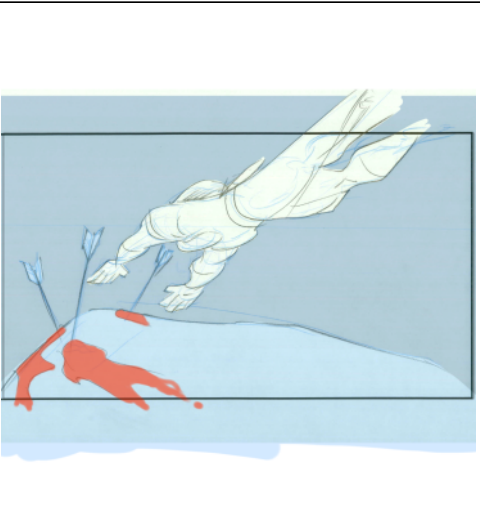

Seq	Scene	Panel
27	932	2

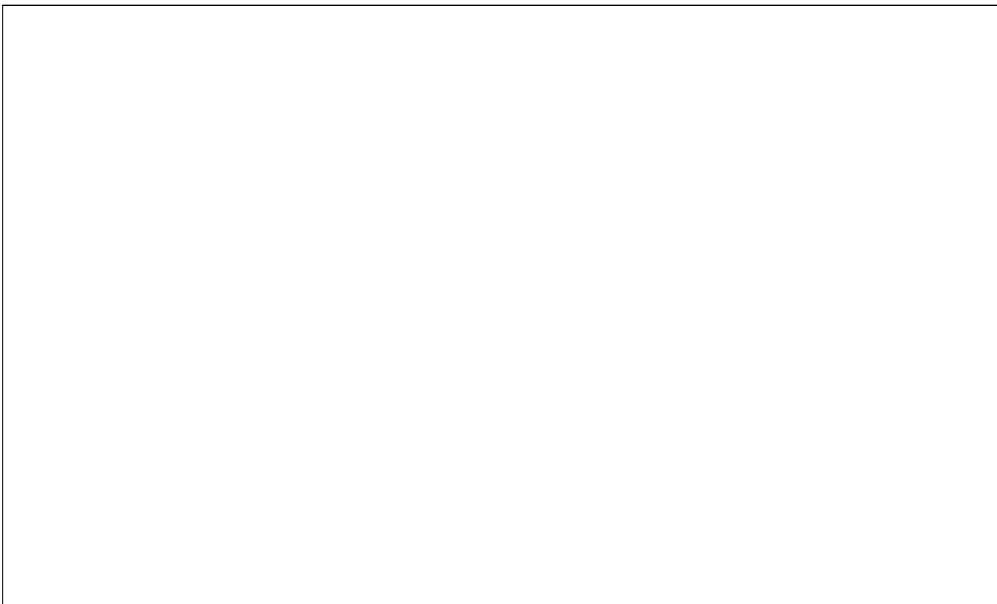
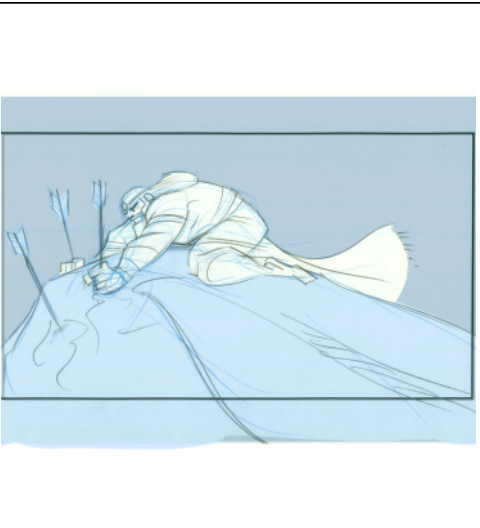

Seq	Scene	Panel
27	933	1

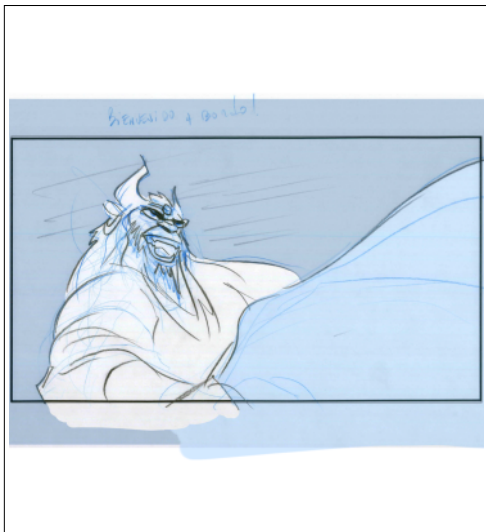

Dialog

ENKIDU:

"PARECE QUE NOS CONVERTIMOS EN PERSONAS IMPORTANTES!"

Seq	Scene	Panel
27	934	1

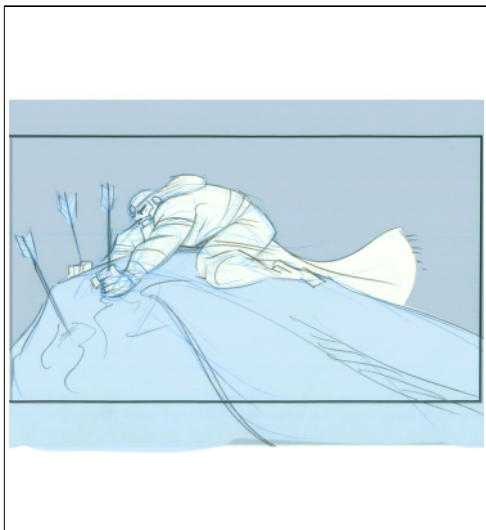

Dialog

GILGAMESH:

"SI! HASTA GANAMOS ENEMIGOS EN LOS CIELOS!"

Seq	Scene	Panel
27	935	1

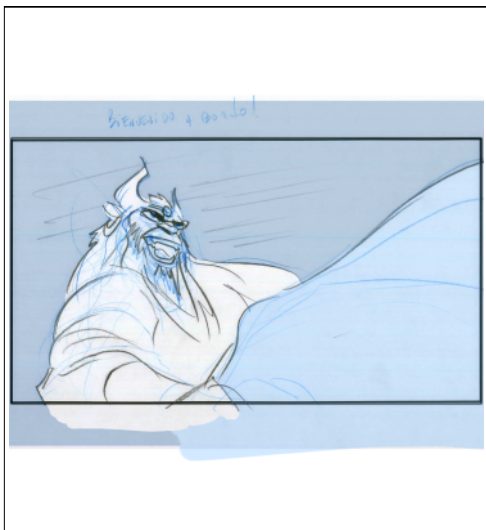

Seq	Scene	Panel
27	935	2

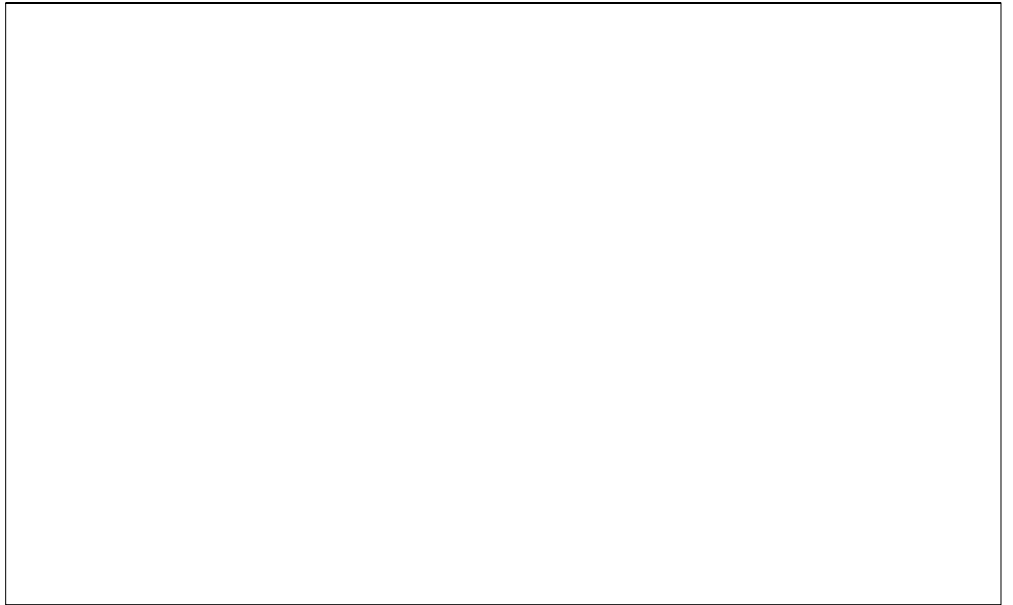
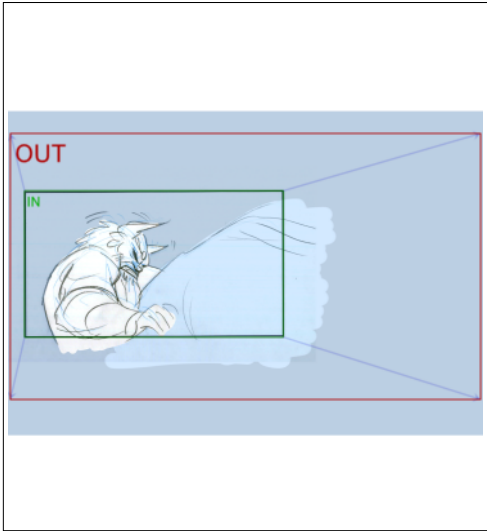

Seq	Scene	Panel
27	935	3

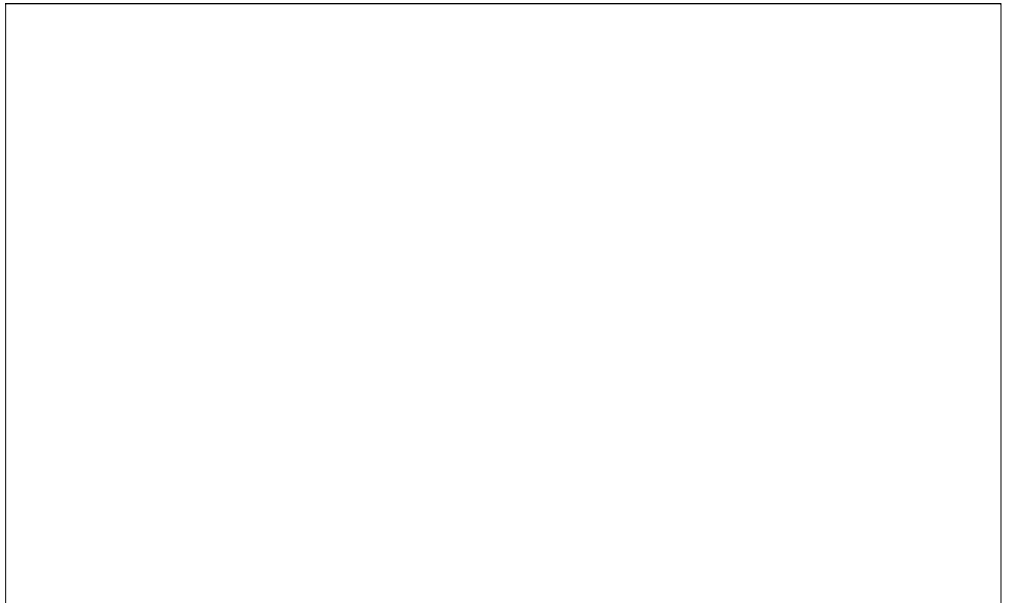
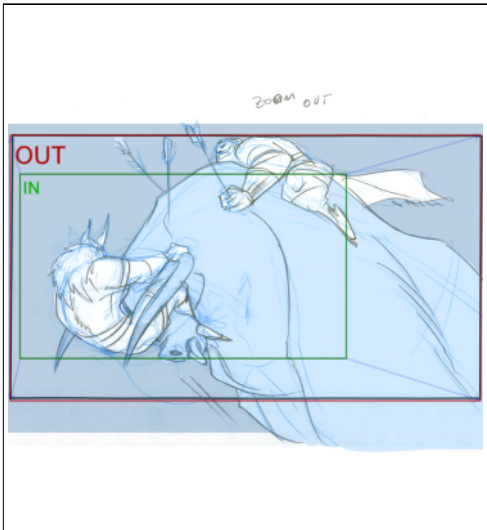

Seq	Scene	Panel
27	935	4

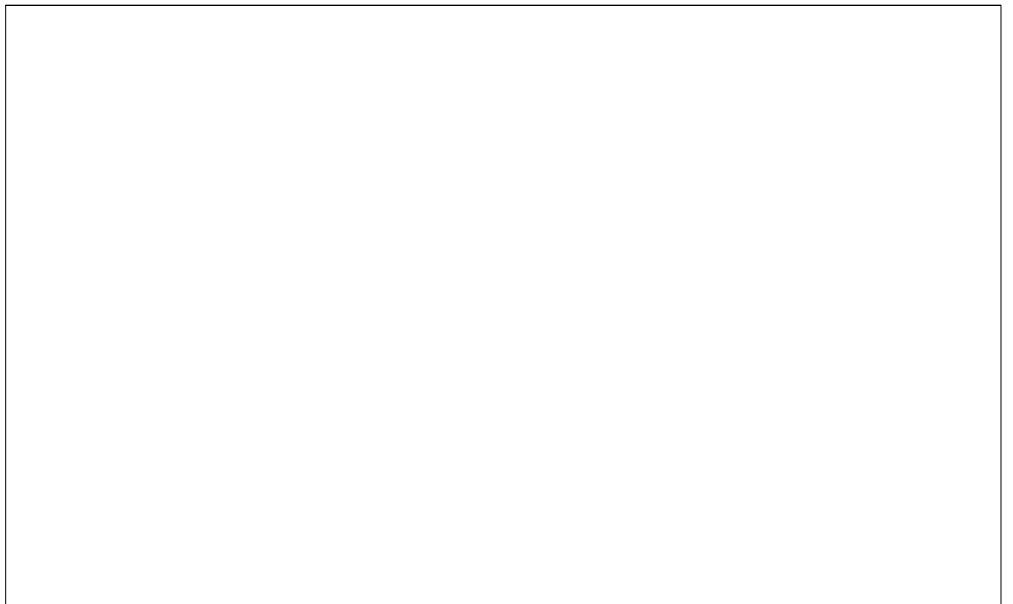
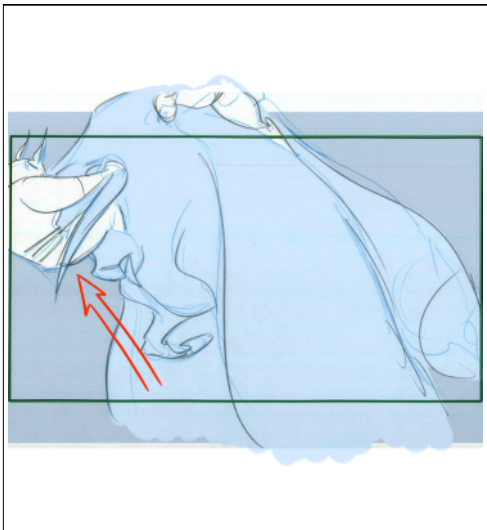

Seq	Scene	Panel
27	936	1

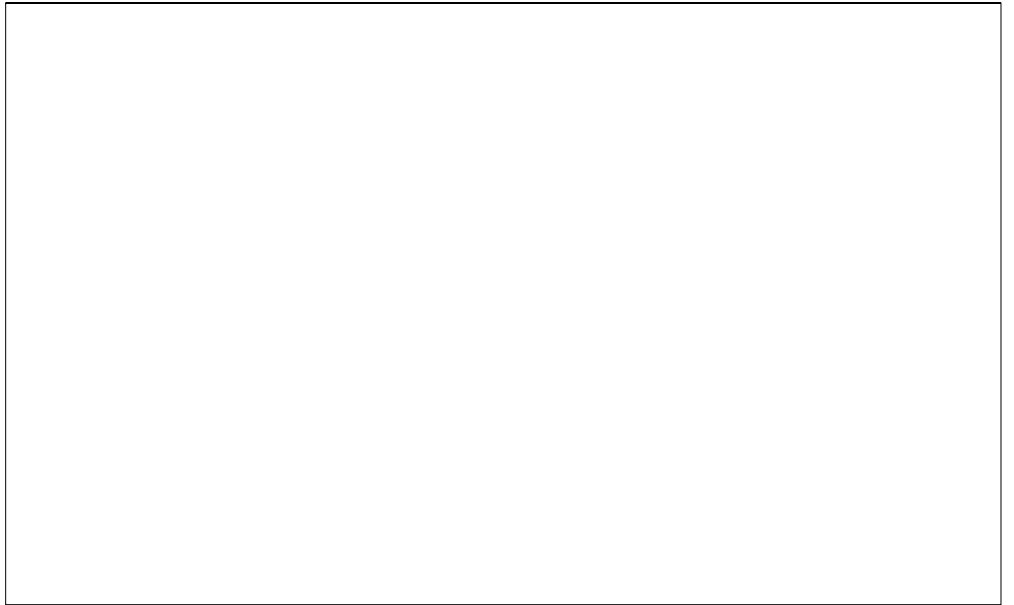
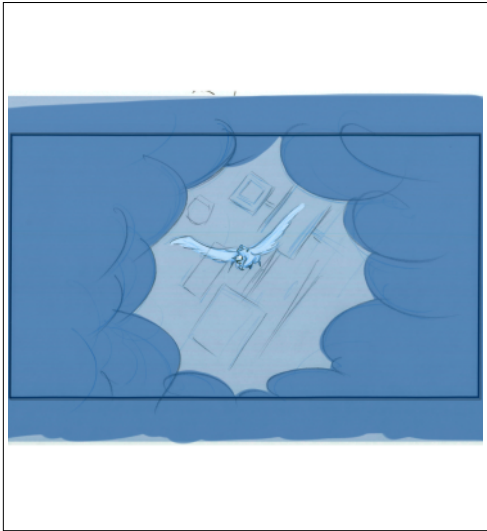

Seq	Scene	Panel
27	937	1

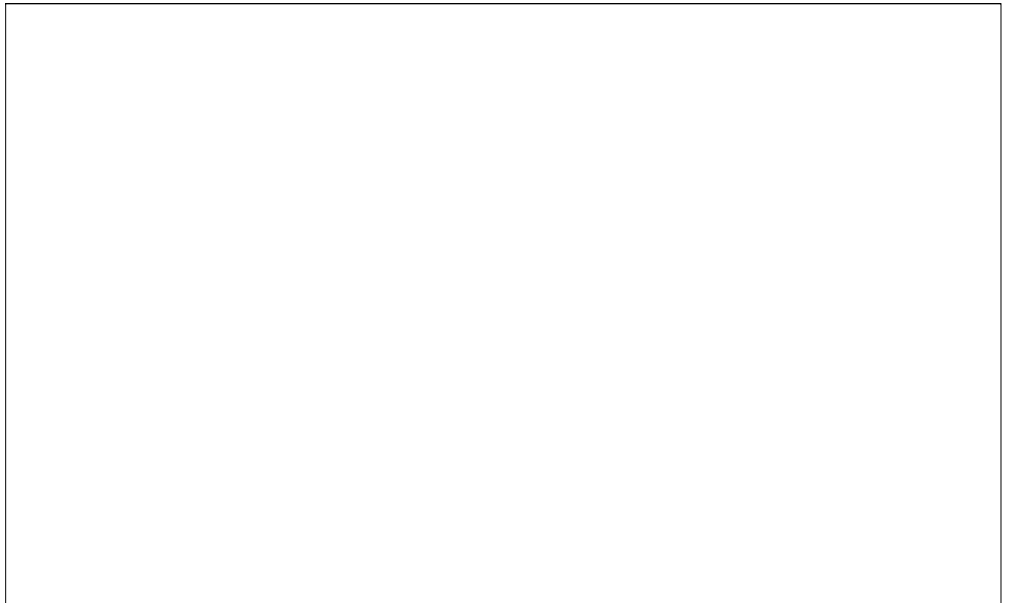
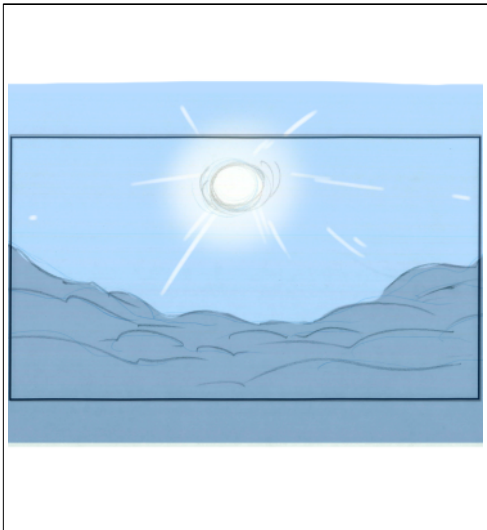

Seq	Scene	Panel
27	937	2

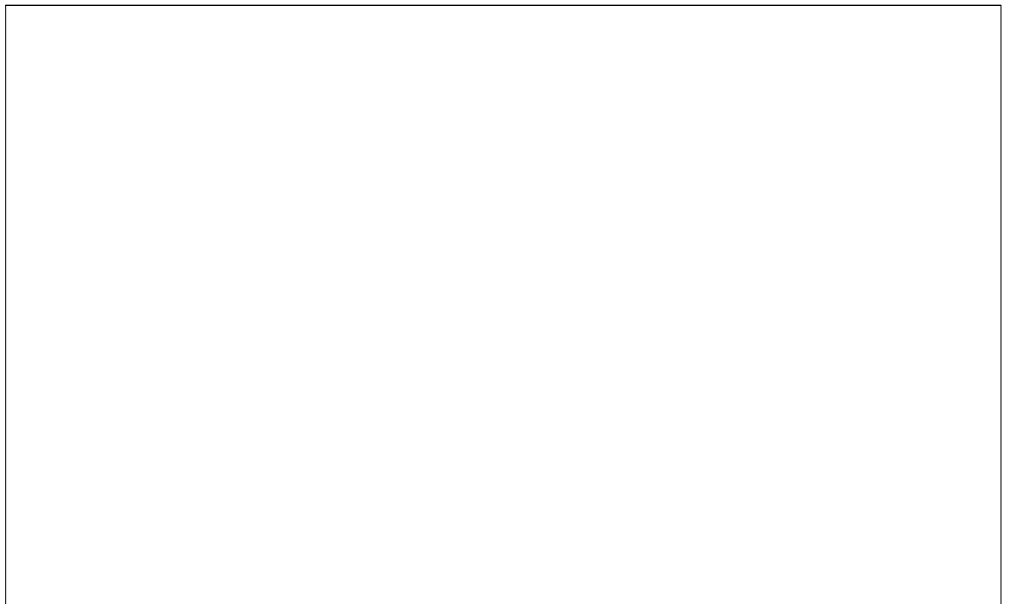
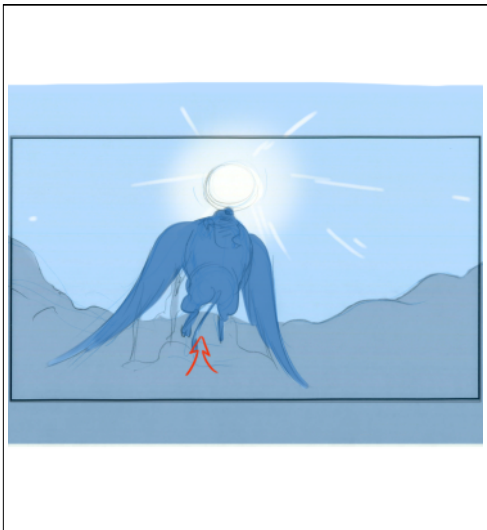

Seq	Scene	Panel
27	938	1

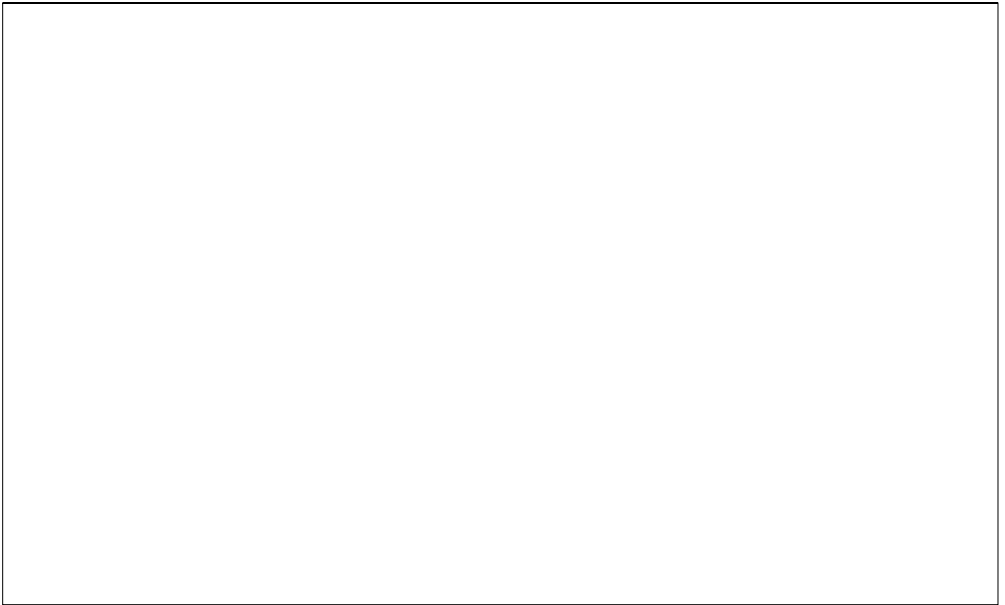

Seq	Scene	Panel
27	939	1

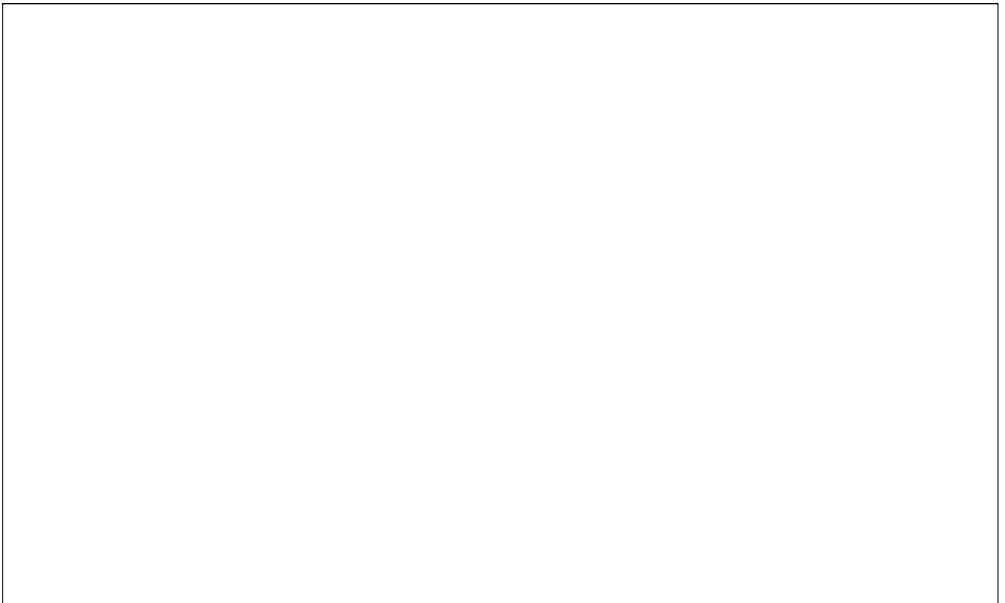
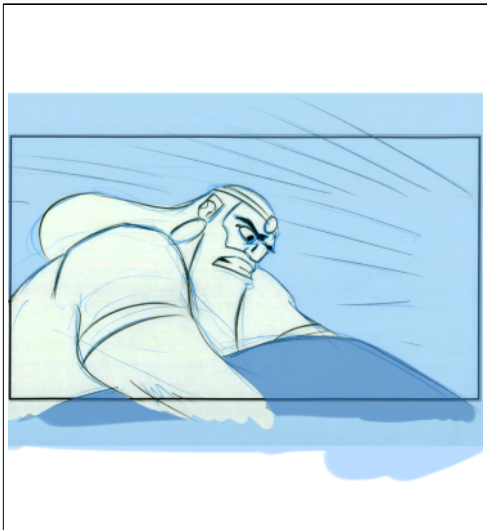

Seq	Scene	Panel
27	939	2

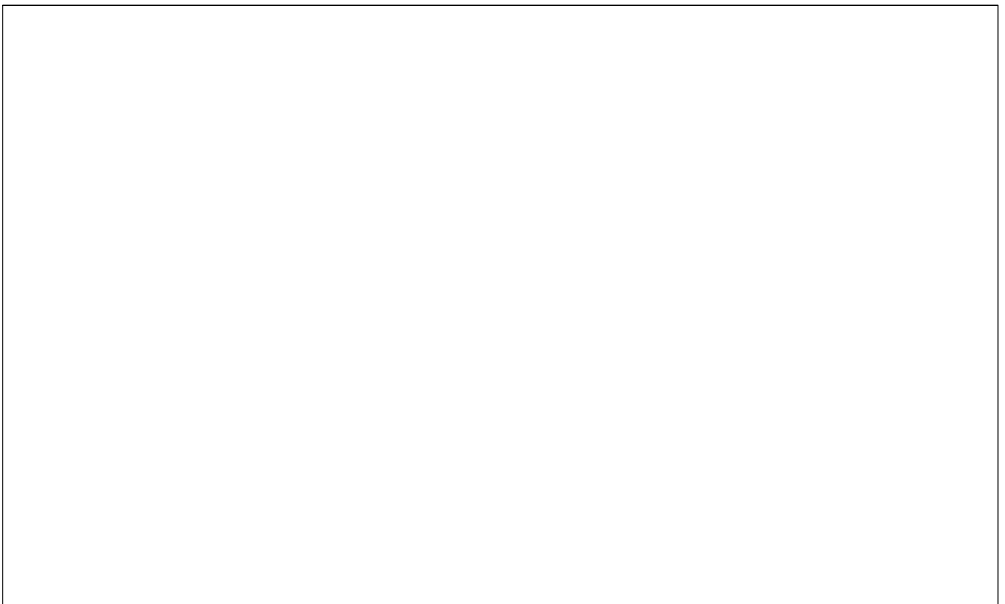
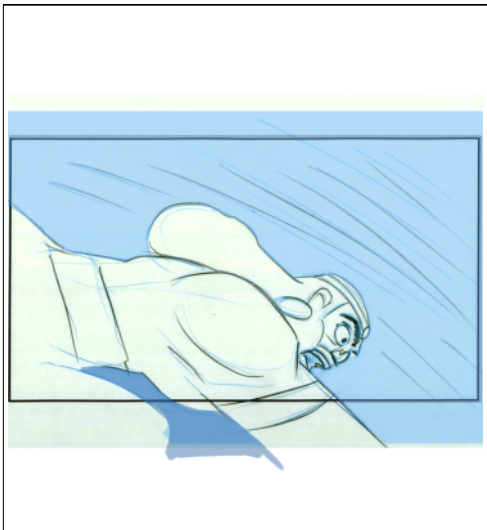

Seq	Scene	Panel
27	940	1

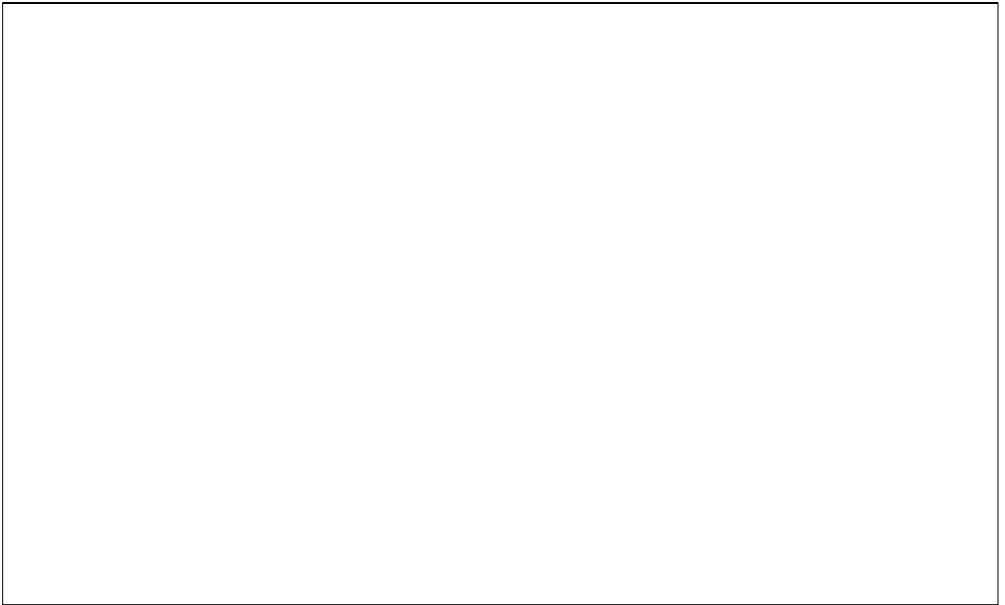
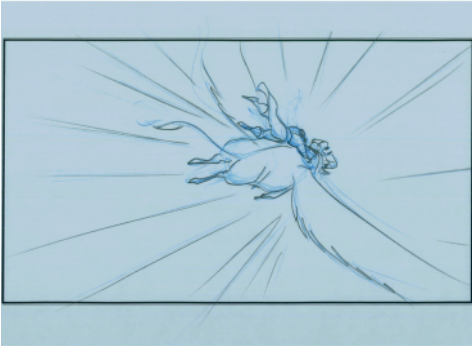

Seq	Scene	Panel
27	940	2

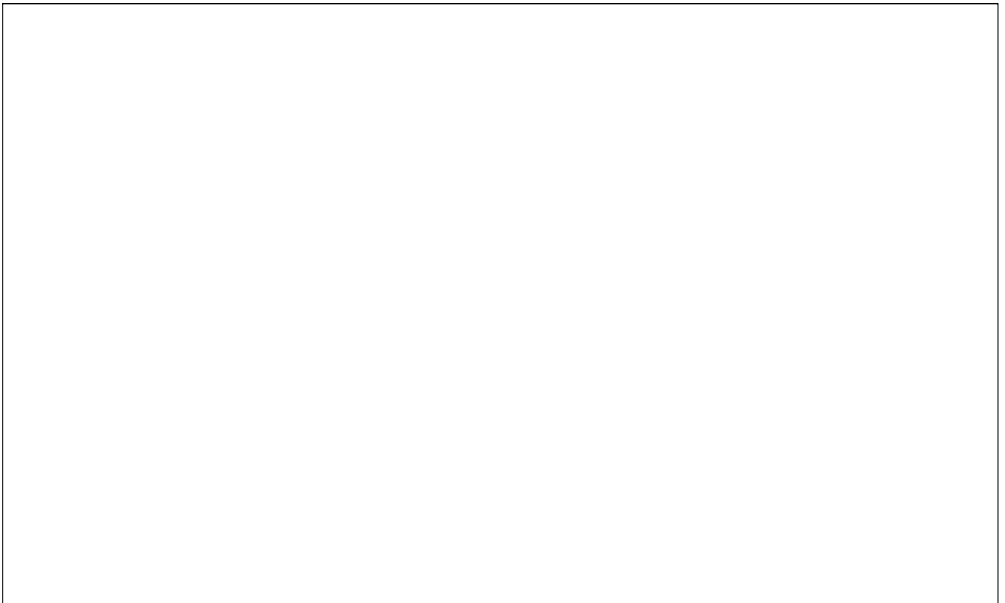
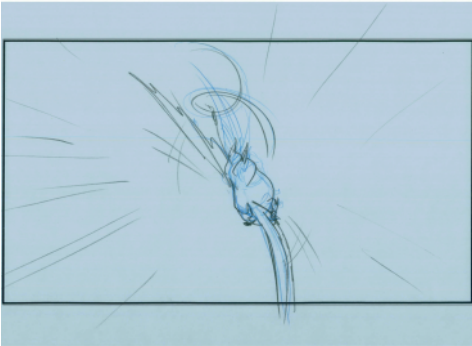

Seq	Scene	Panel
27	941	1

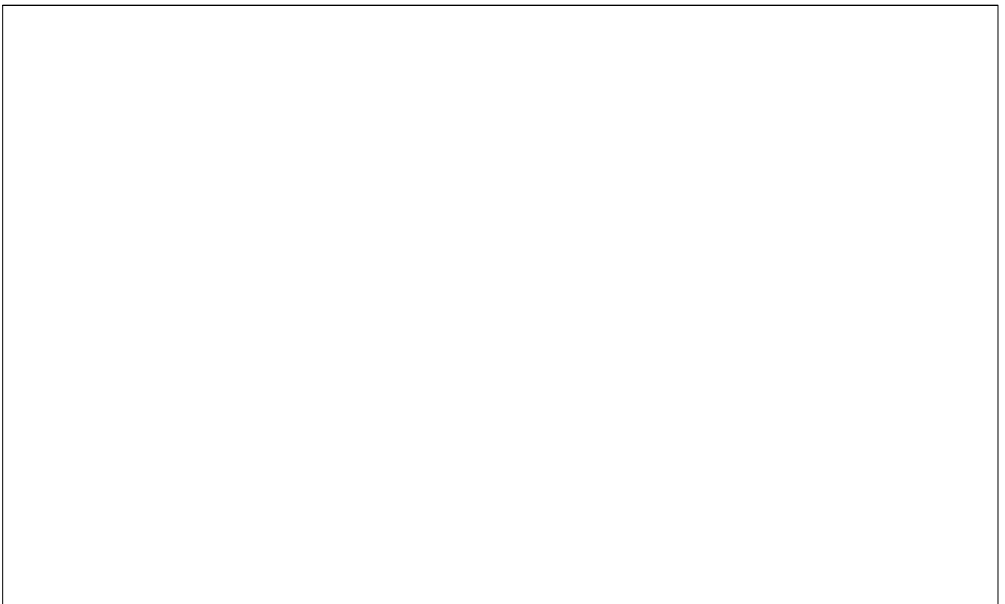
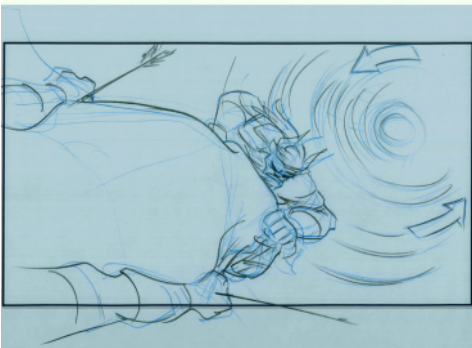

Seq	Scene	Panel
27	941	2

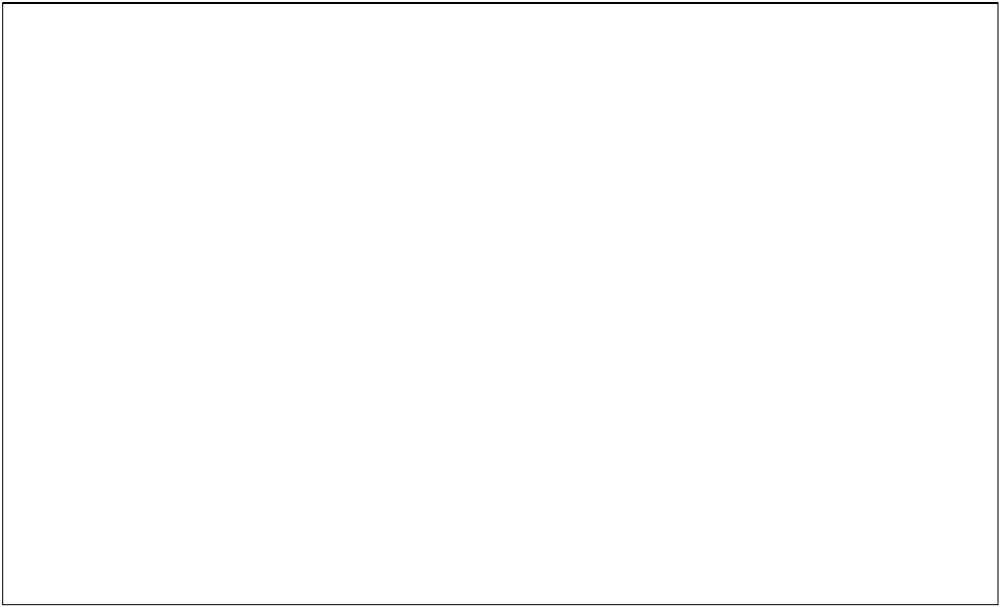
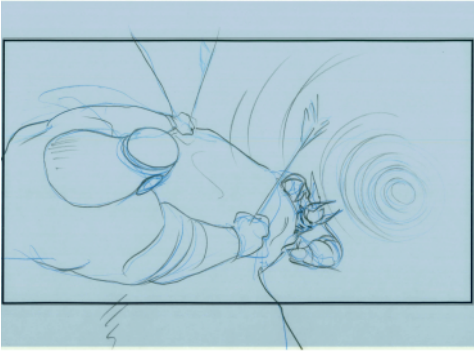

Seq	Scene	Panel
27	942	1

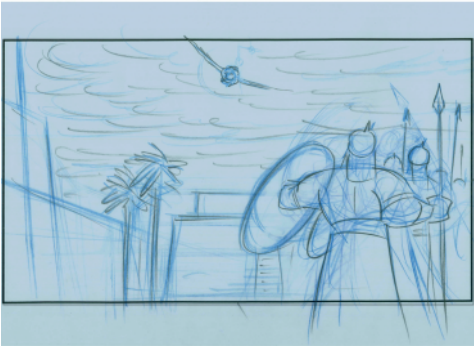

Seq	Scene	Panel
27	943	1

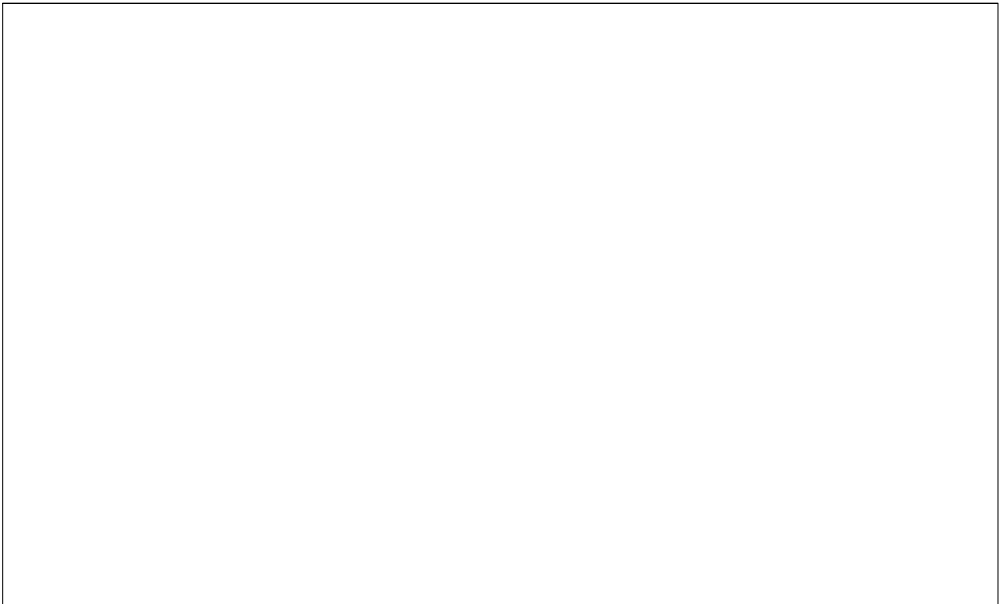
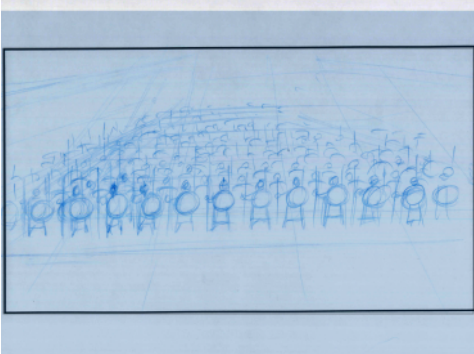

Seq	Scene	Panel
27	944	1

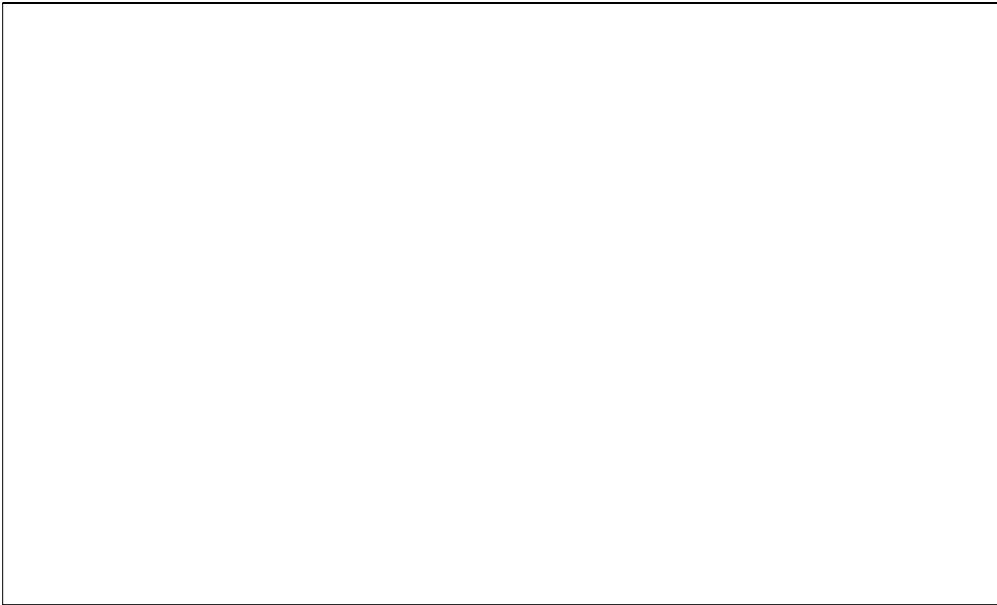
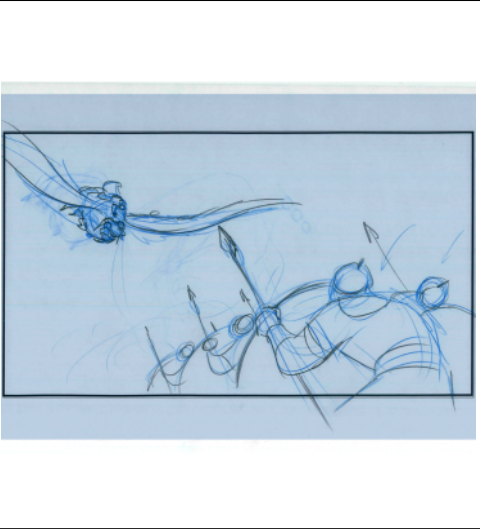

Seq	Scene	Panel
27	945	1

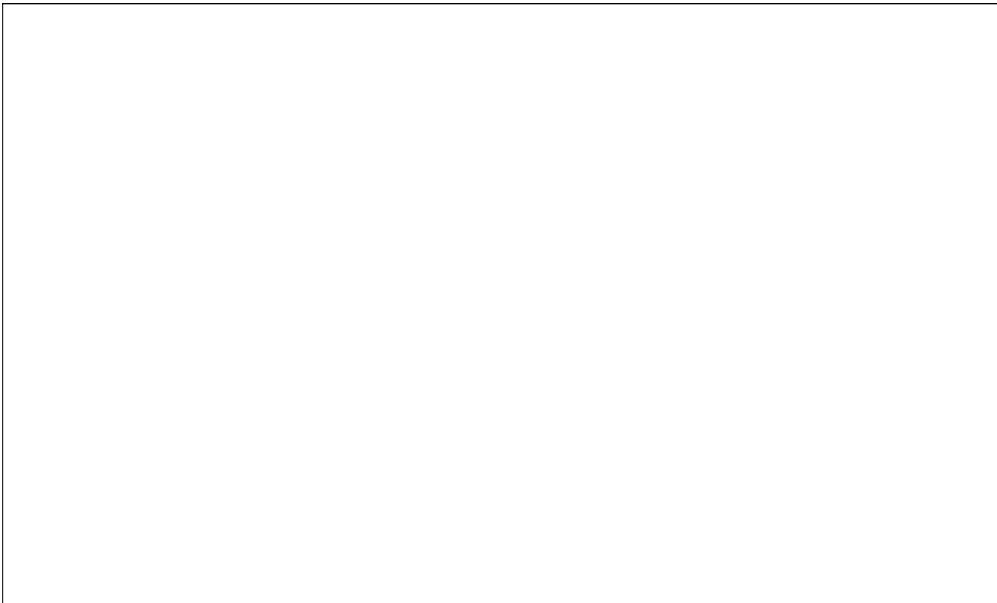
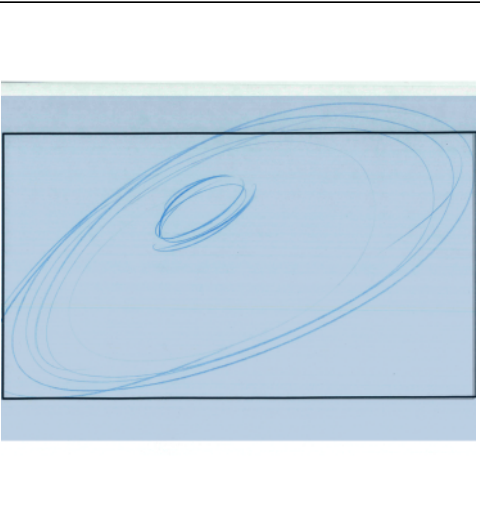

Seq	Scene	Panel
27	945	2

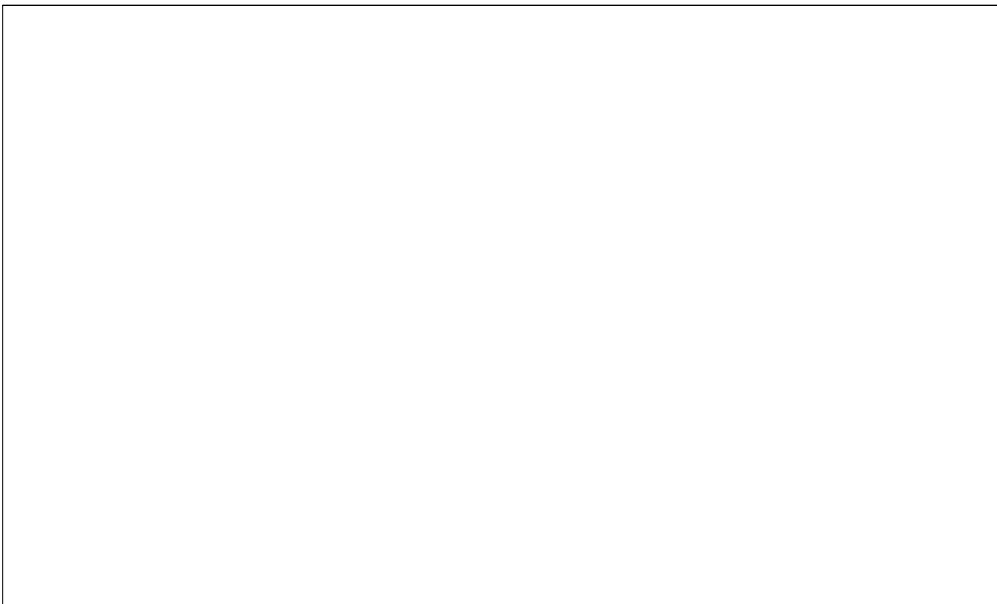
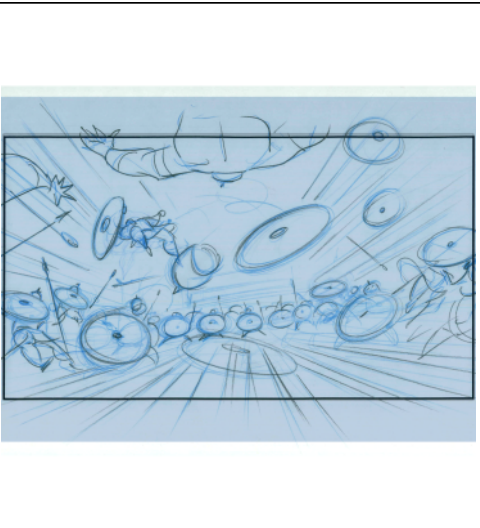

Seq	Scene	Panel
27	945	3

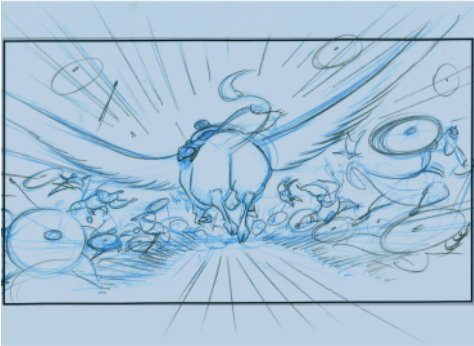

Seq	Scene	Panel
27	945	4

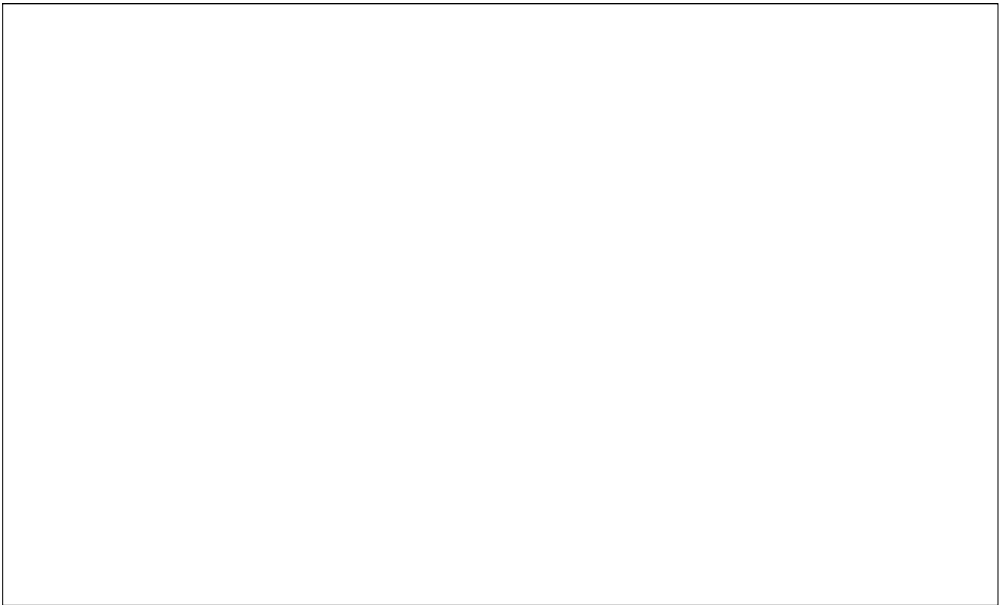
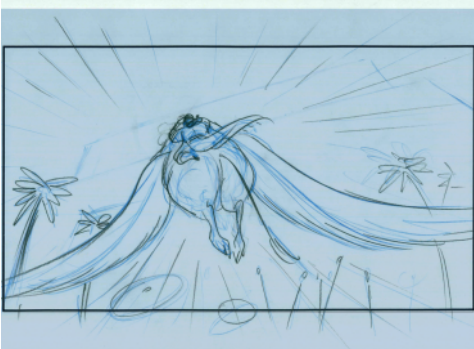

Seq	Scene	Panel
27	946	1

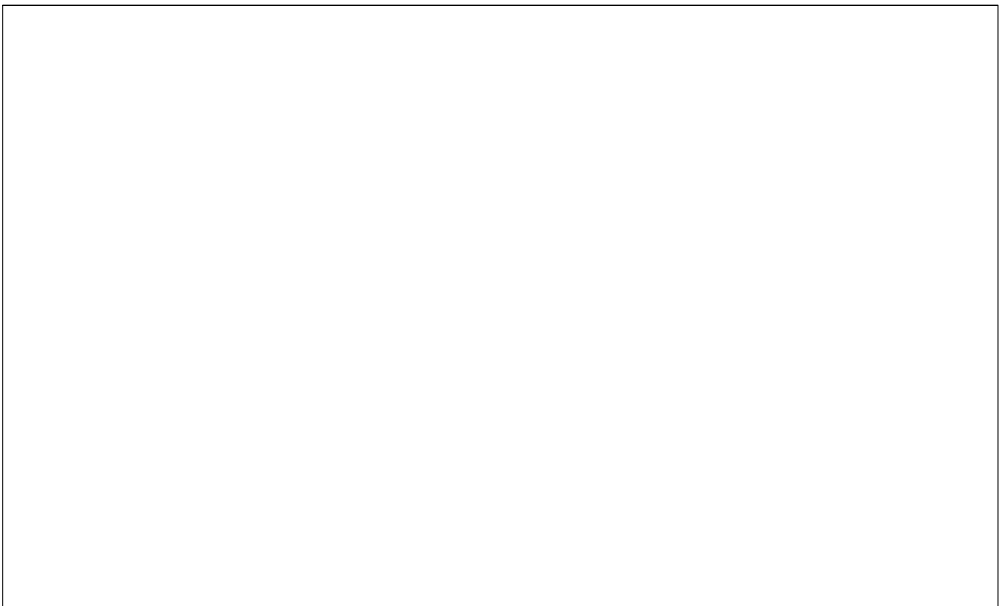
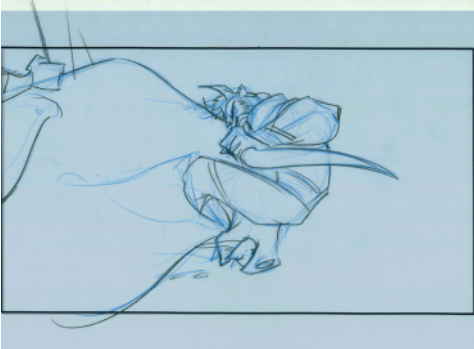

Seq	Scene	Panel
27	946	2

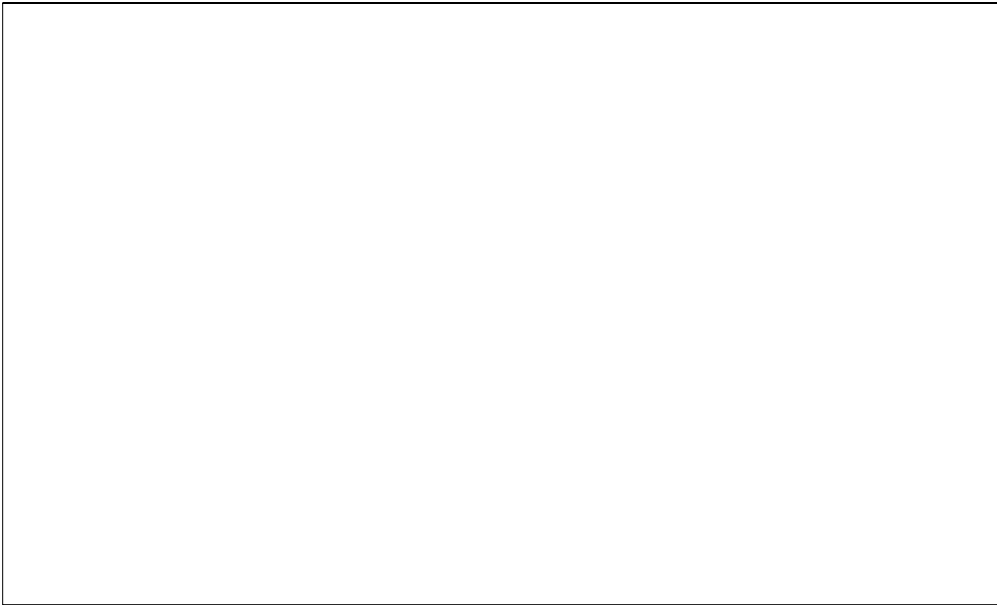
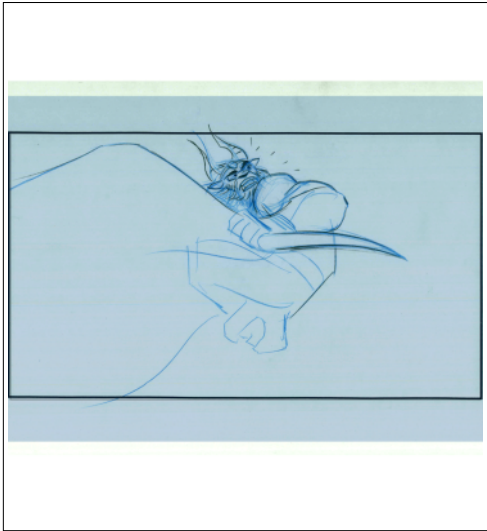

Seq	Scene	Panel
27	947	1

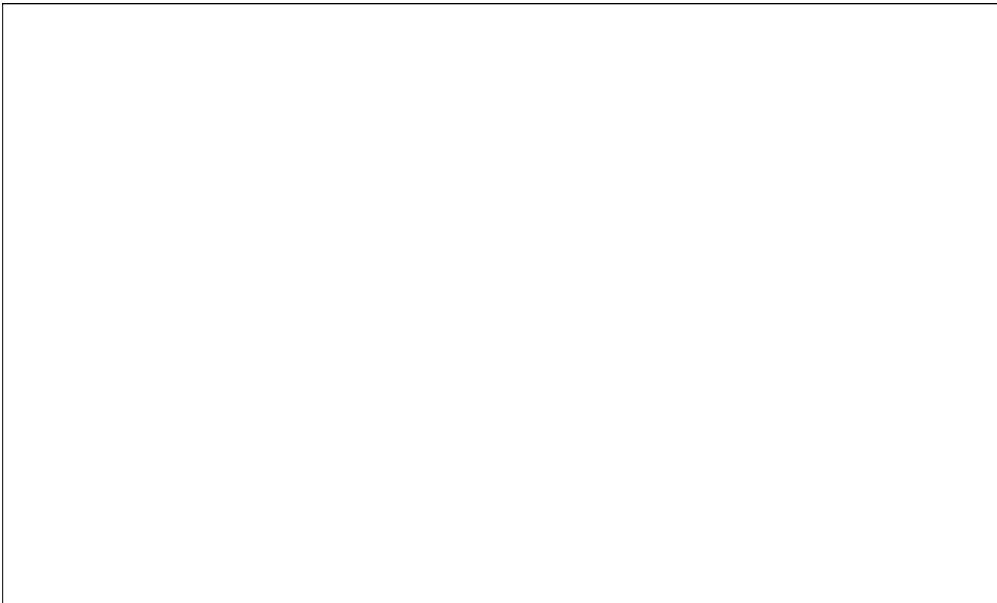
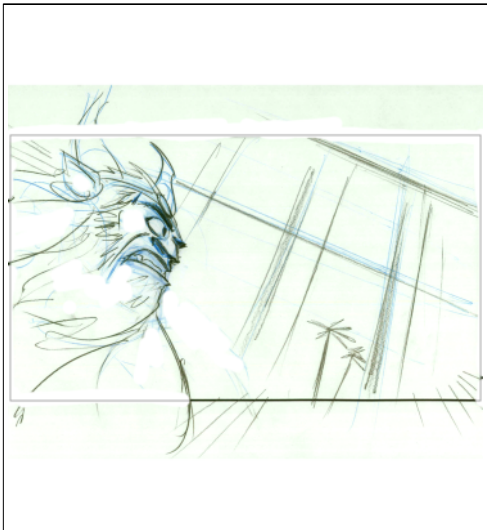

Seq	Scene	Panel
27	948	1

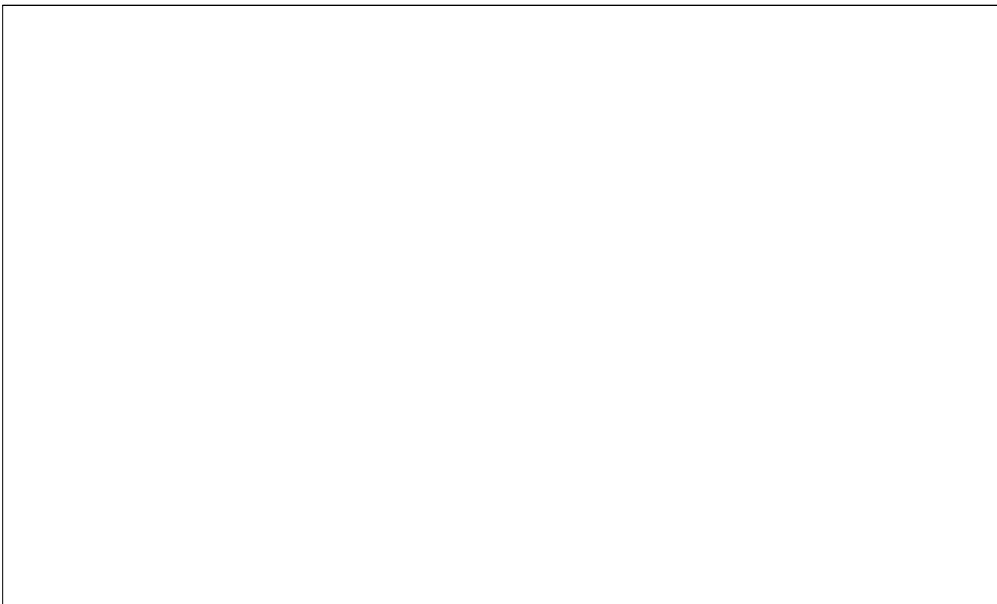

Seq	Scene	Panel
27	948	2

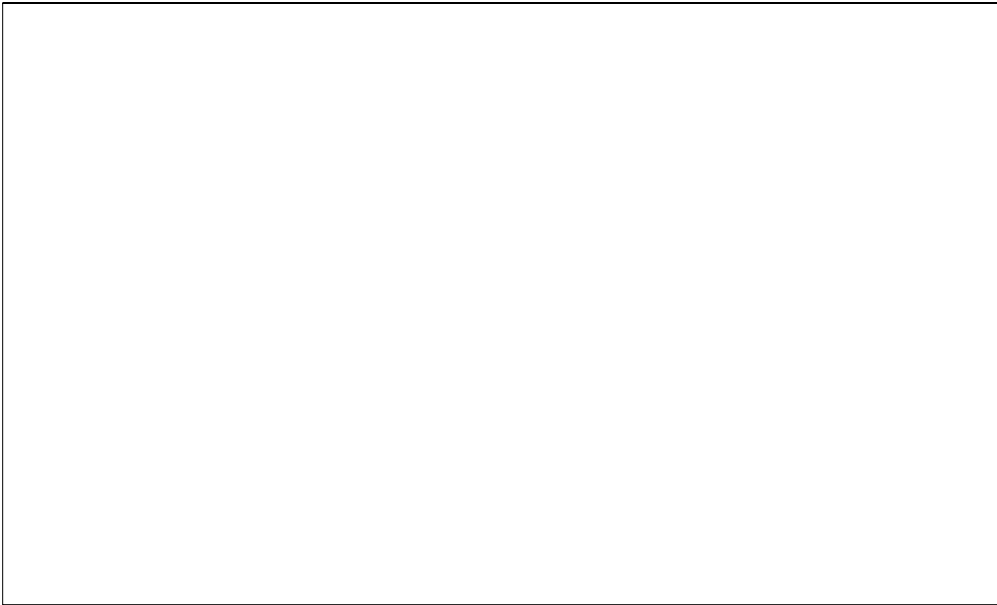
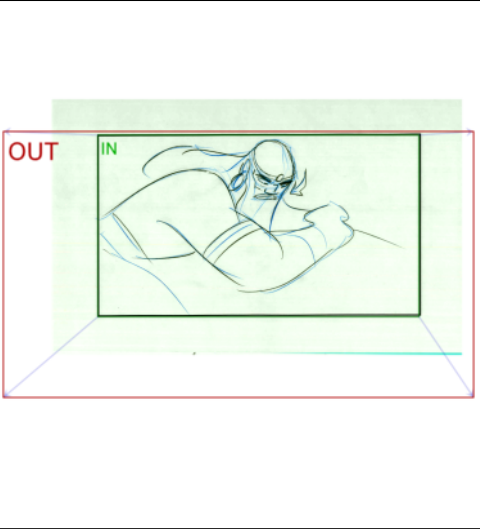

Seq	Scene	Panel
27	948	3

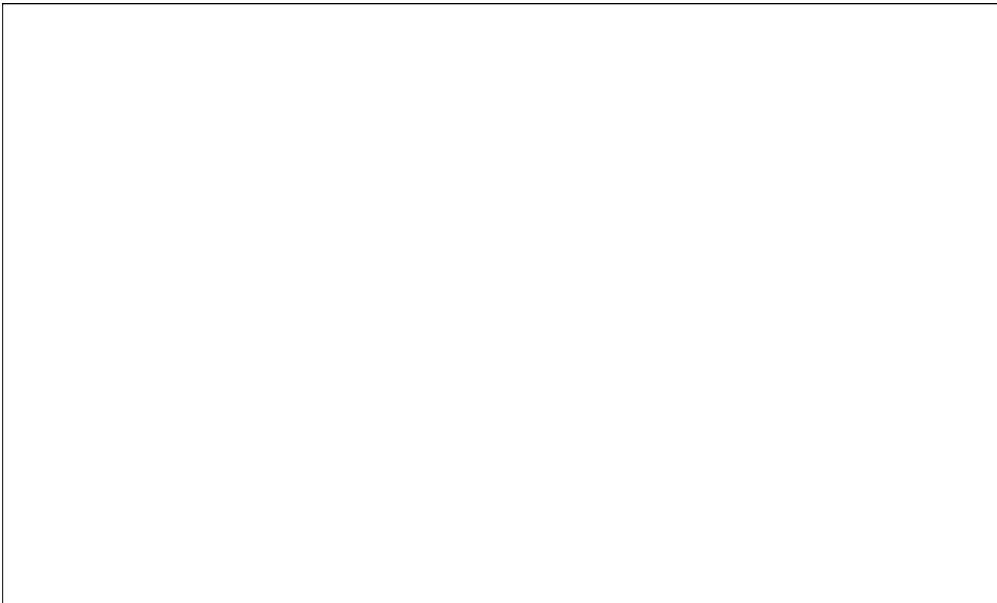
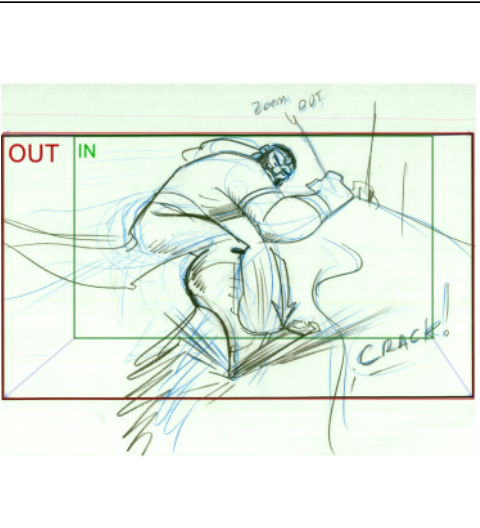

Seq	Scene	Panel
27	949	1

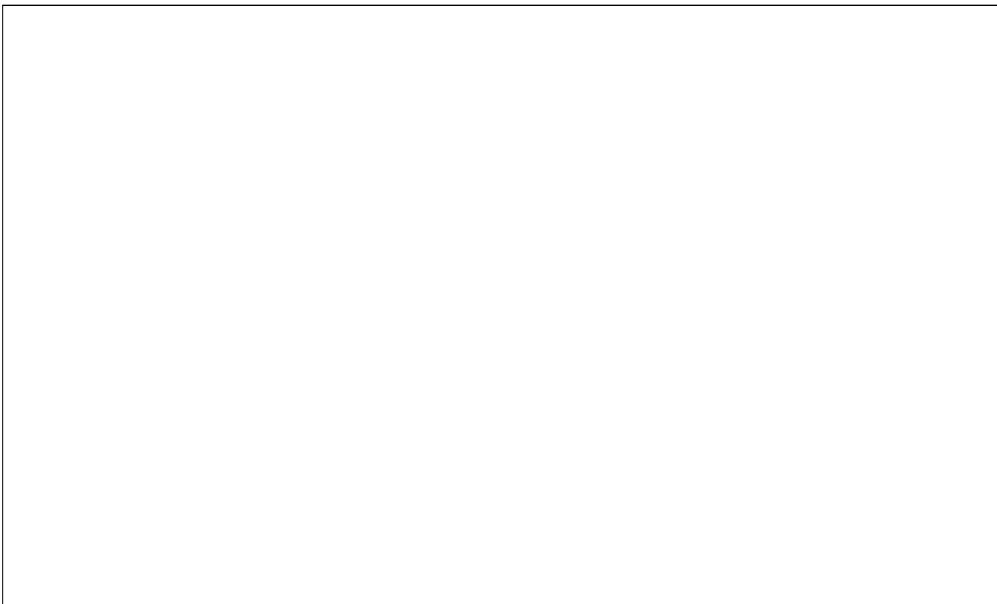
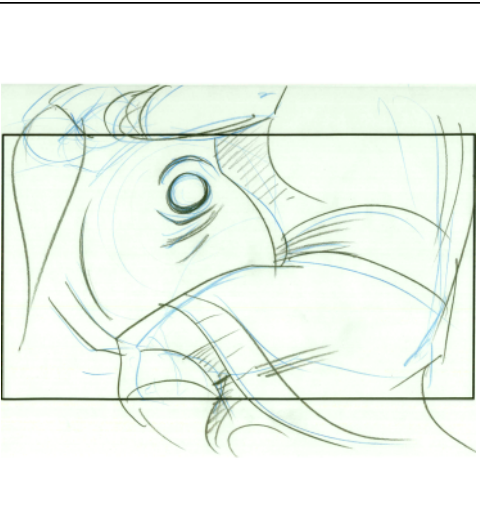

Seq	Scene	Panel
27	950	1

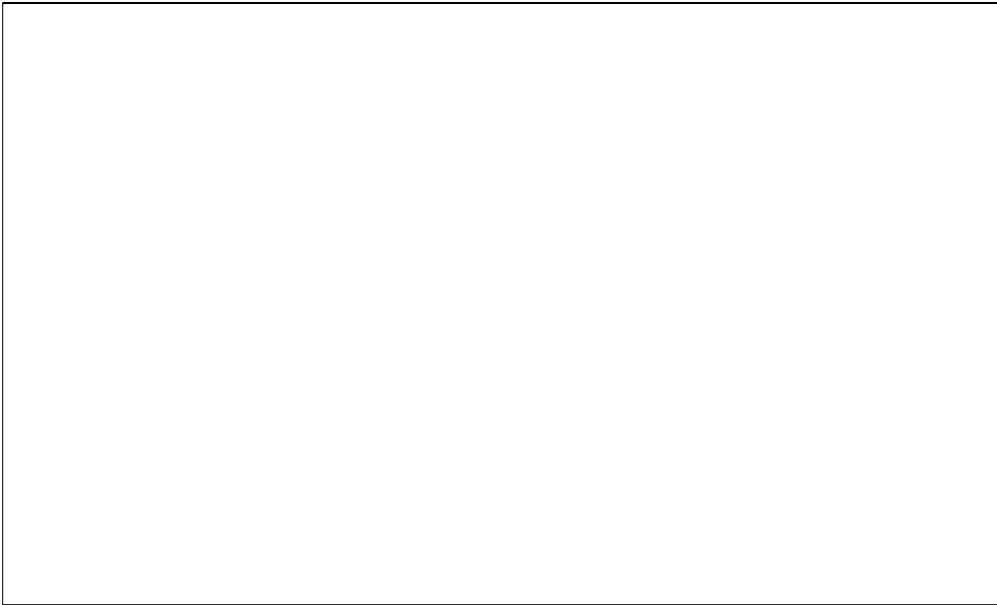
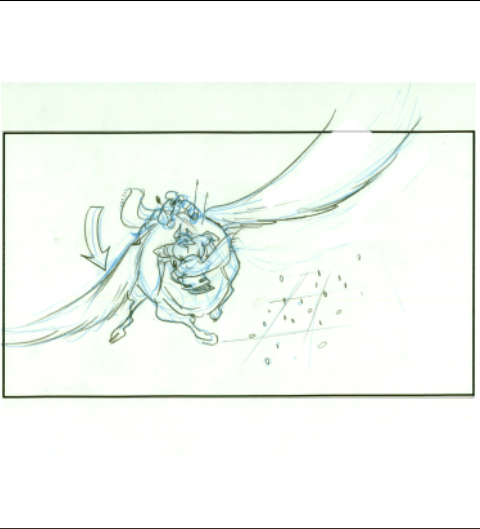

Seq	Scene	Panel
27	951	1

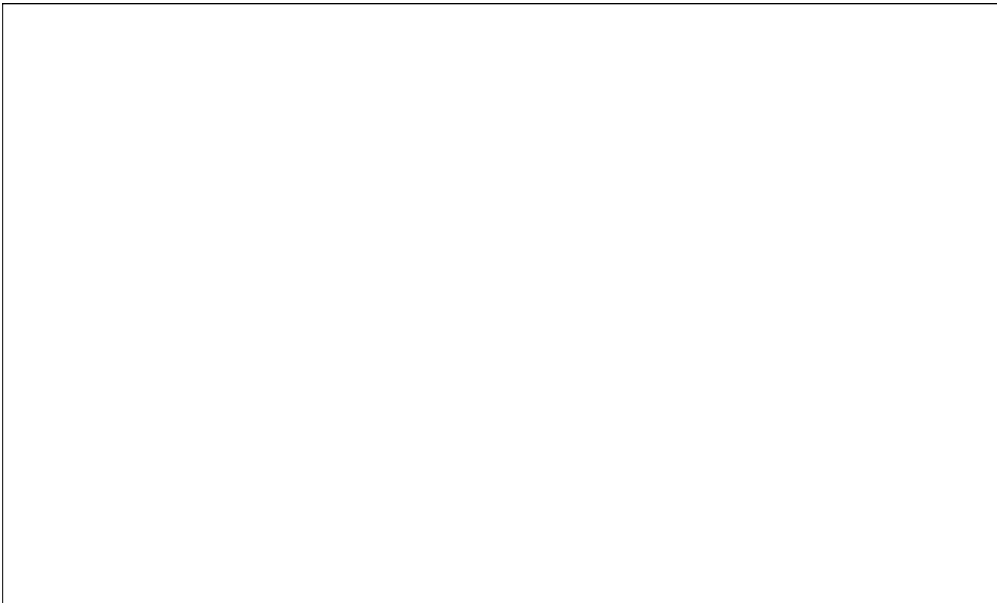
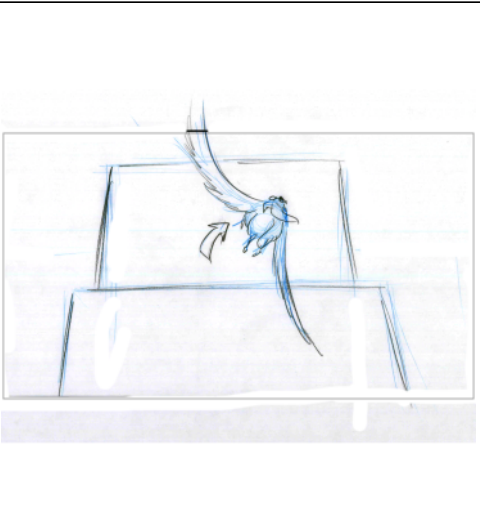

Seq	Scene	Panel
27	951	2

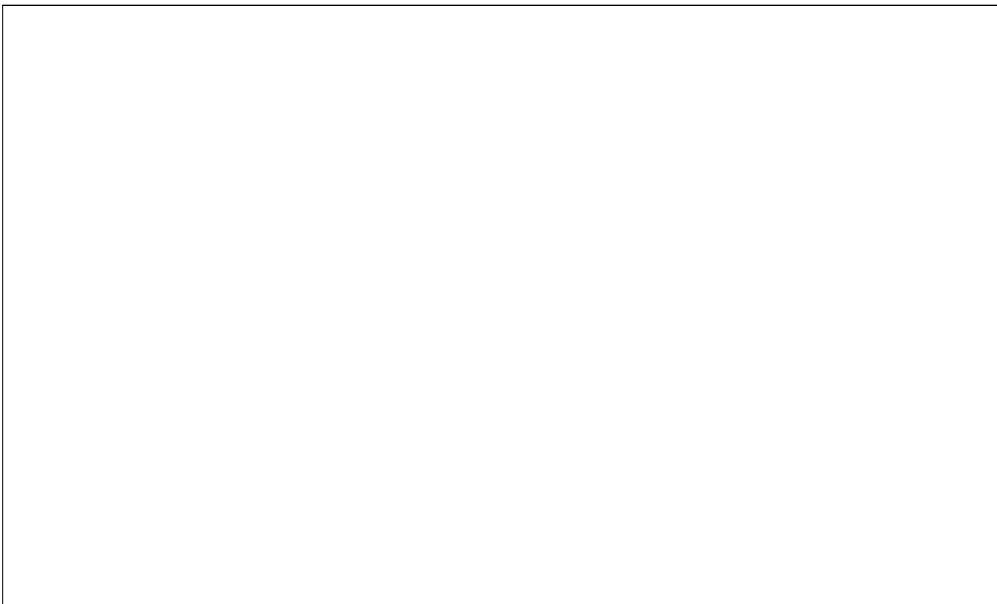
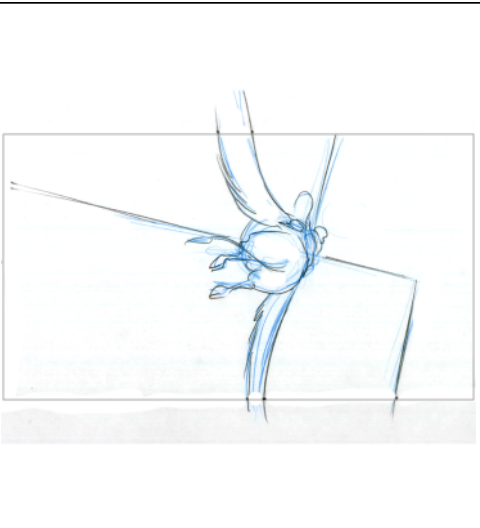

Seq	Scene	Panel
27	951	3

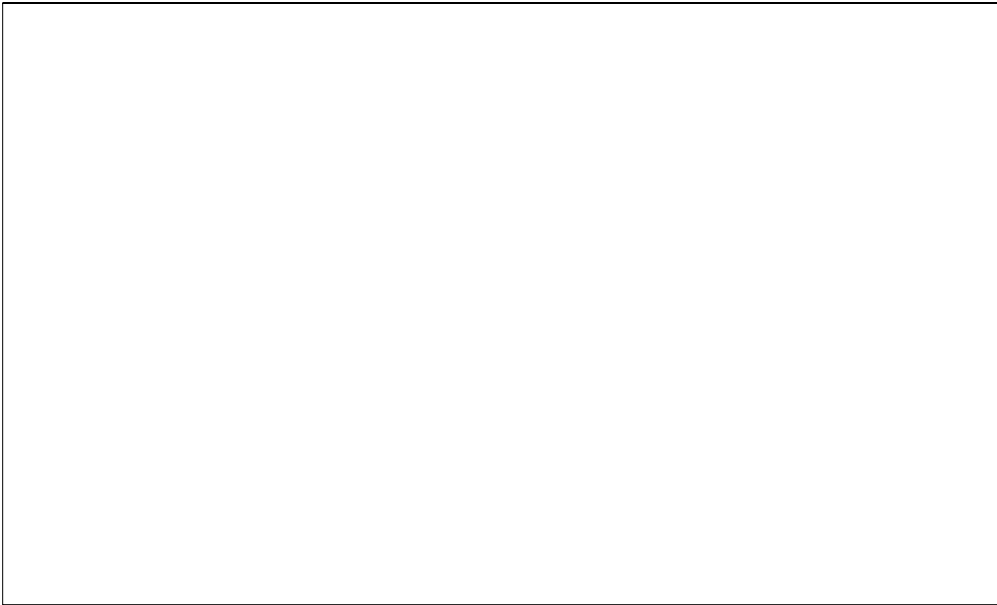
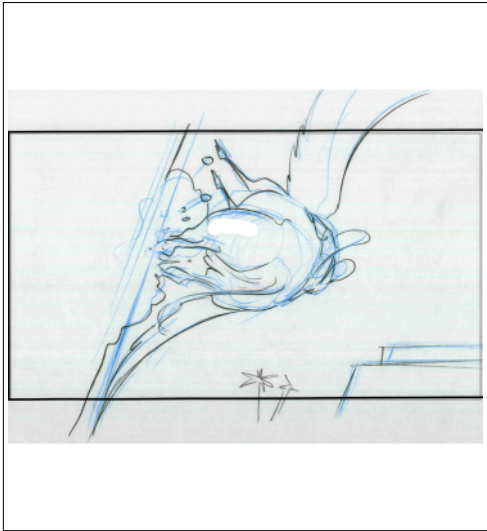

Seq	Scene	Panel
27	951	4

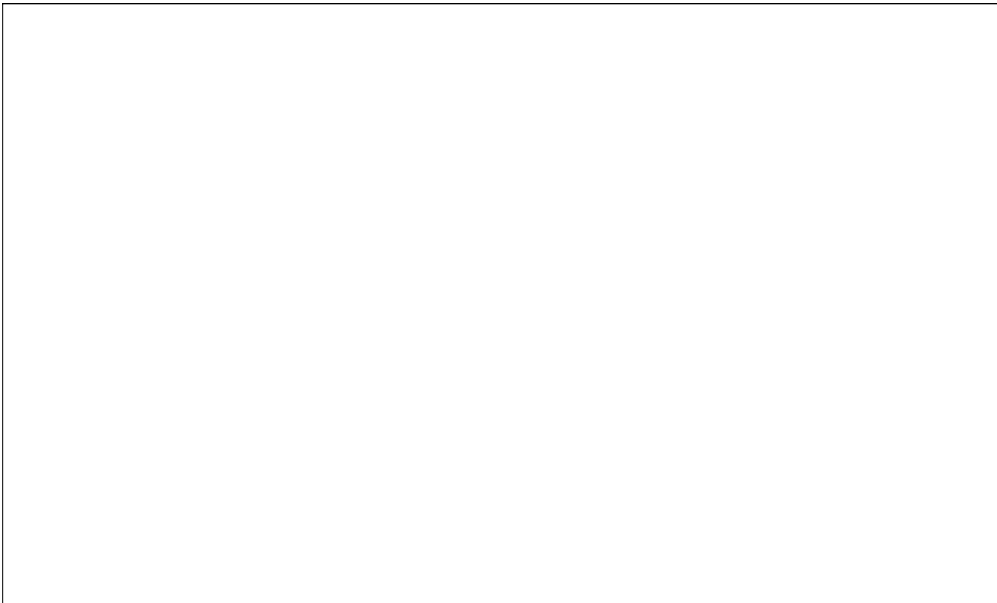
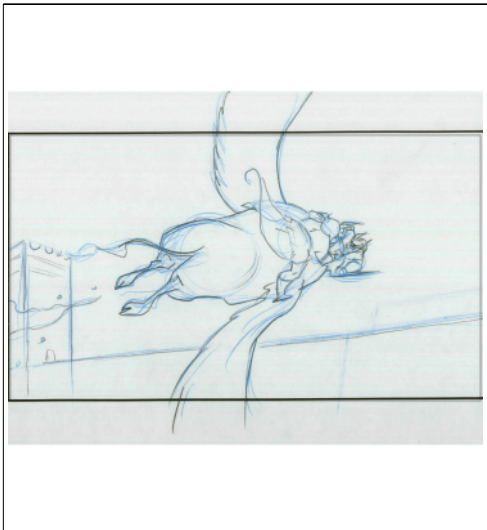

Seq	Scene	Panel
27	951	5

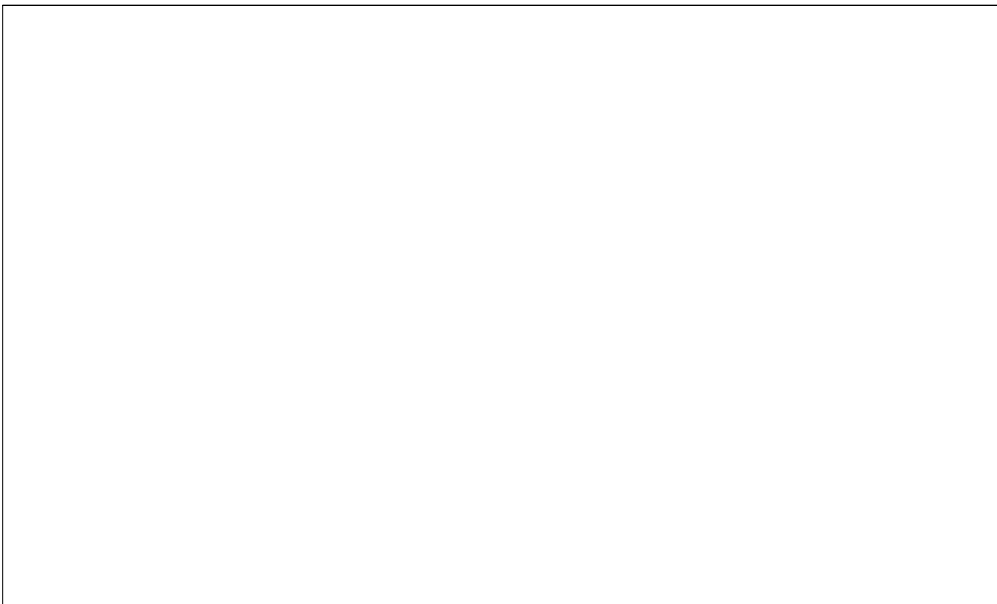
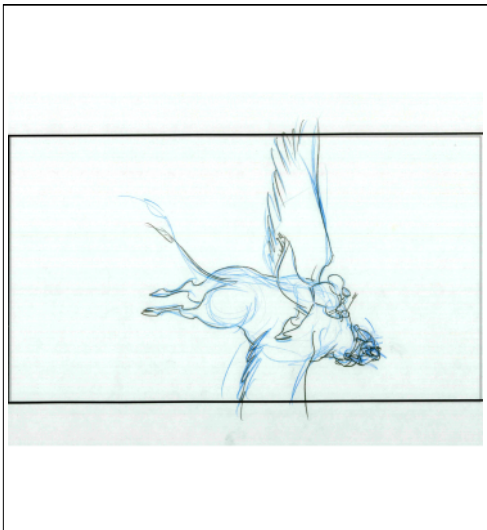

Seq	Scene	Panel
27	952	1

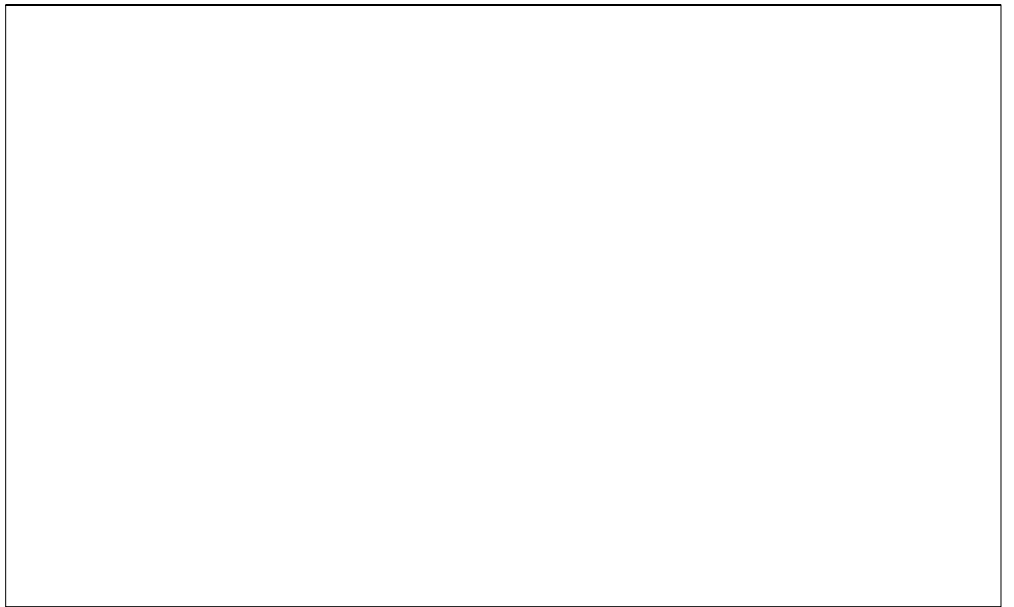
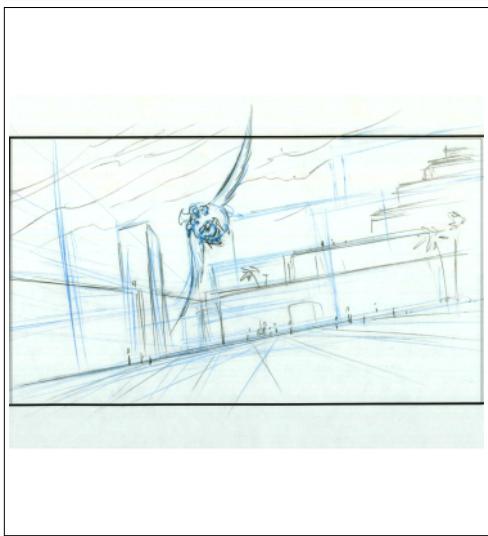

Seq	Scene	Panel
27	953	1

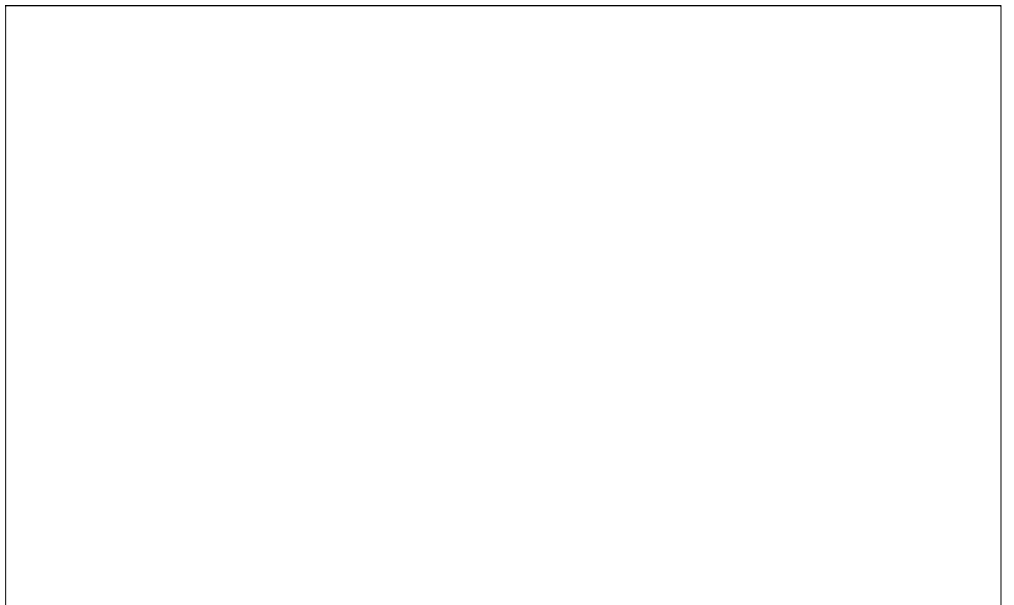
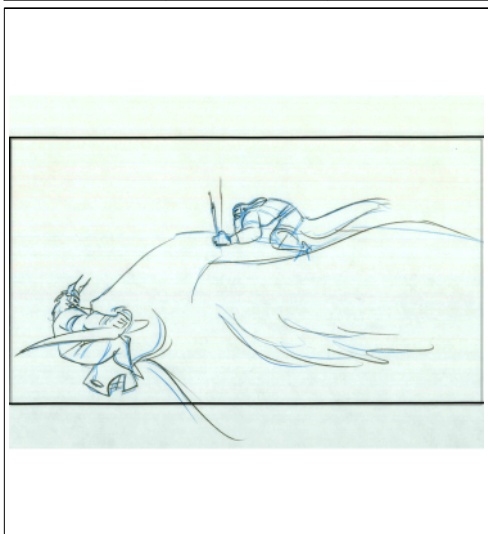

Seq	Scene	Panel
27	953	2

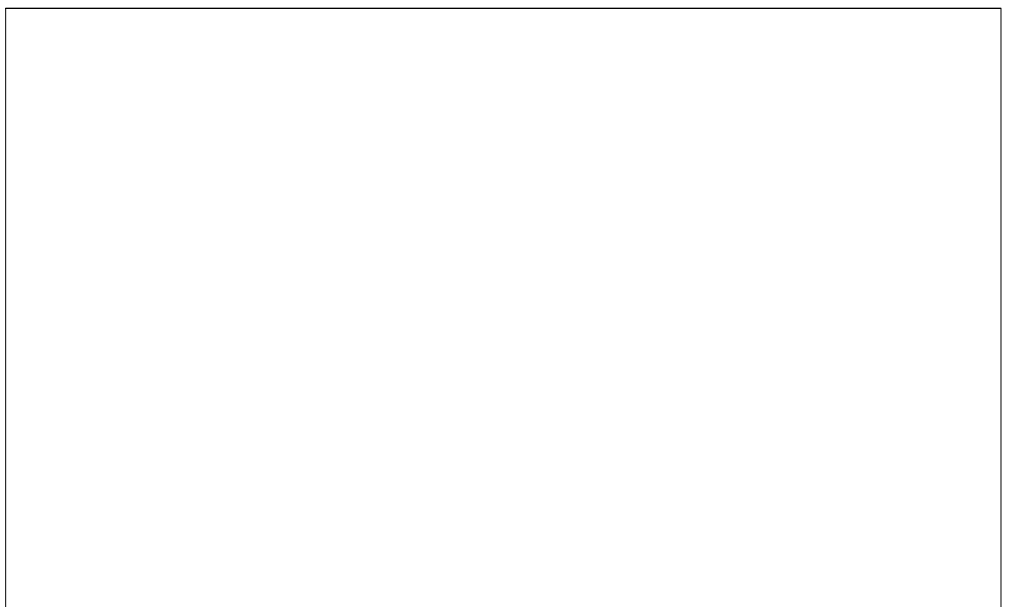
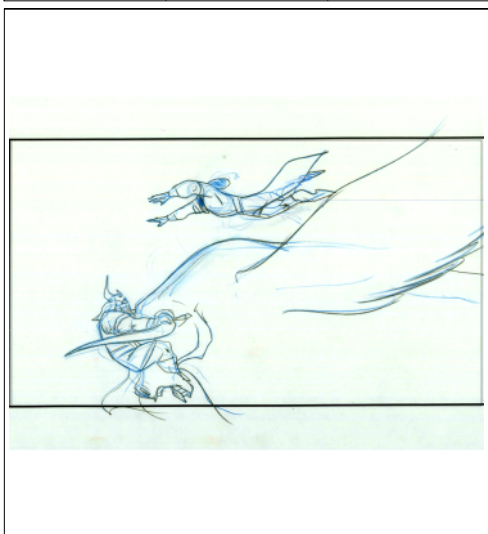

Seq	Scene	Panel
27	953	3

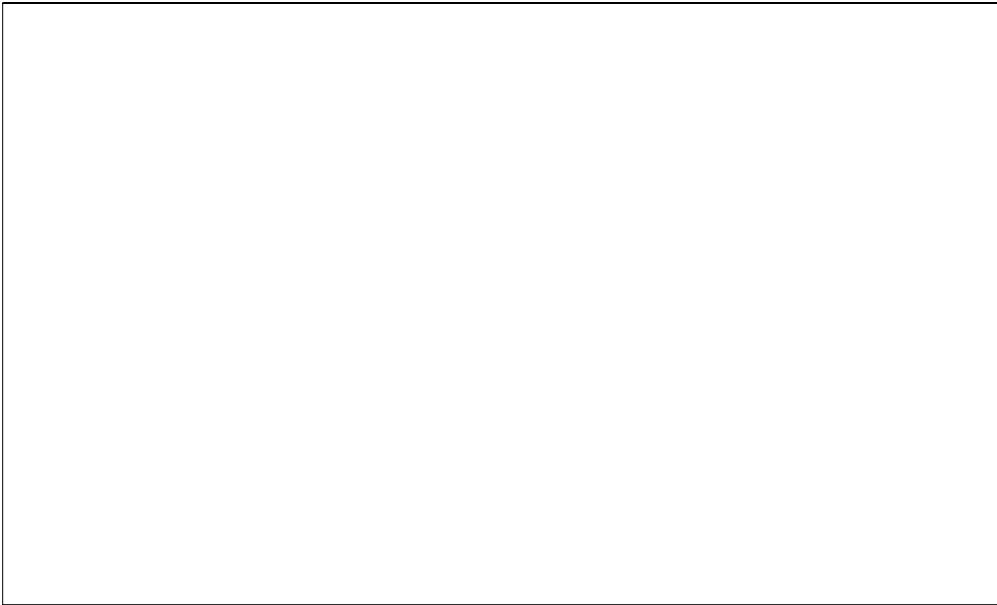
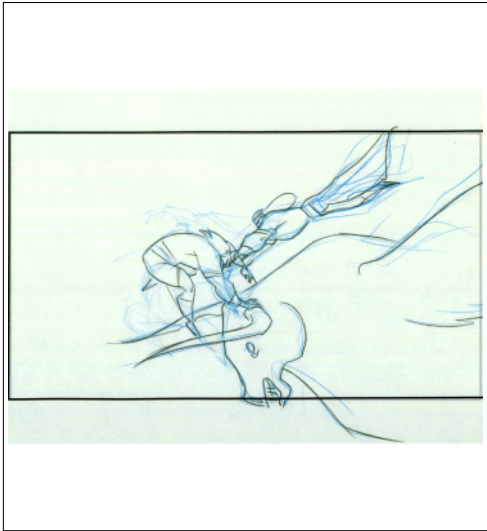

Seq	Scene	Panel
27	953	4

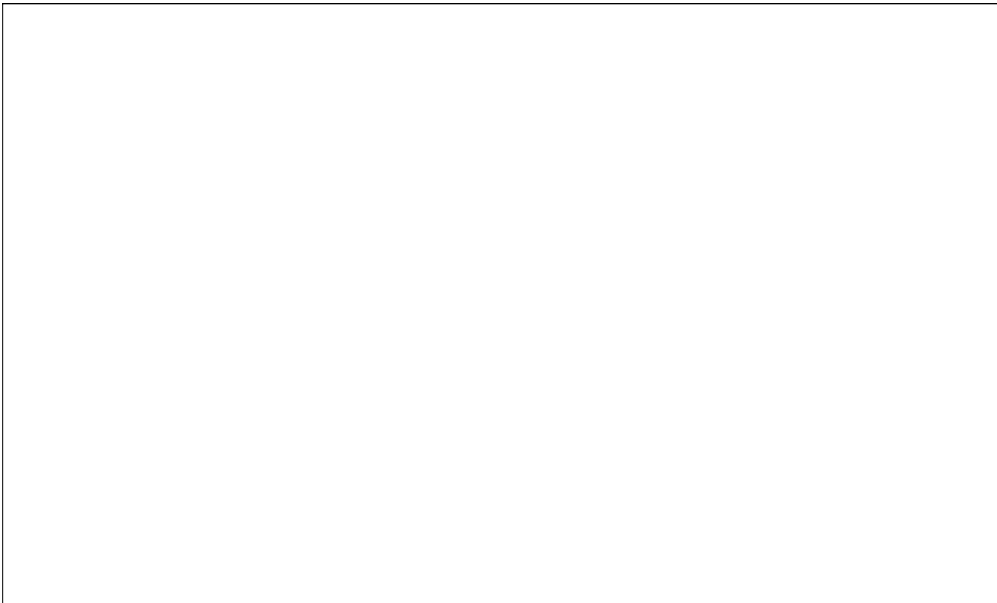
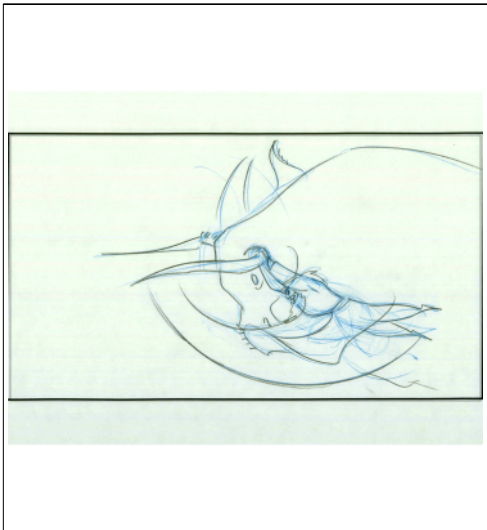

Seq	Scene	Panel
27	954	1

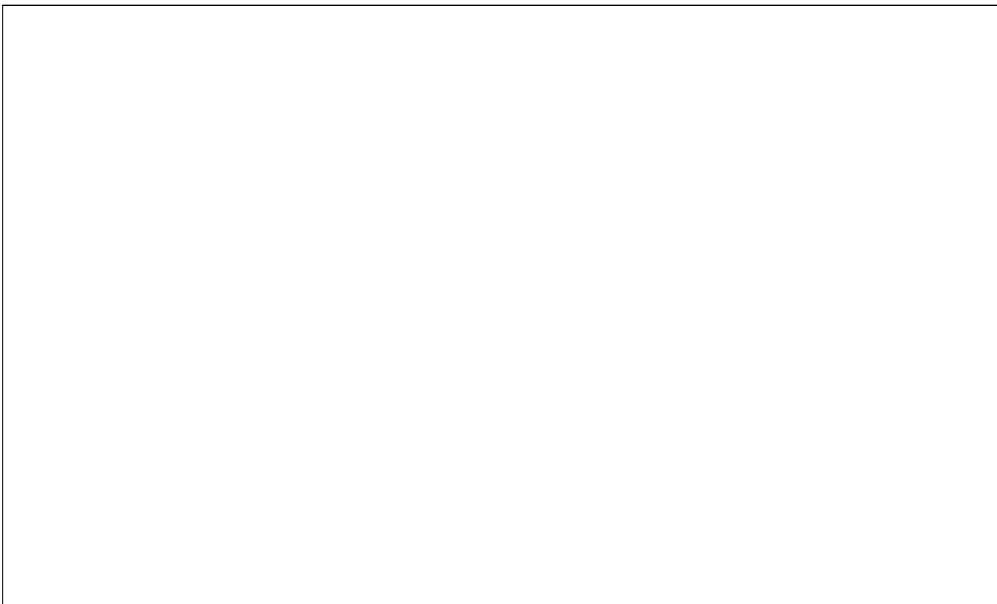

Seq	Scene	Panel
27	954	2

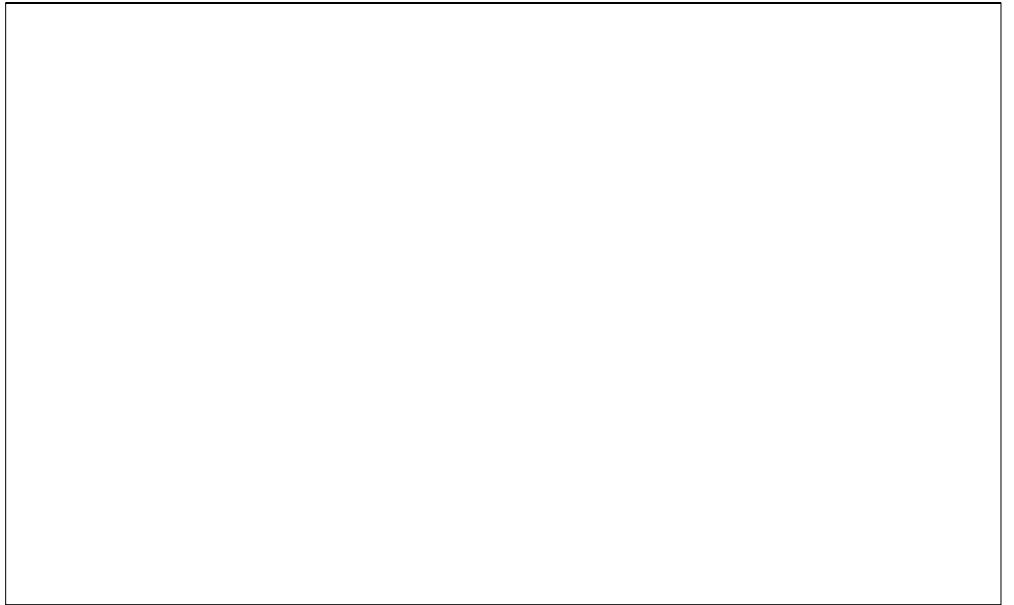
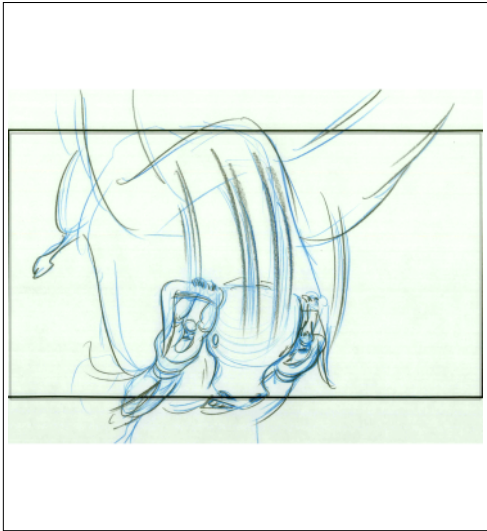

Seq	Scene	Panel
27	954	3

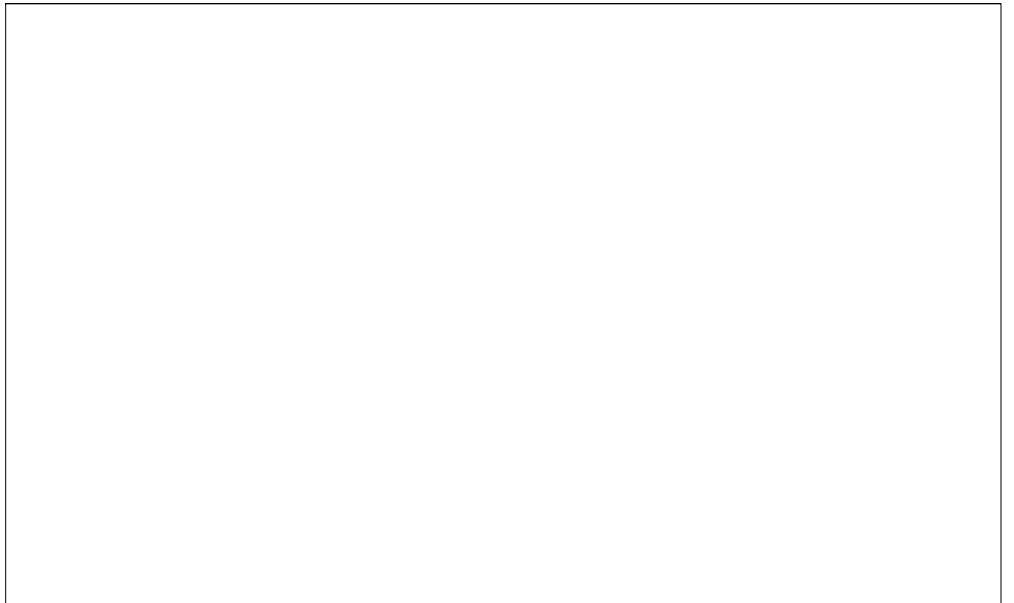
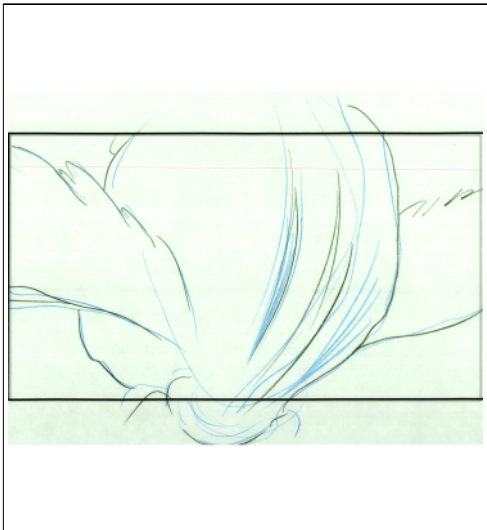

Seq	Scene	Panel
27	955	1

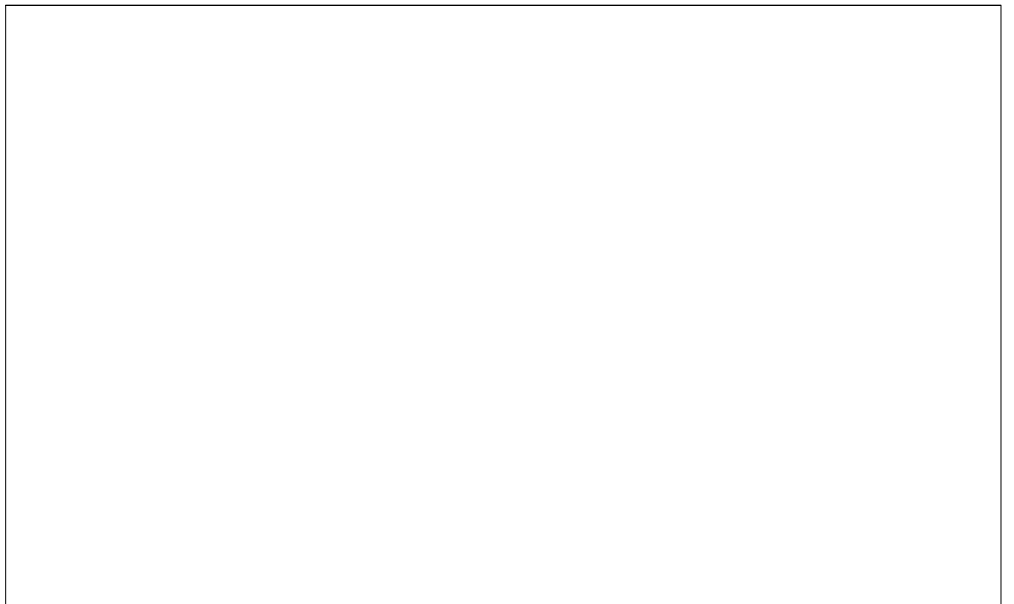
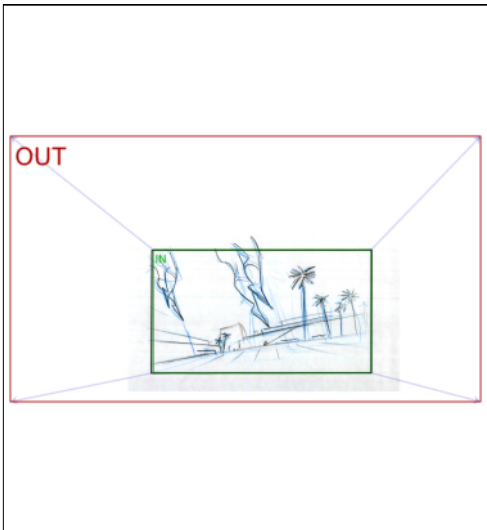

Seq	Scene	Panel
27	955	2

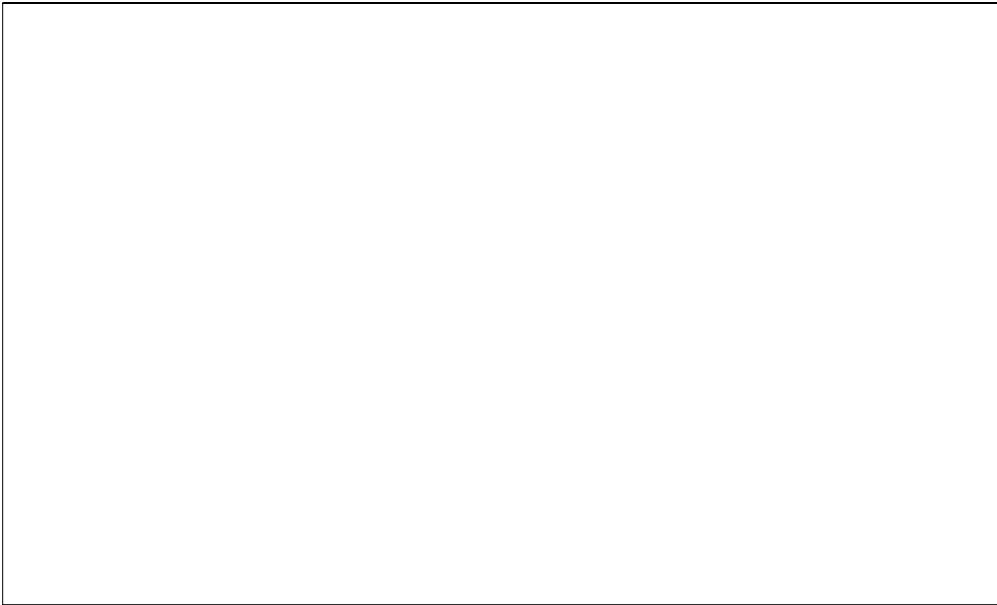
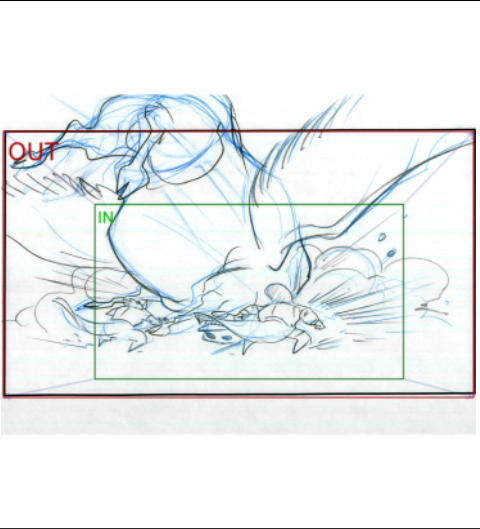

Seq	Scene	Panel
27	955	3

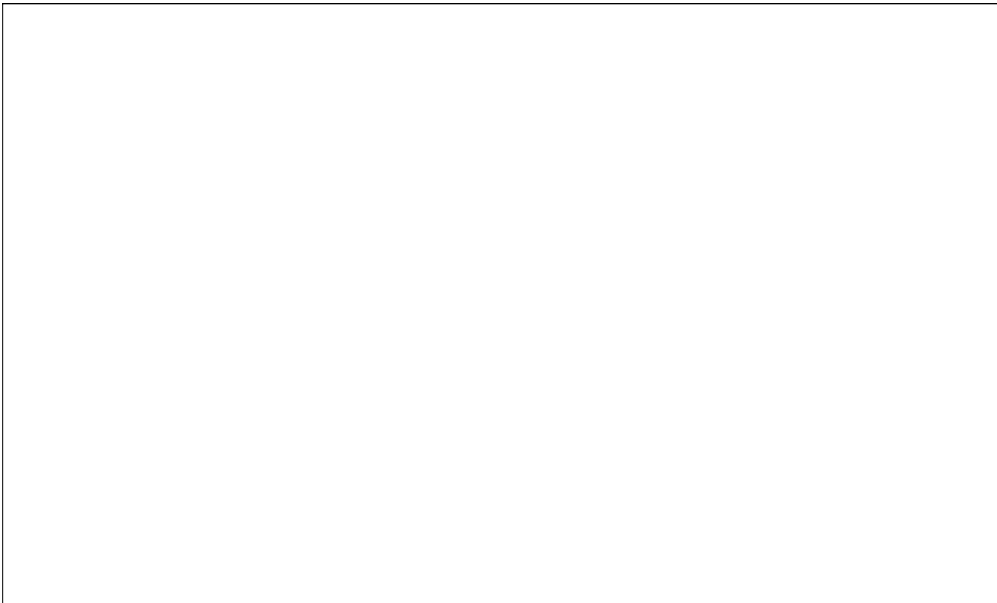
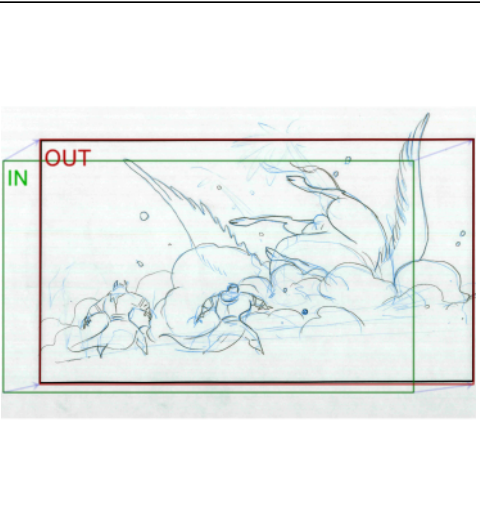

Seq	Scene	Panel
27	955	4

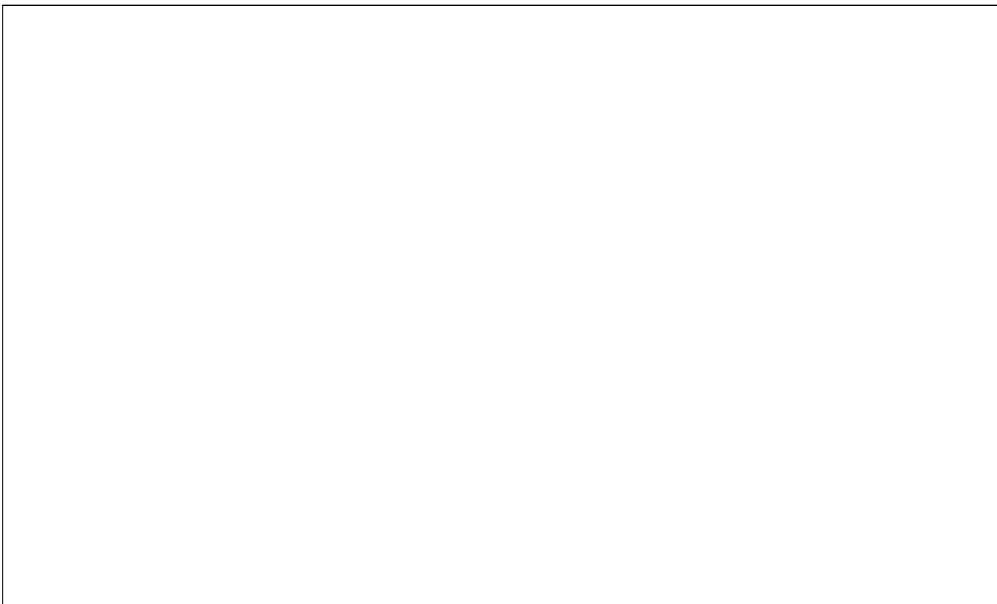
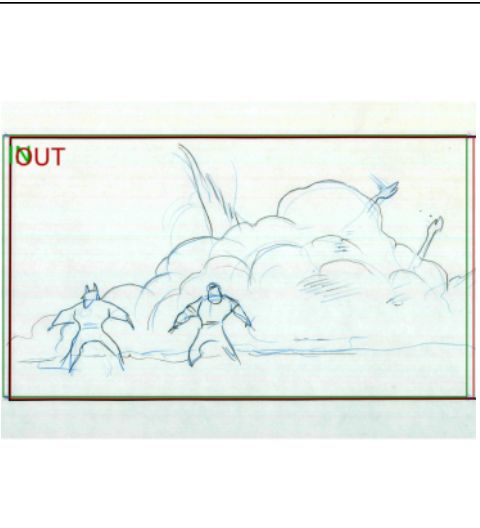

Seq	Scene	Panel
27	955	5

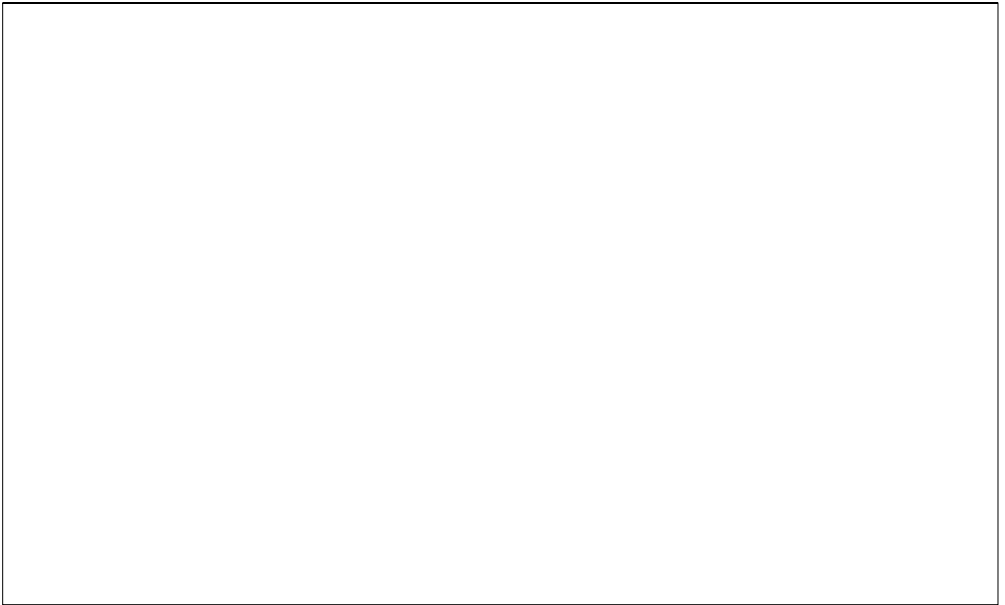
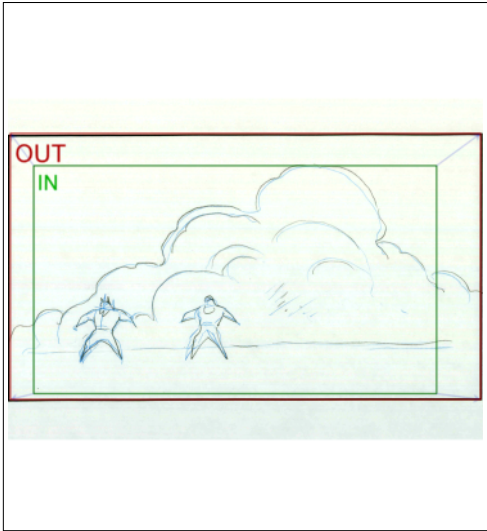

Seq	Scene	Panel
27	956	1

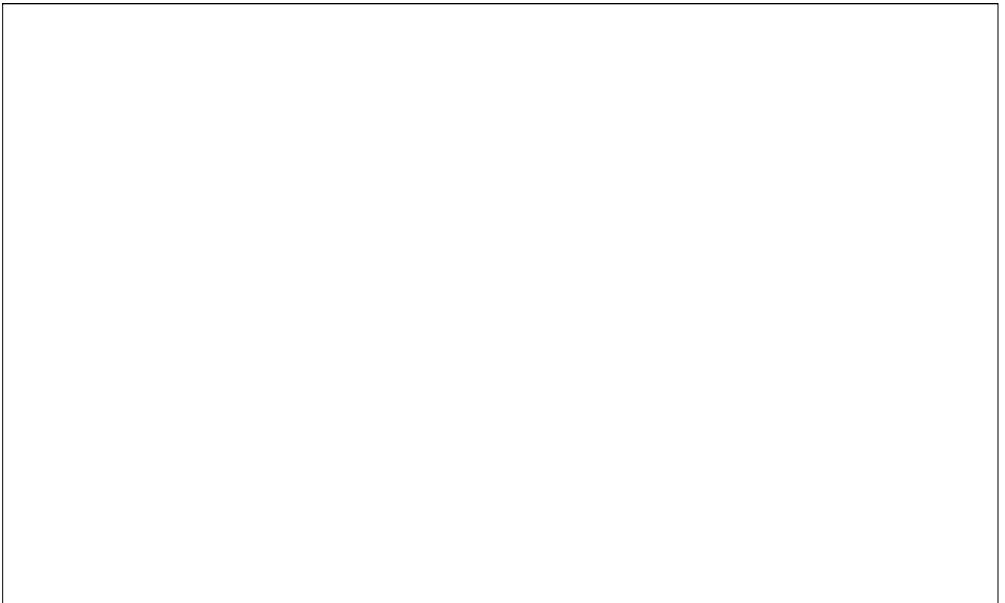

Seq	Scene	Panel
27	957	1

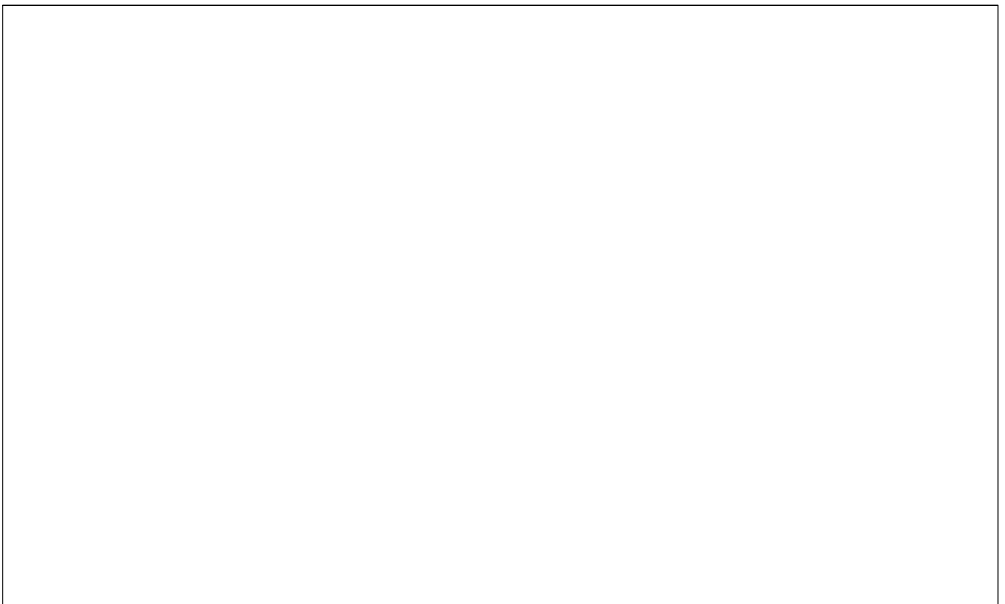
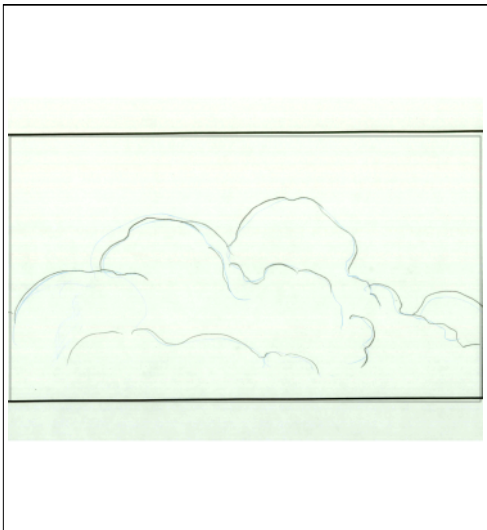

Seq	Scene	Panel
27	957	2

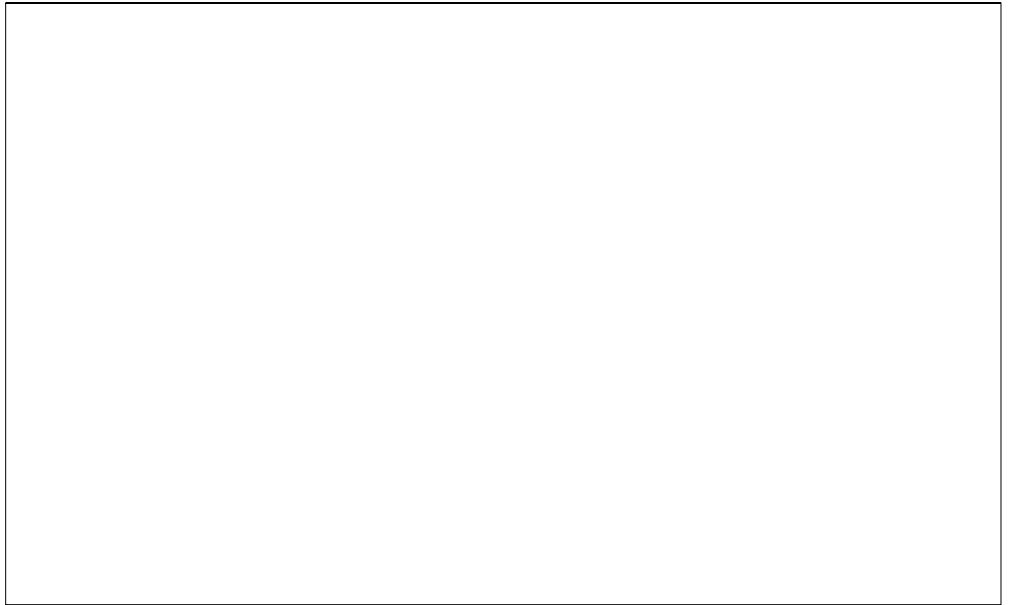

Seq	Scene	Panel
27	958	1



Dialog
ARMERO EN OFF :
"GILGAMESH! ENKIDU!"

Seq	Scene	Panel
27	958	2

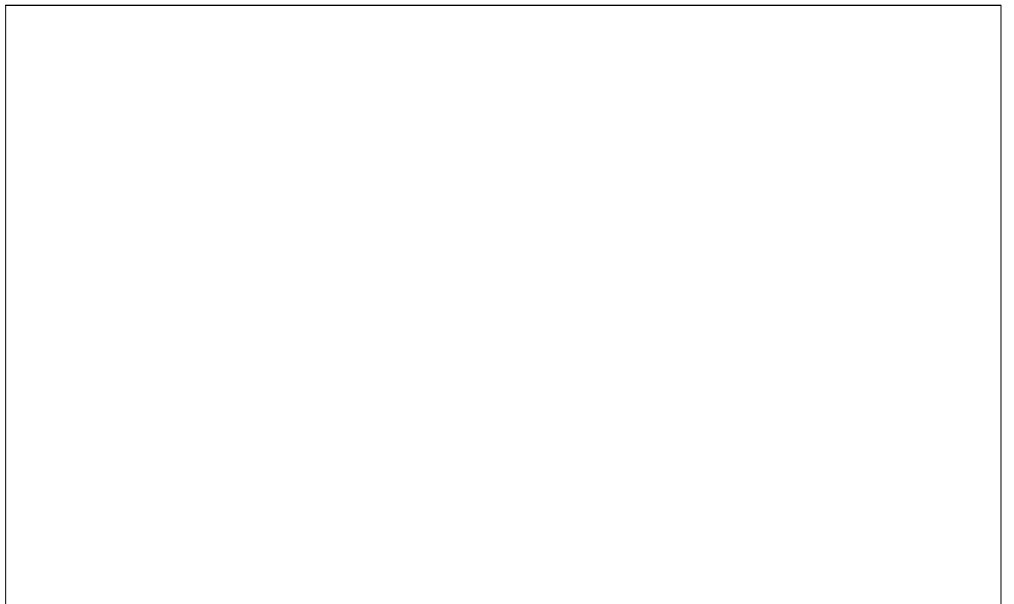
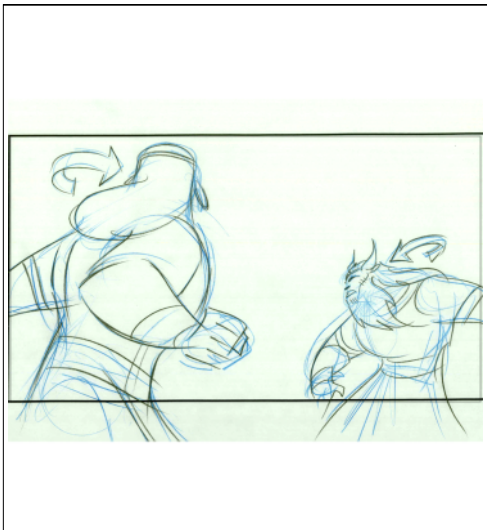

Seq	Scene	Panel
27	959	1

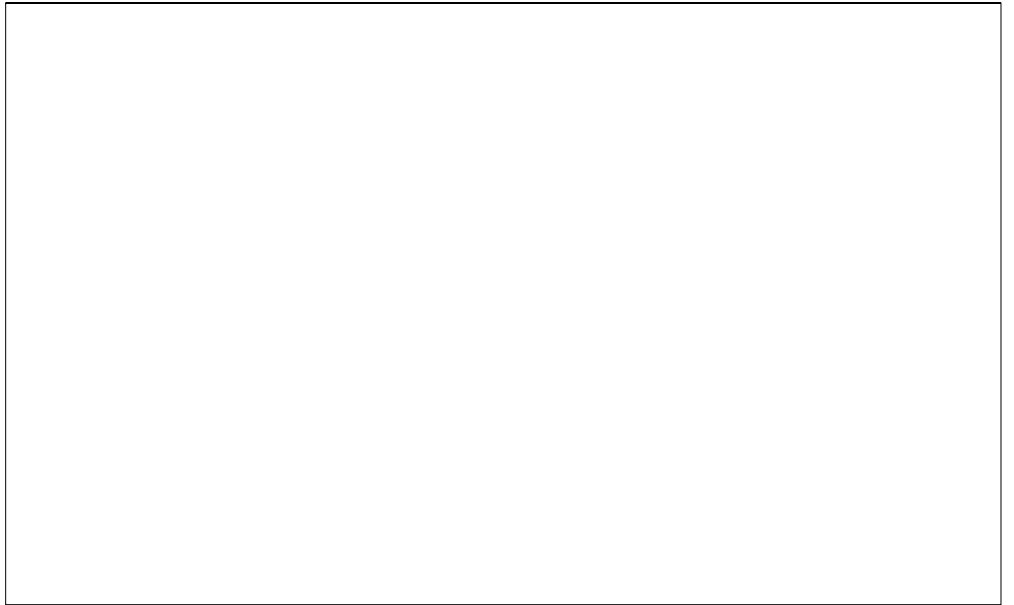
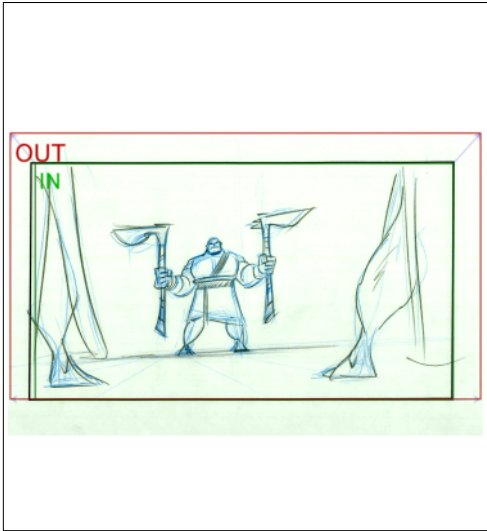

Seq	Scene	Panel
27	959	2

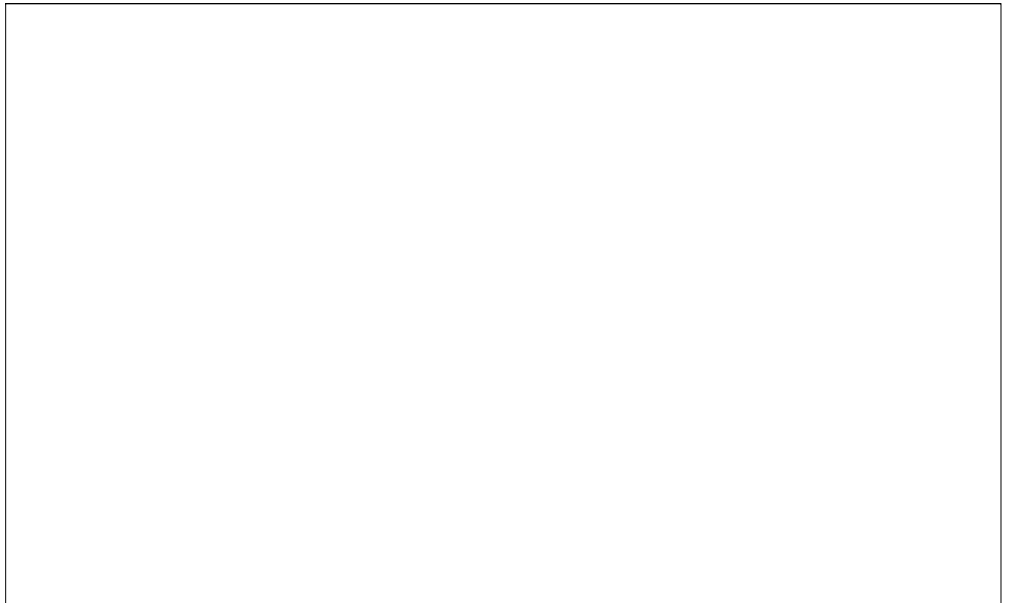
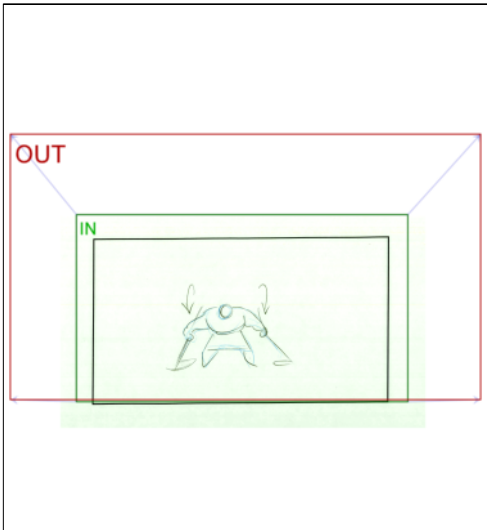

Seq	Scene	Panel
27	959	3

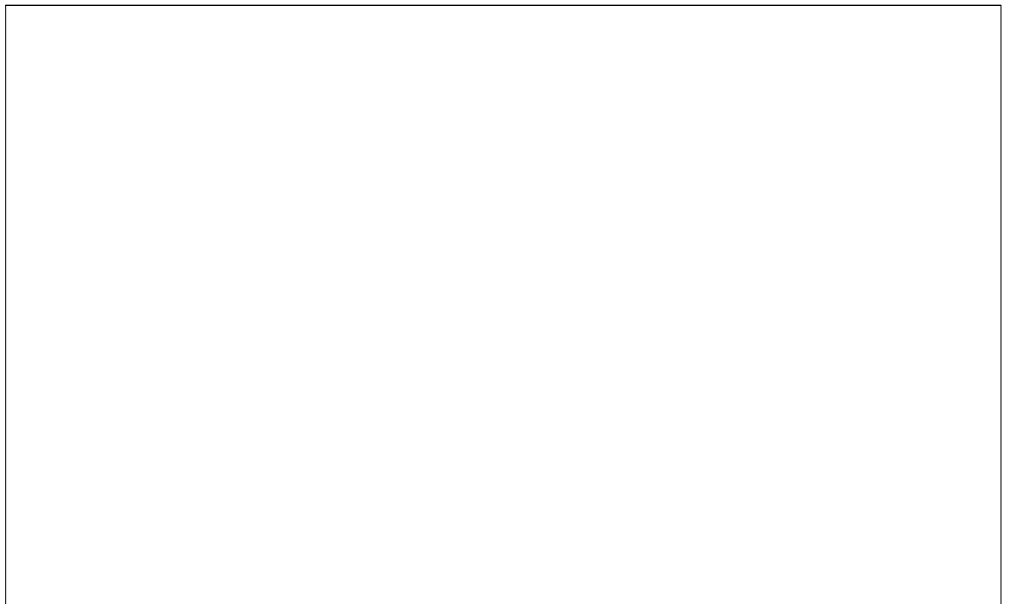
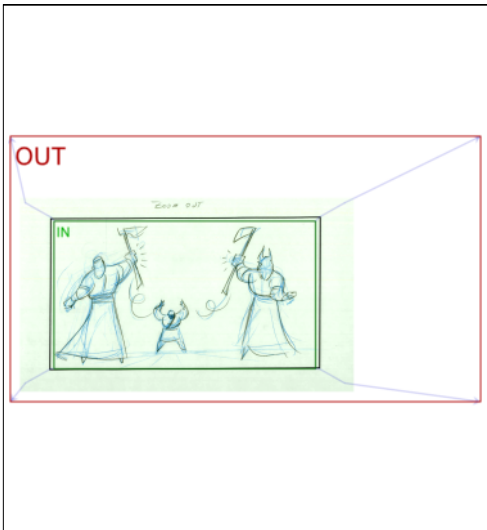

Seq	Scene	Panel
27	959	4

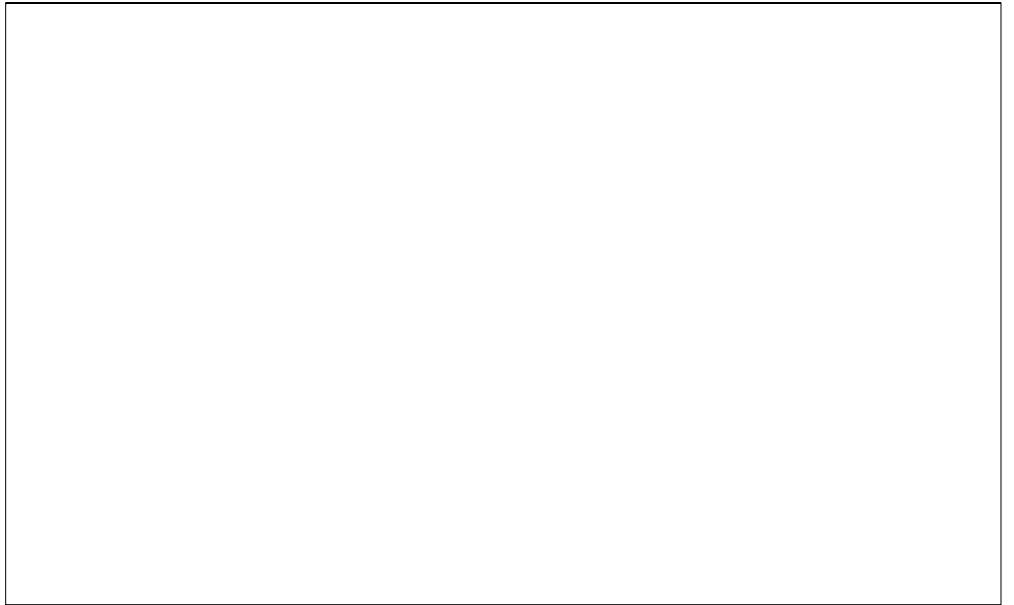
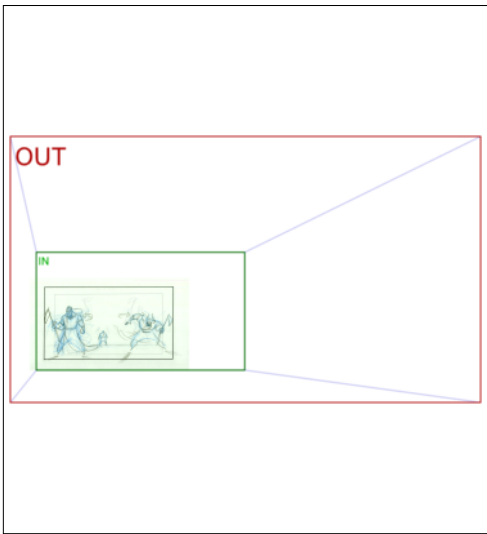

Seq	Scene	Panel
27	959	5

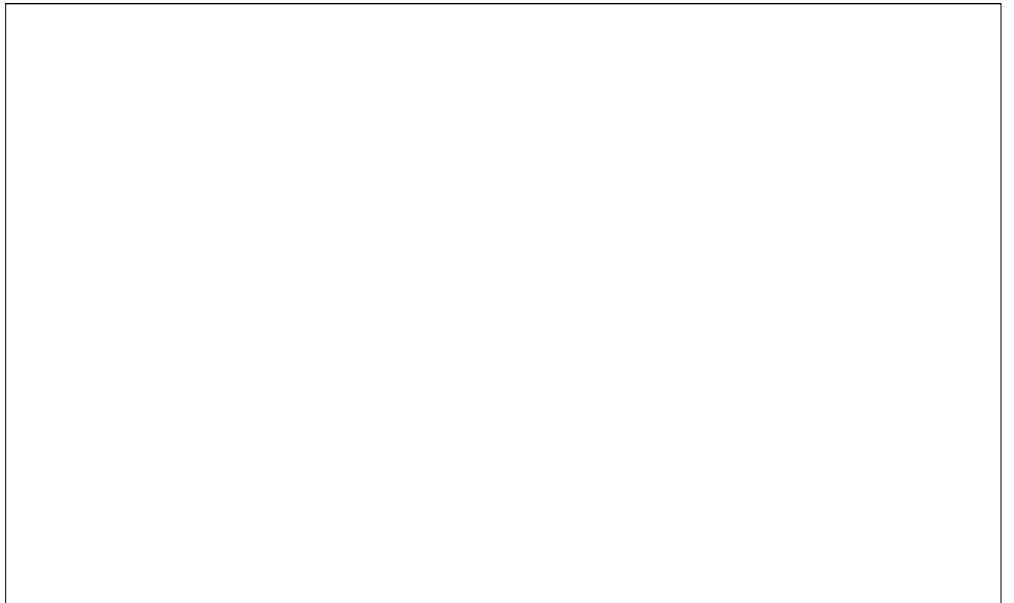

Seq	Scene	Panel
27	960	1

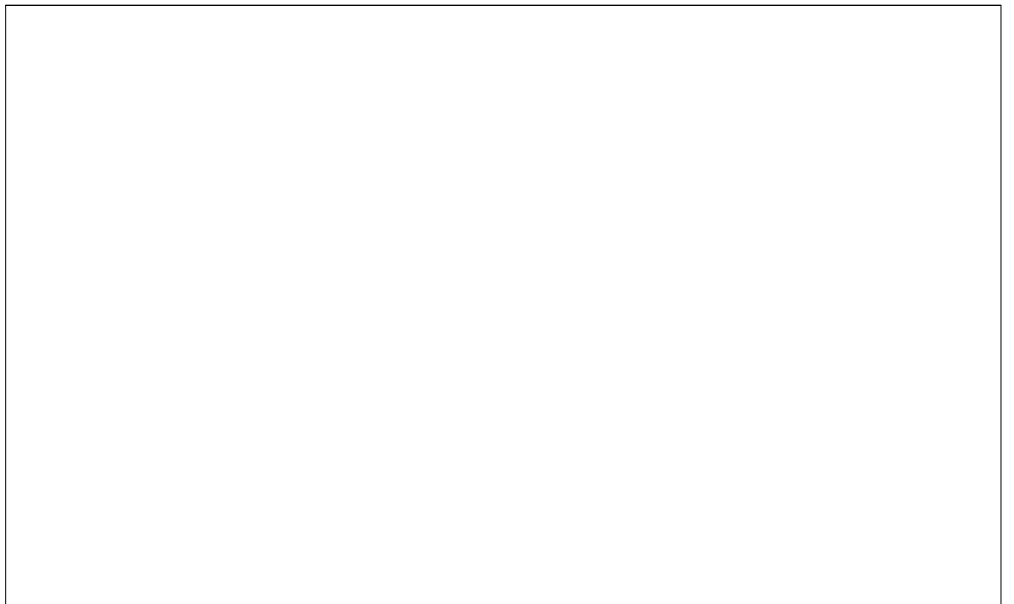
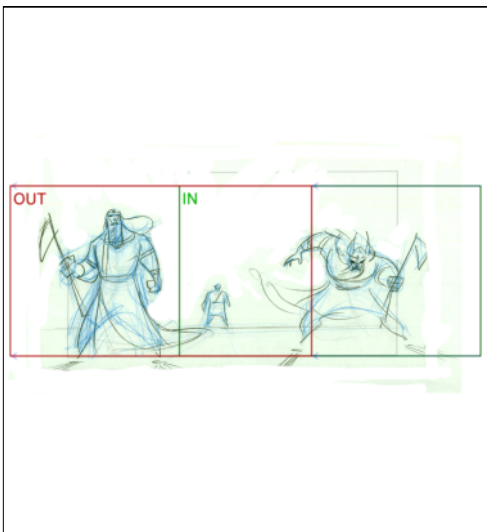

Seq	Scene	Panel
27	961	1

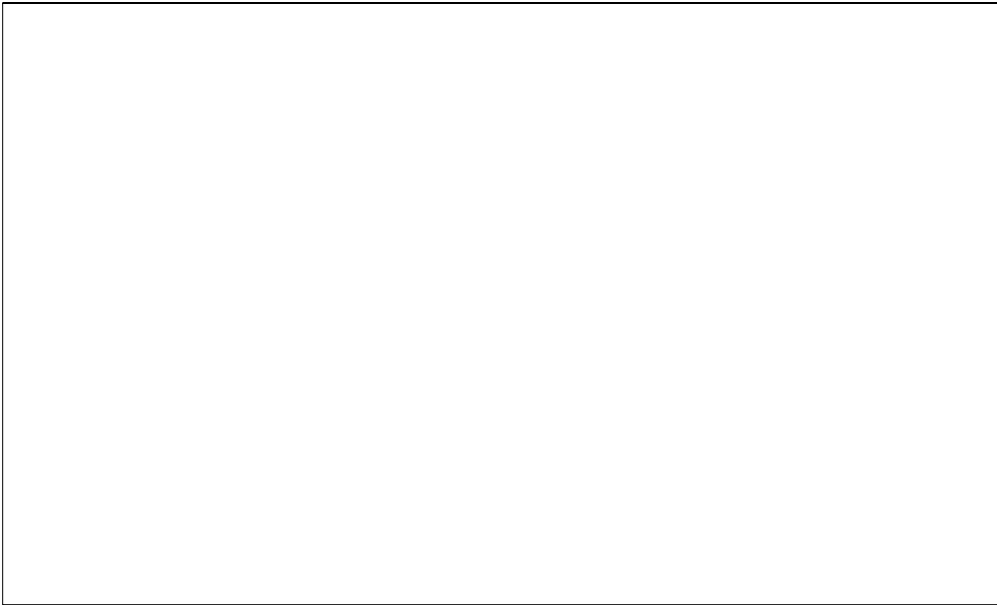
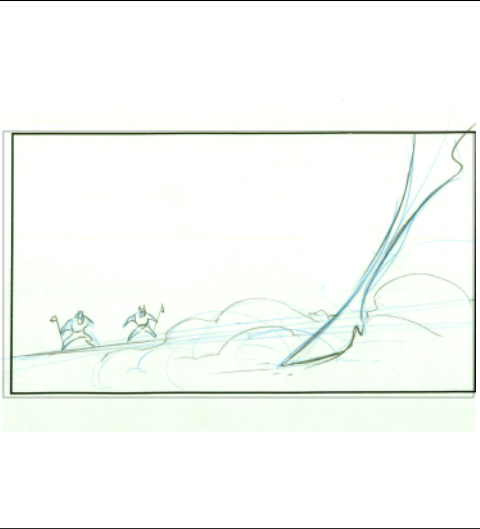

Seq	Scene	Panel
27	961	2

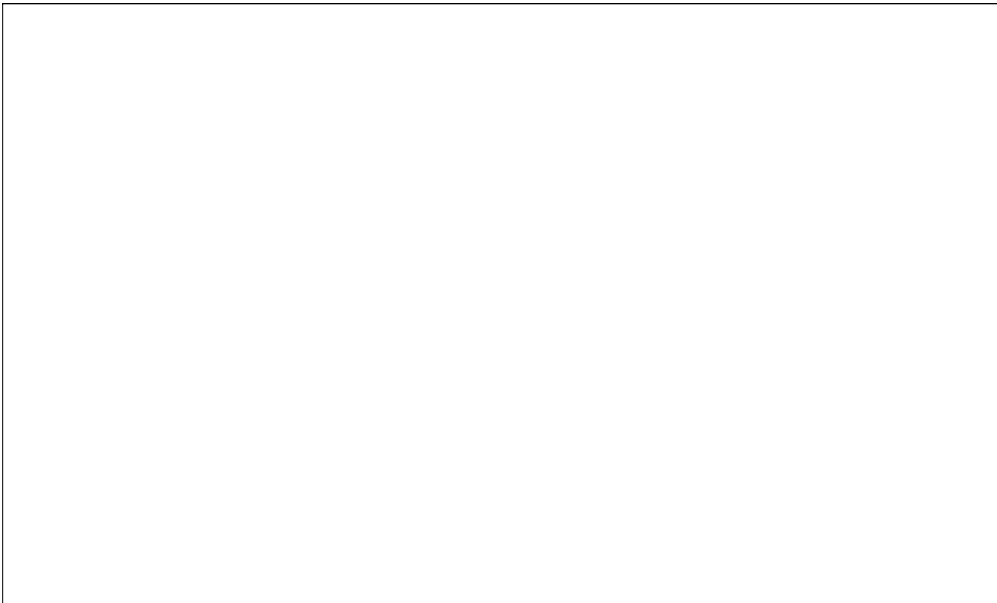

Seq	Scene	Panel
27	962	1

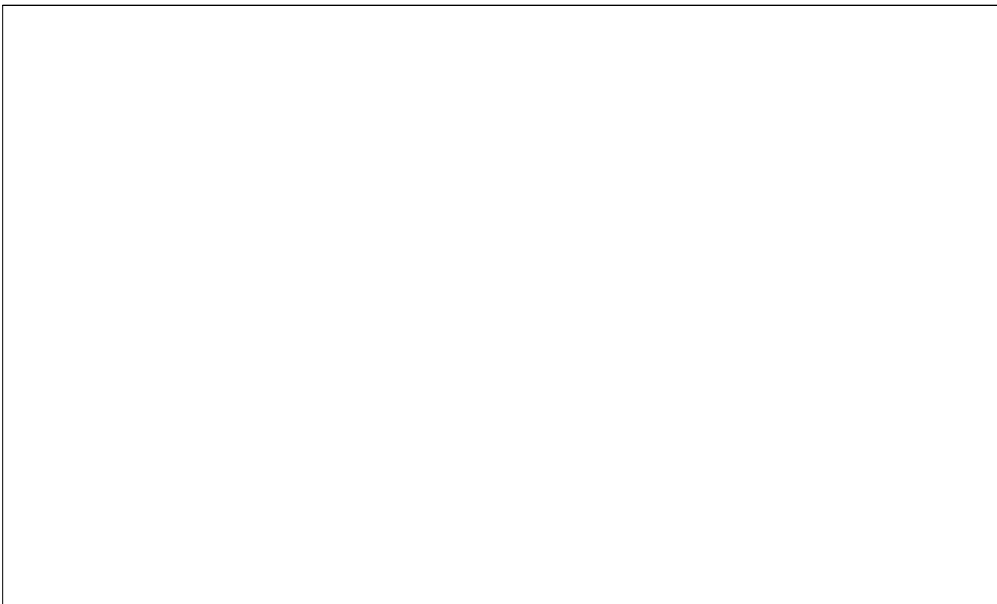
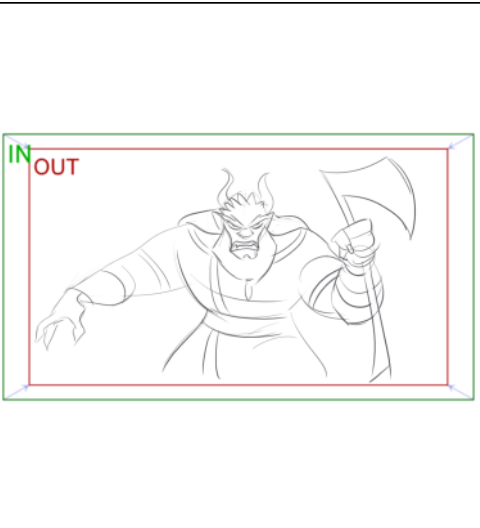

Seq	Scene	Panel
27	963	1

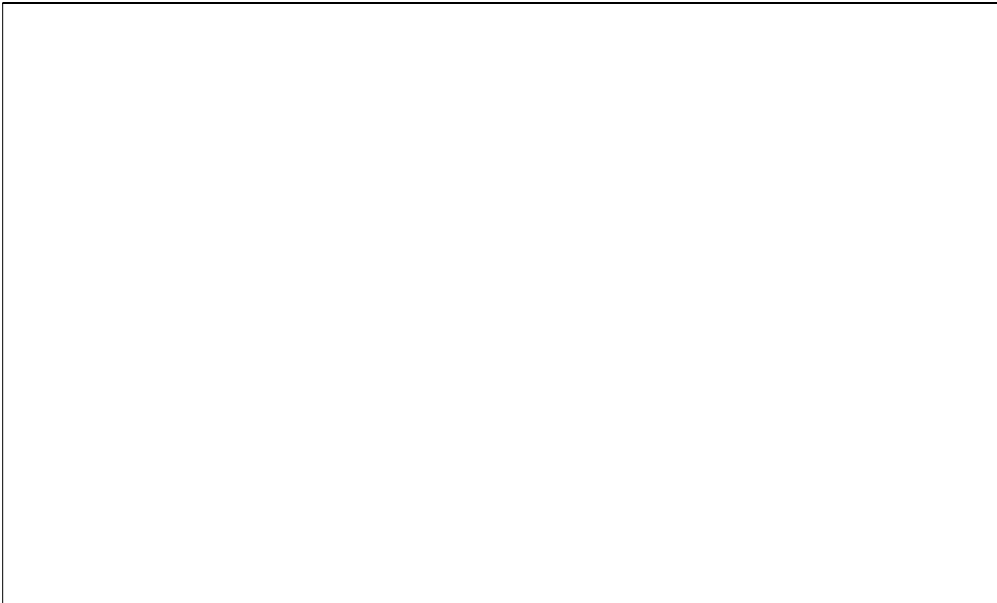

Seq	Scene	Panel
27	964	1

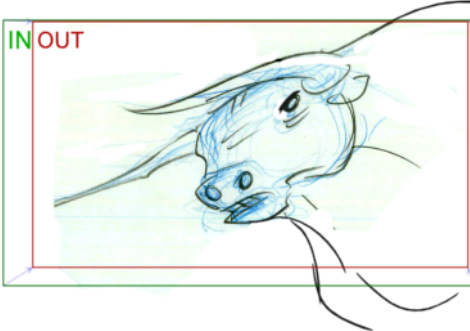

Seq	Scene	Panel
27	965	1

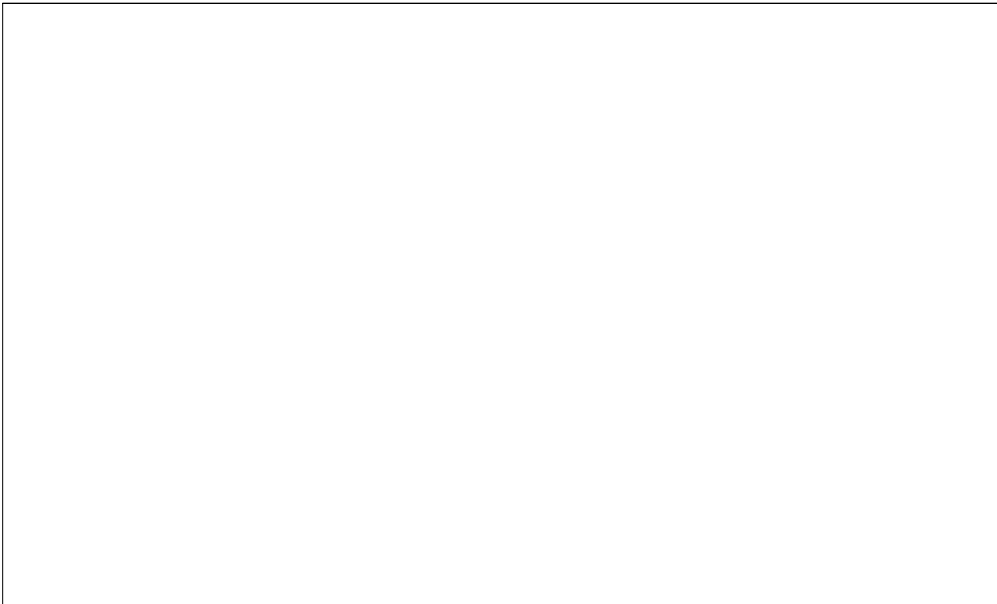
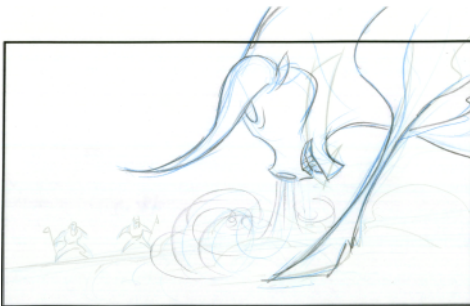

Seq	Scene	Panel
27	965	2

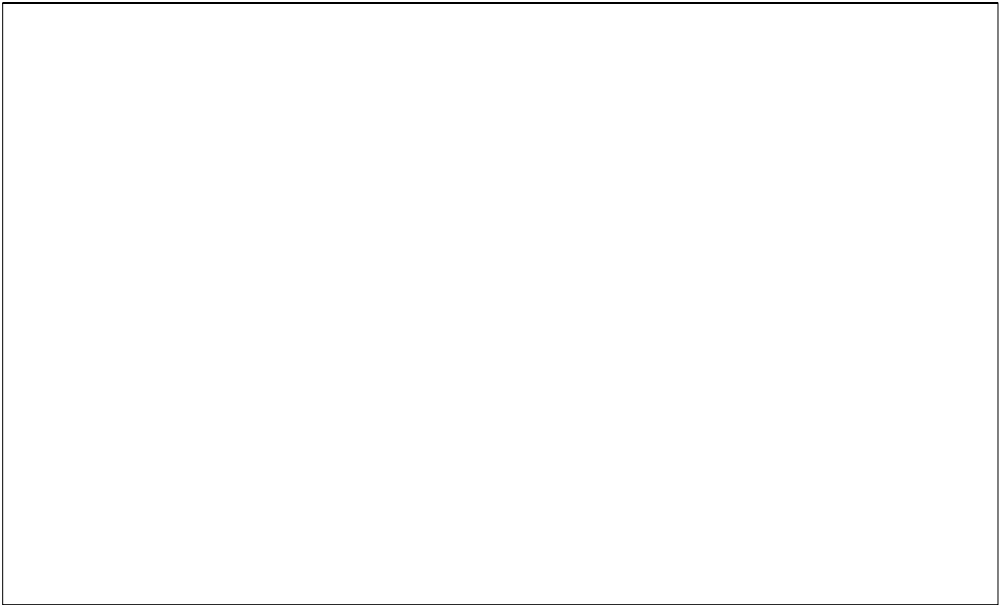
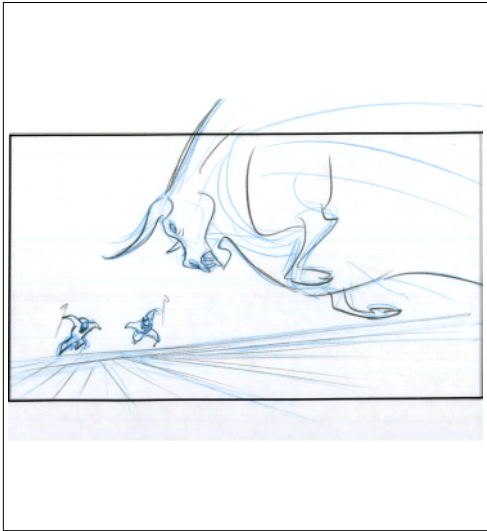

Seq	Scene	Panel
27	966	1

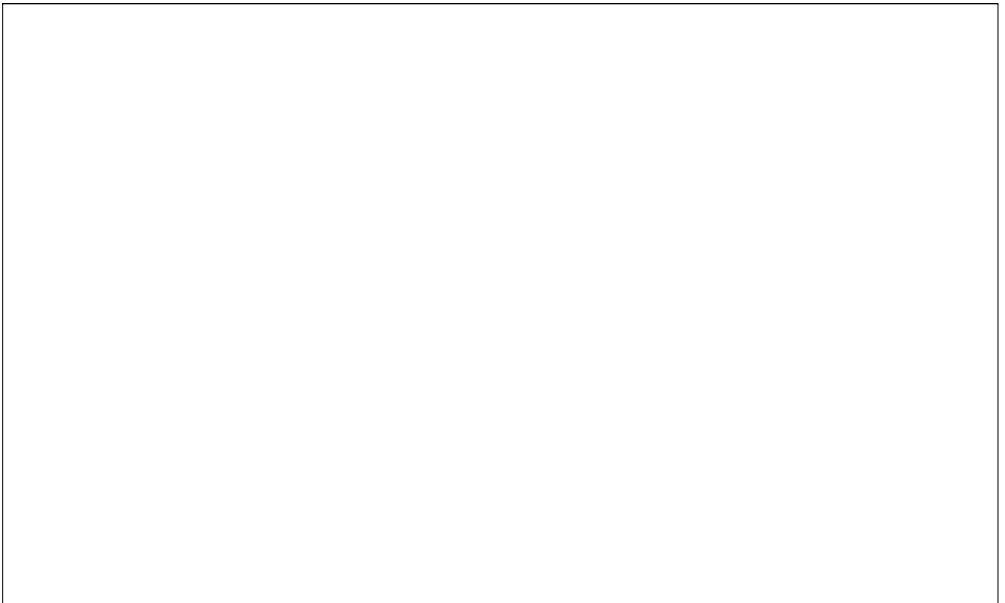
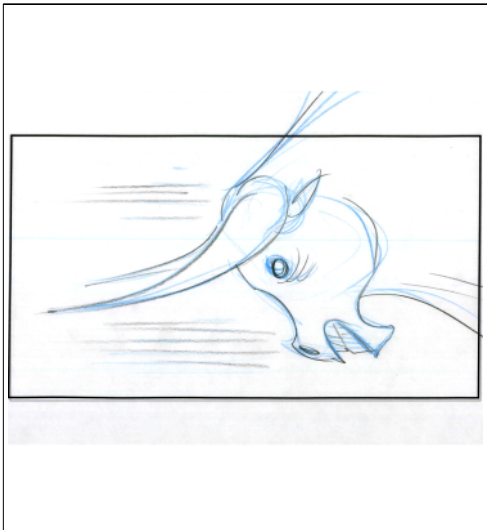

Seq	Scene	Panel
27	967	1

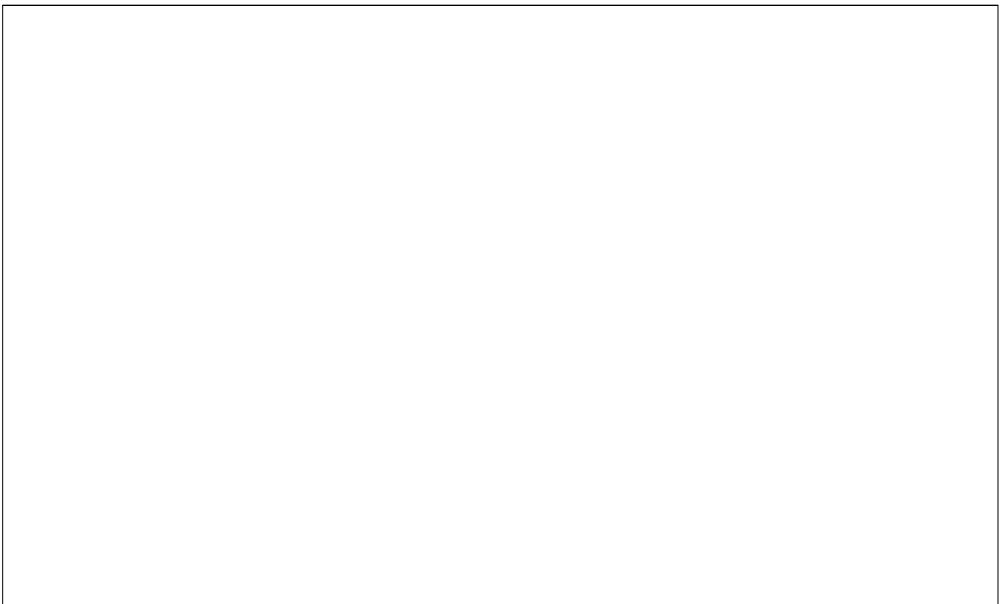
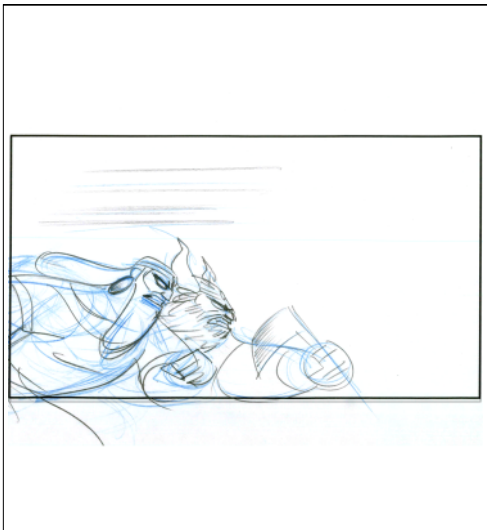

Seq	Scene	Panel
27	968	1

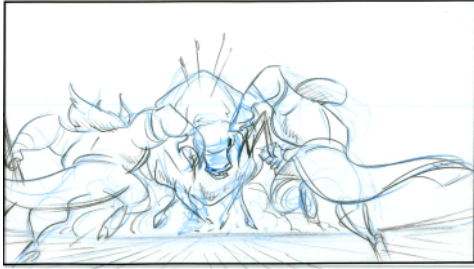

Seq	Scene	Panel
27	969	1

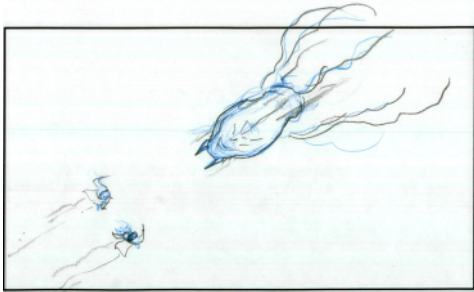

Seq	Scene	Panel
27	970	1

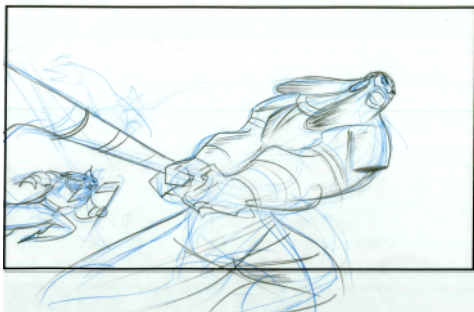

Seq	Scene	Panel
27	970	2

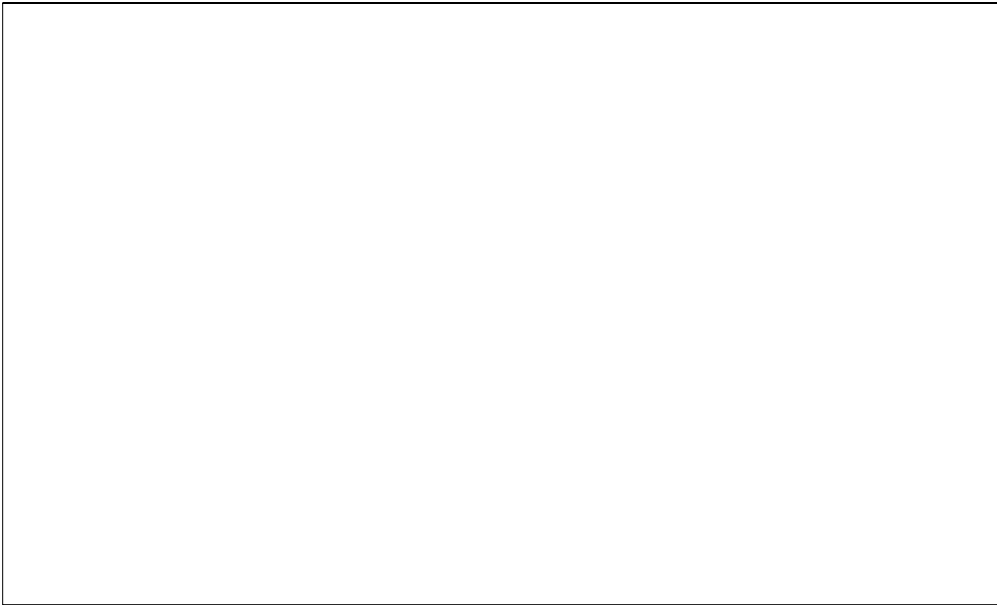
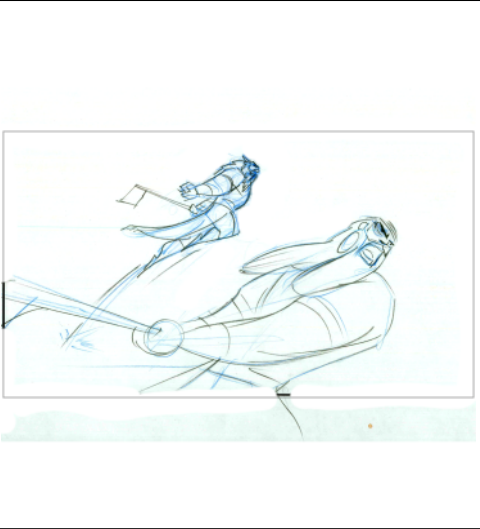

Seq	Scene	Panel
27	971	1

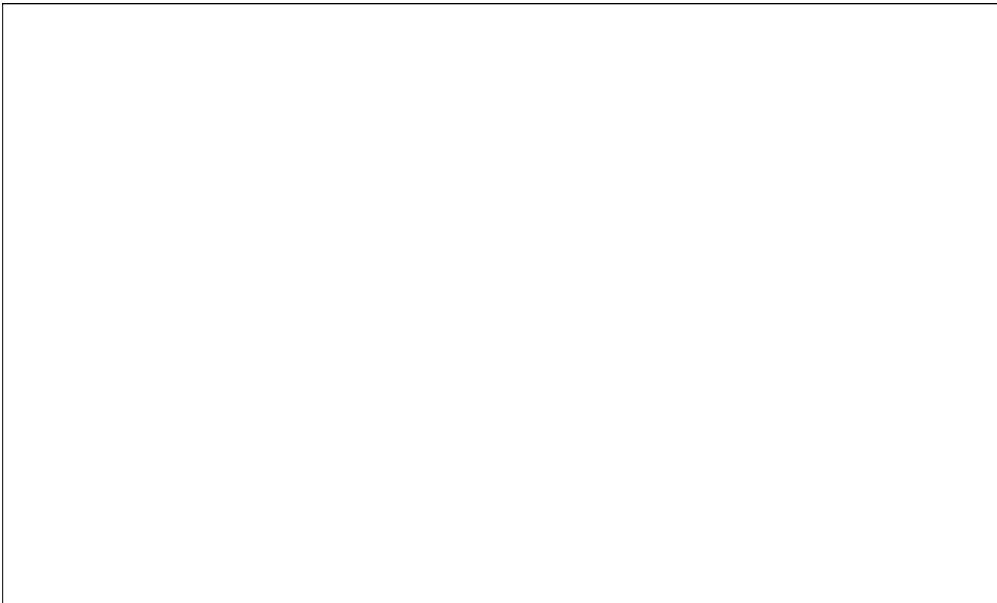
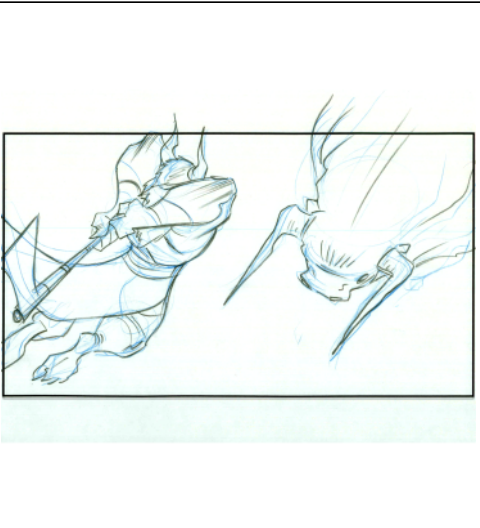

Seq	Scene	Panel
27	972	1

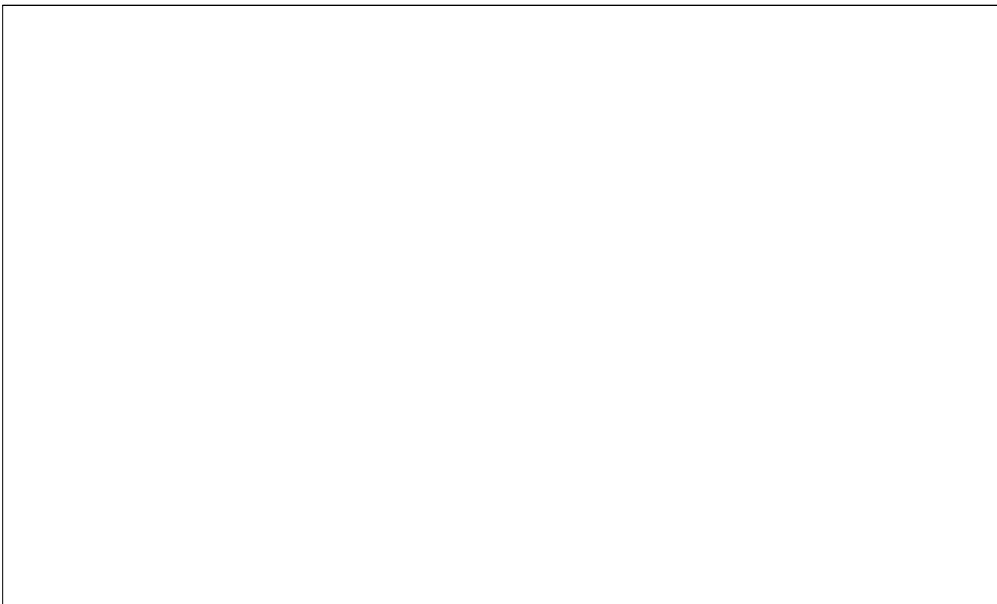
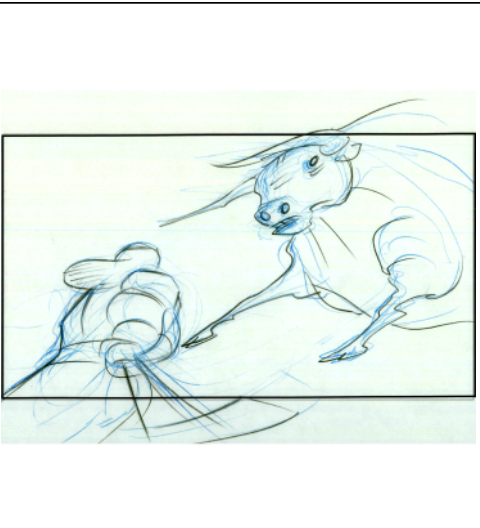

Seq	Scene	Panel
27	973	1

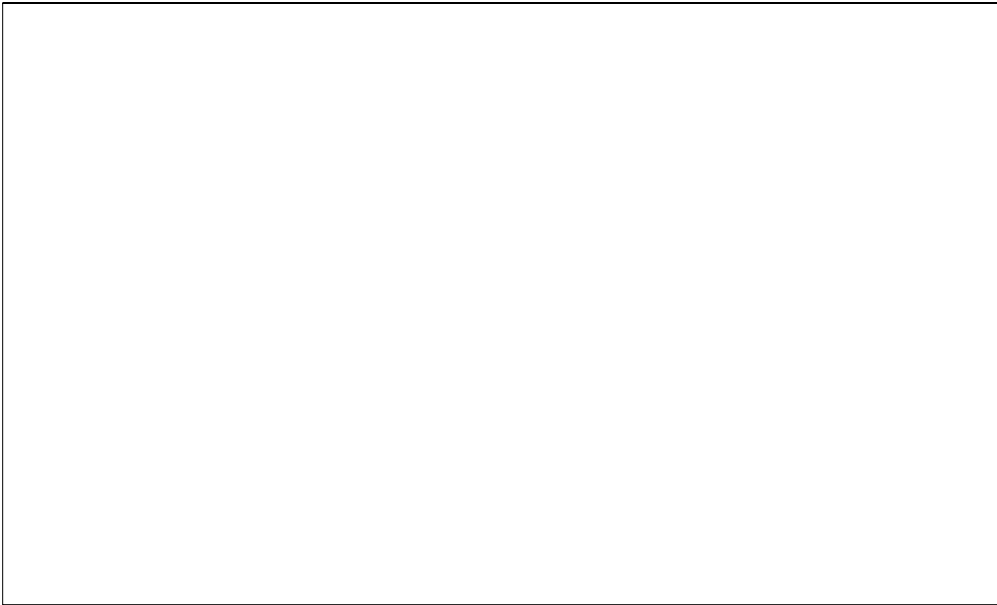
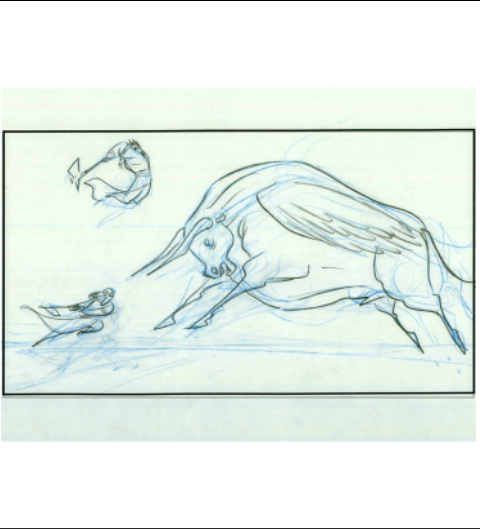

Seq	Scene	Panel
27	974	1

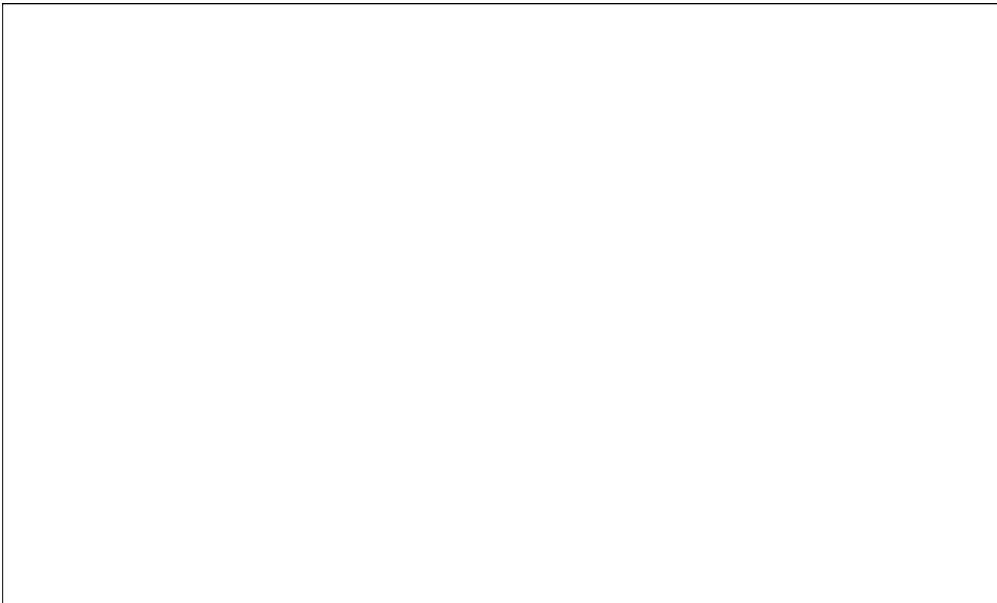
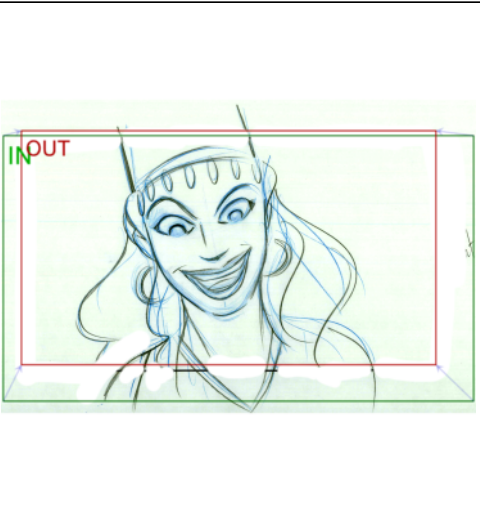

Seq	Scene	Panel
27	975	1

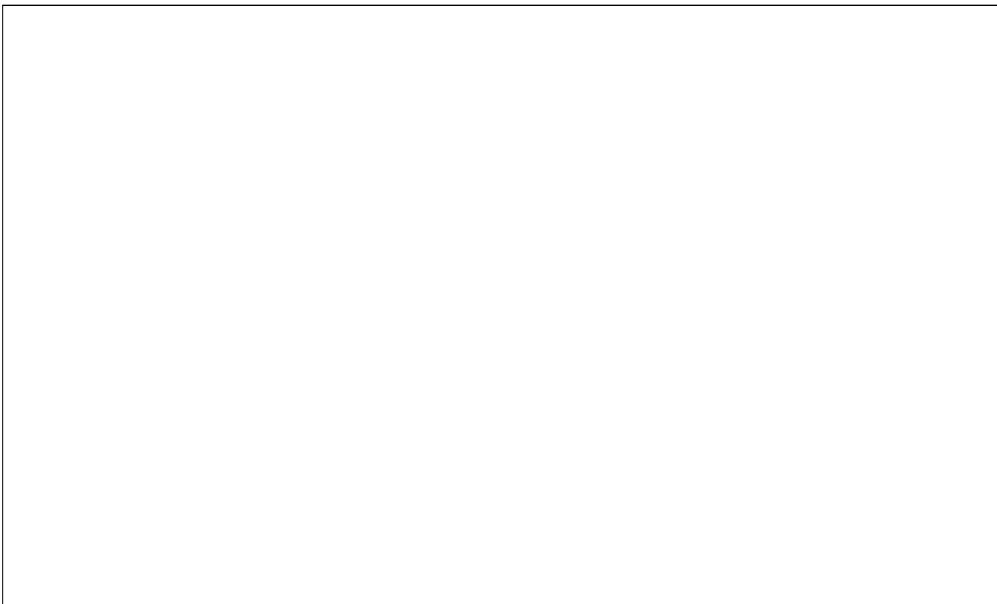
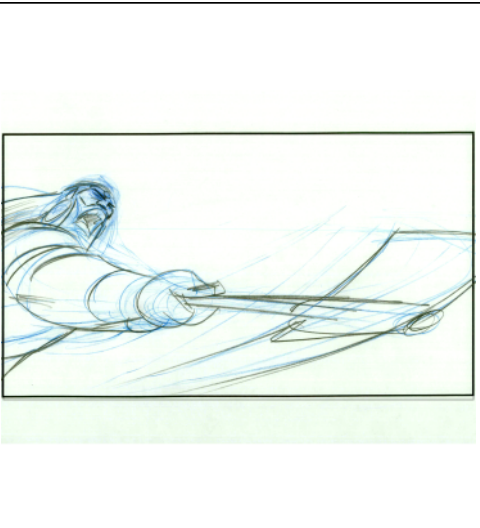

Seq	Scene	Panel
27	976	1

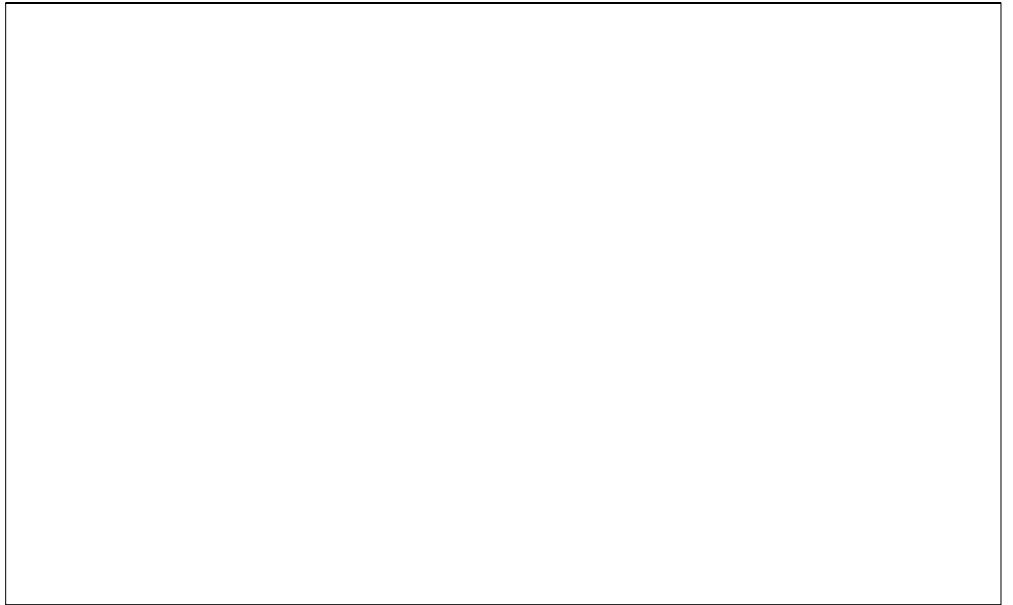
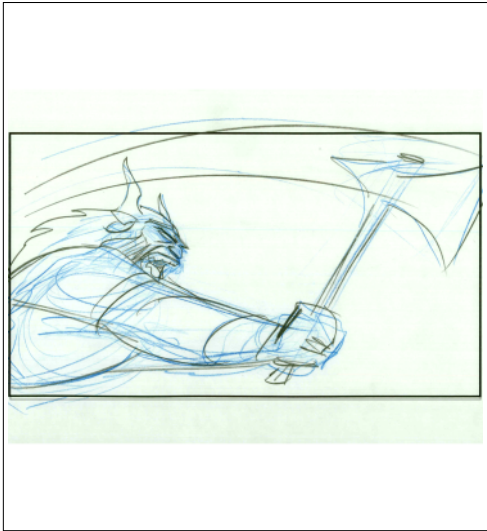

Seq	Scene	Panel
27	977	1

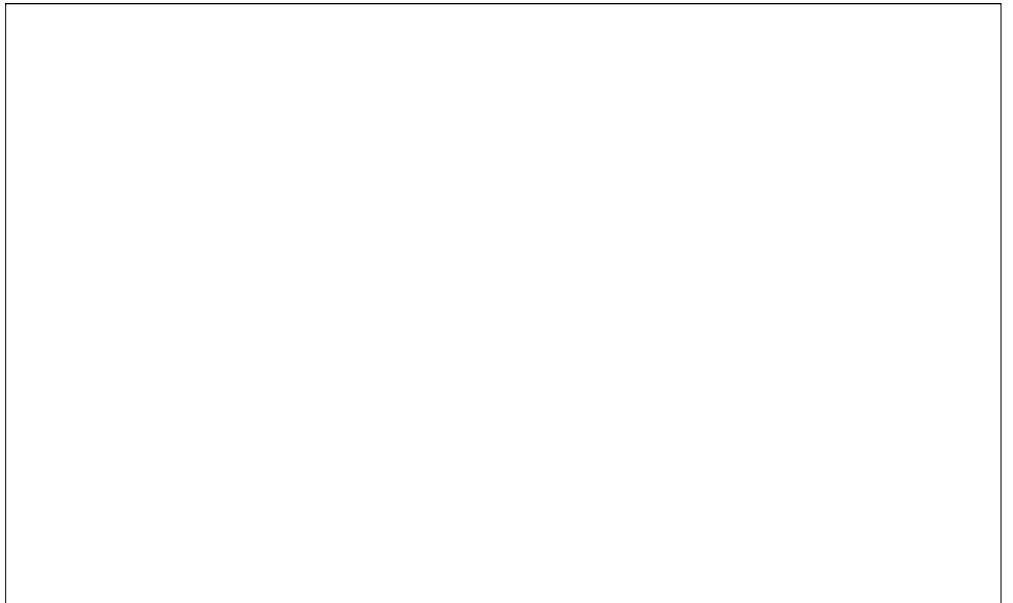
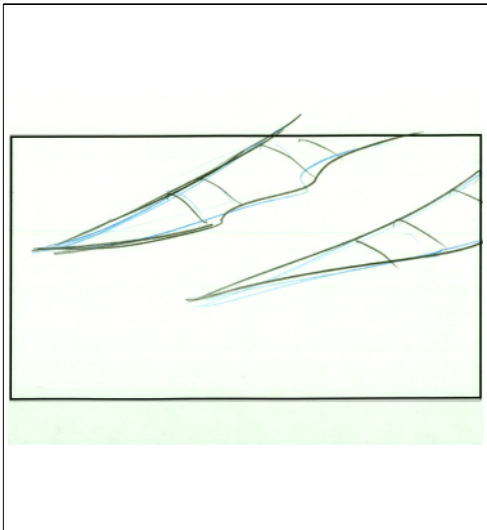

Seq	Scene	Panel
27	978	1

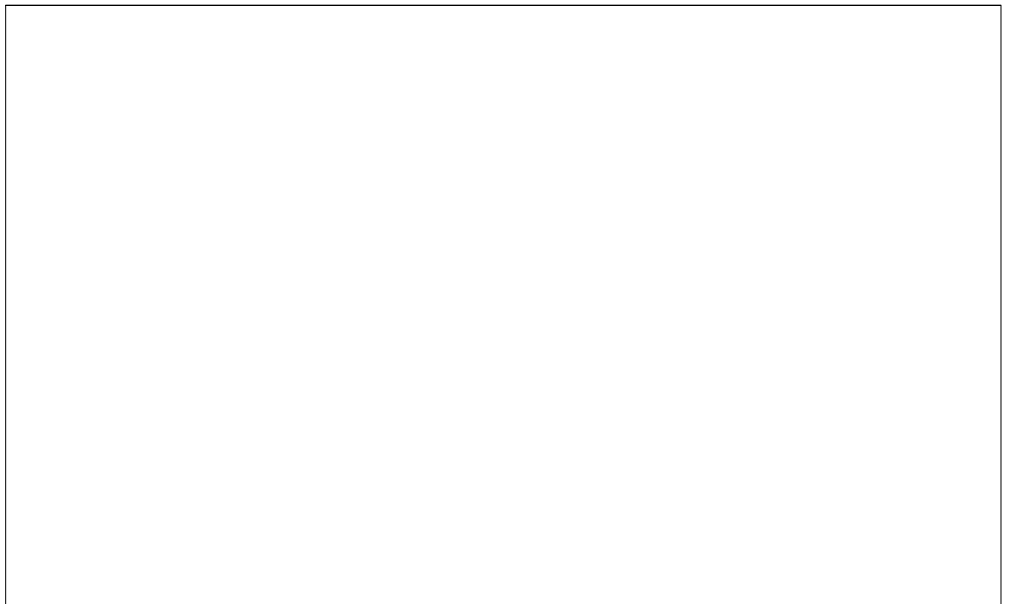

Seq	Scene	Panel
27	979	1

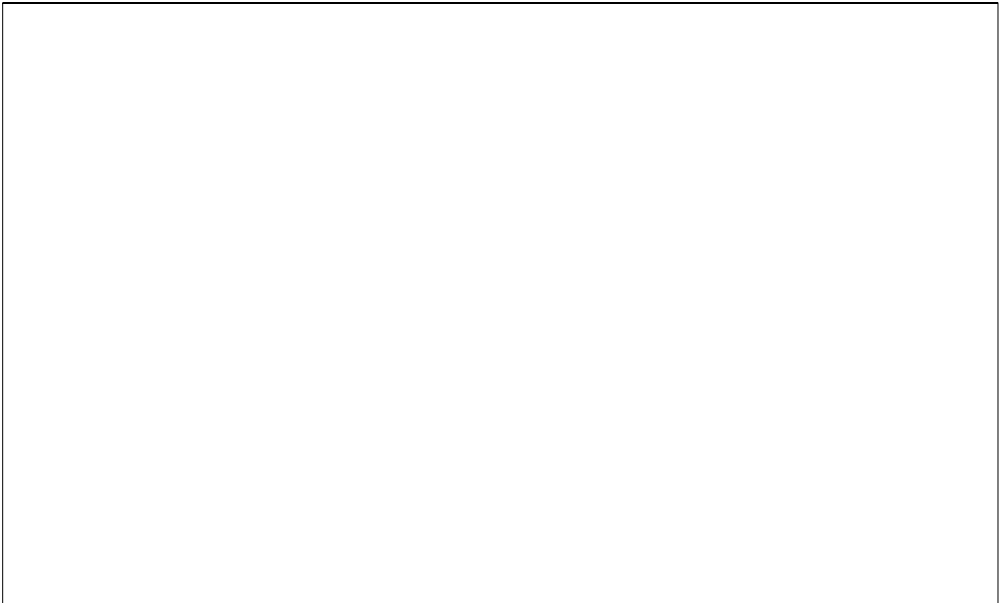
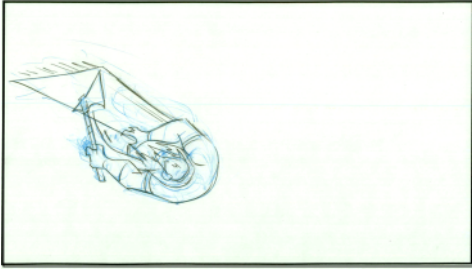

Seq	Scene	Panel
27	979	2

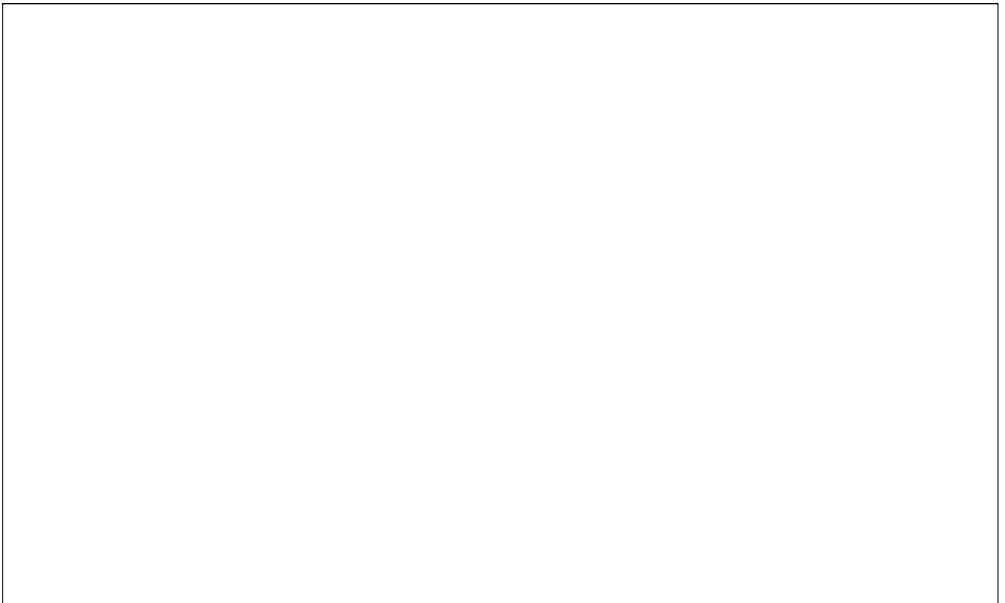
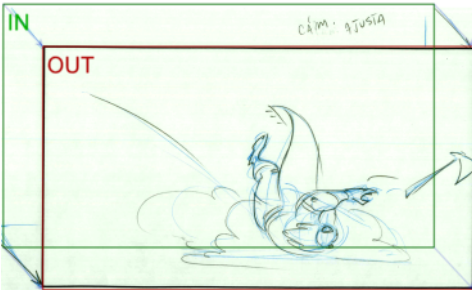

Seq	Scene	Panel
27	979	3

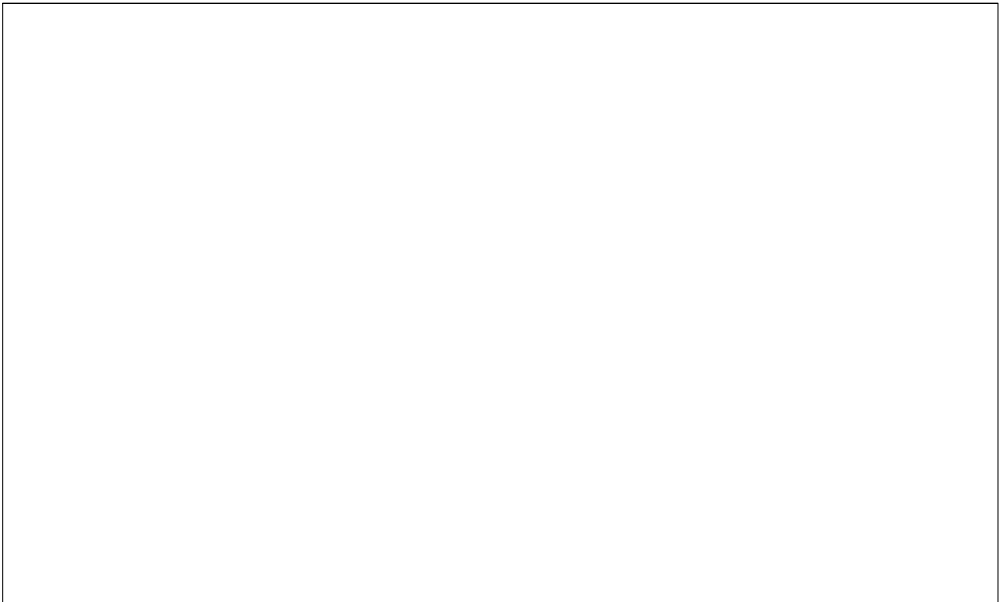

Seq	Scene	Panel
27	979	4

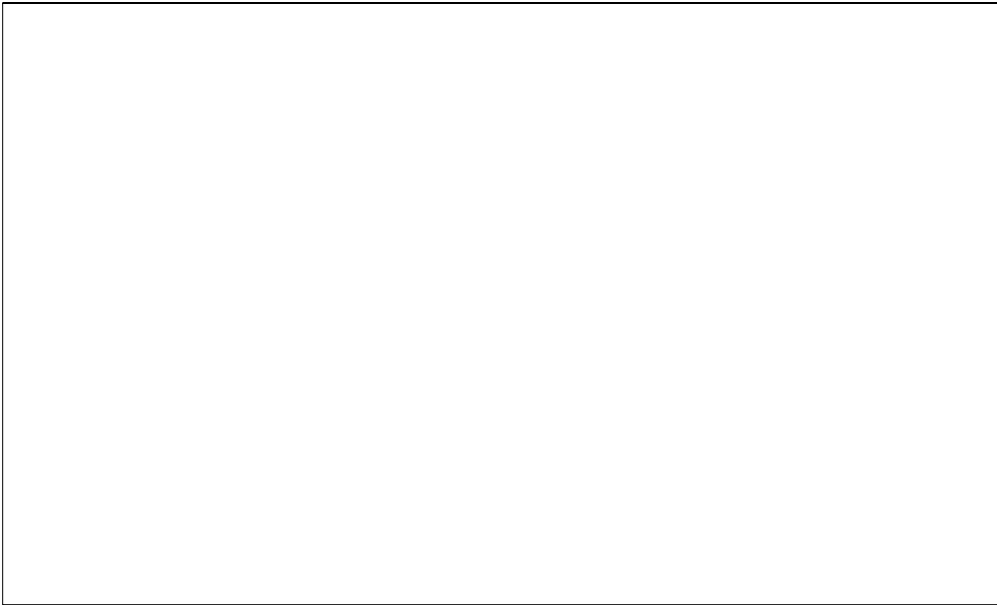

Seq	Scene	Panel
27	980	1

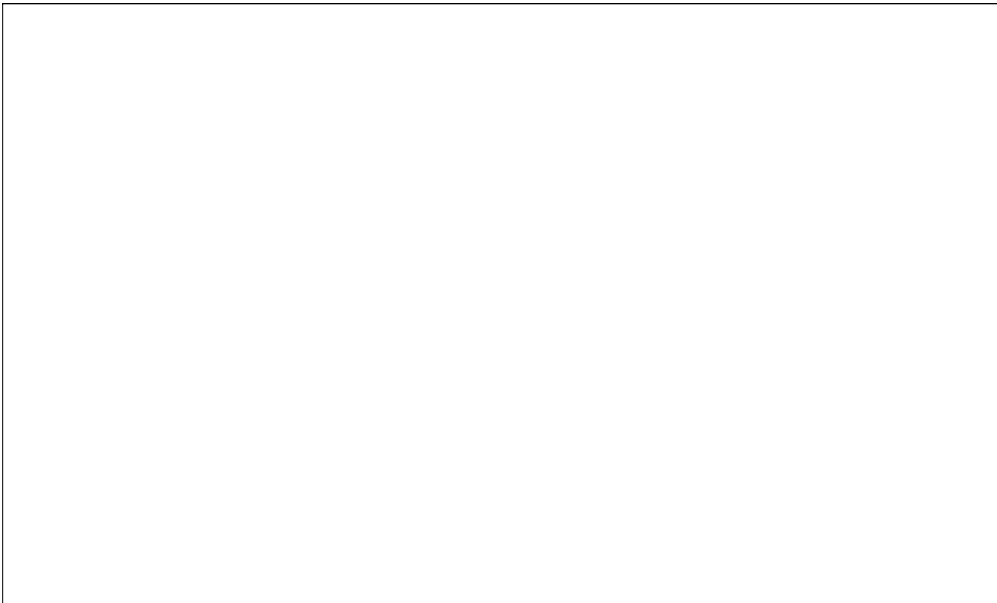
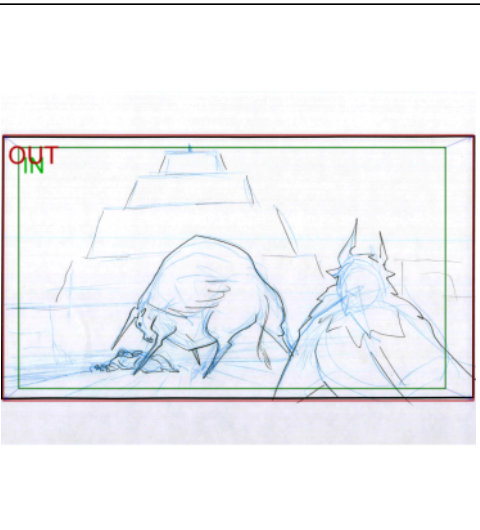

Seq	Scene	Panel
27	981	1

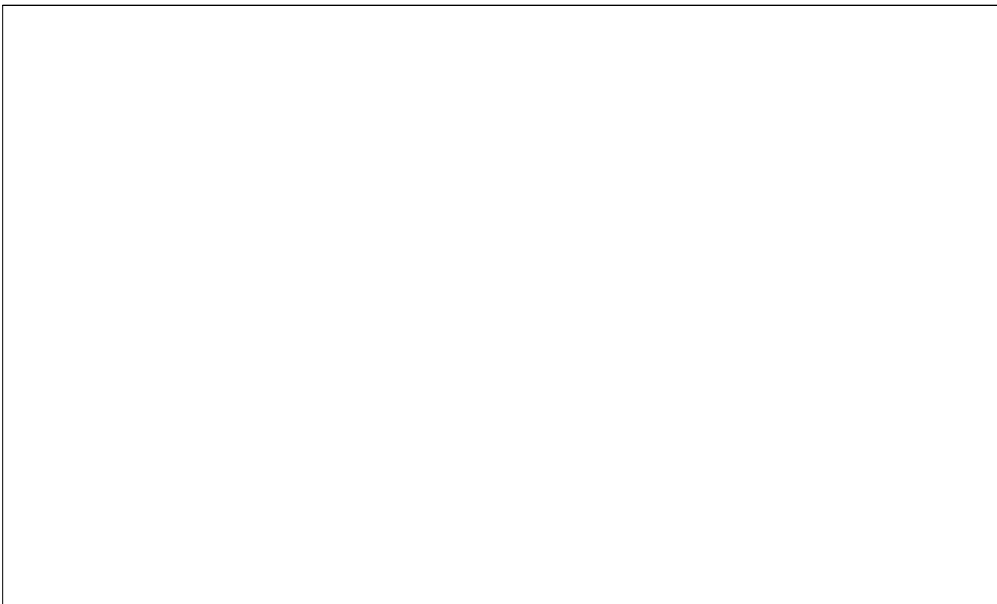

Seq	Scene	Panel
27	982	1

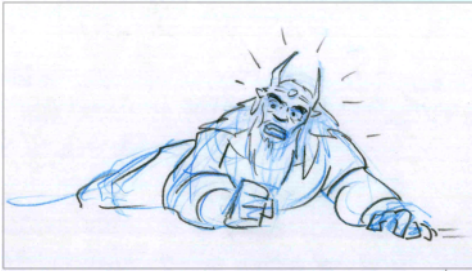

Seq	Scene	Panel
27	983	1



Seq	Scene	Panel
27	984	1



Seq	Scene	Panel
27	984	2

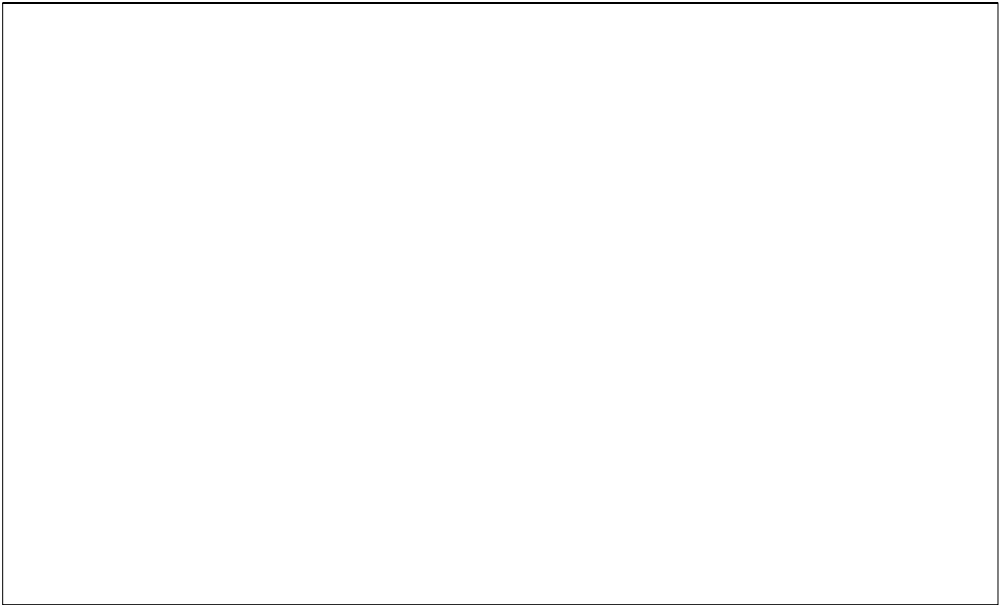
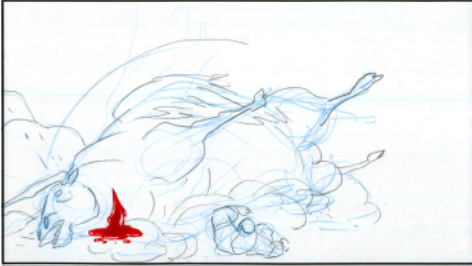

Seq	Scene	Panel
27	985	1

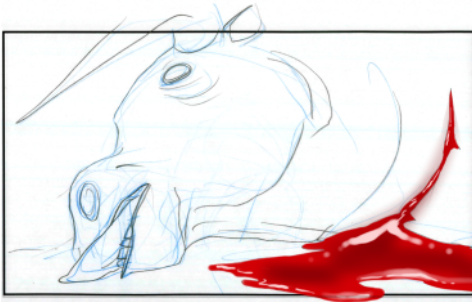

Seq	Scene	Panel
27	986	1

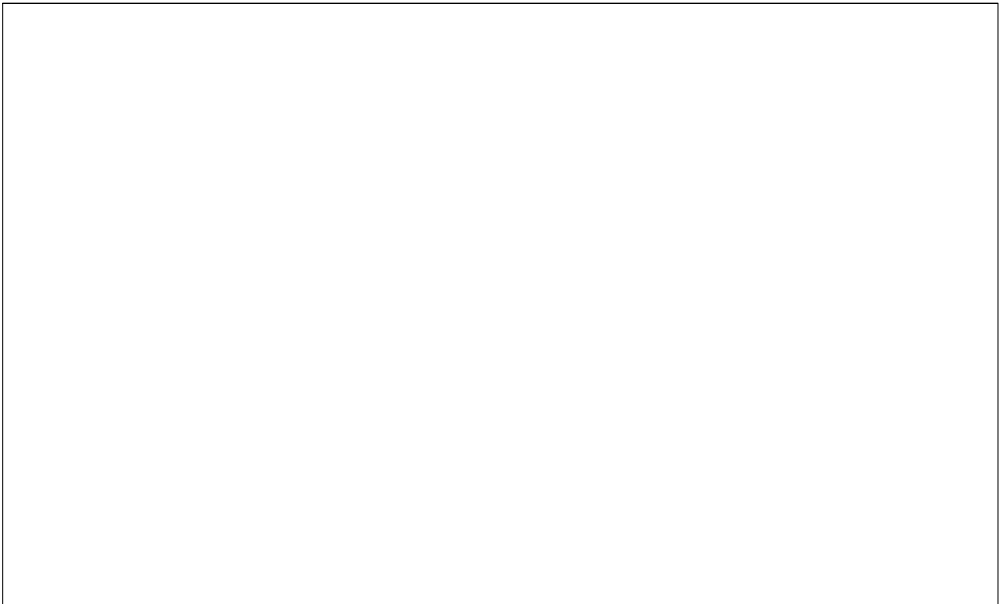
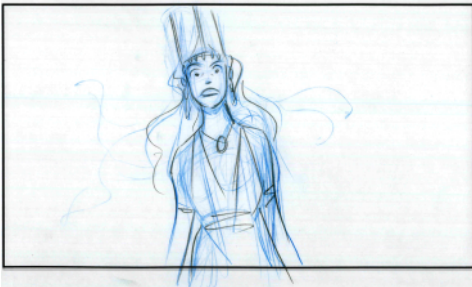

Seq	Scene	Panel
27	986	2

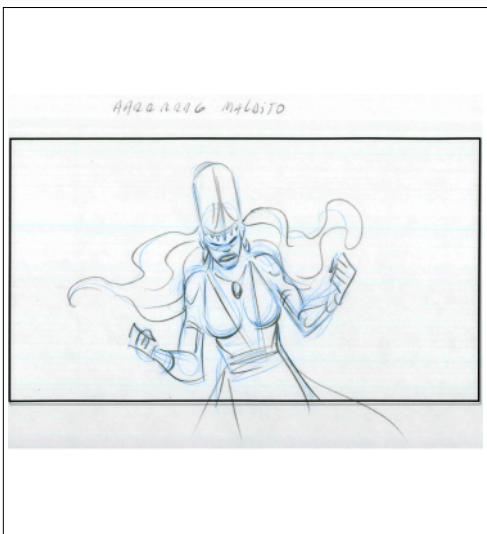

Dialog
Ishtar: Aaarrrrrg! Maldito

Seq	Scene	Panel
27	986	3

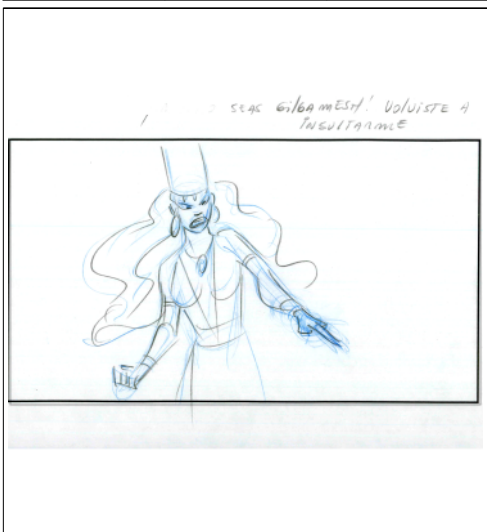

Dialog
Ishtar: seas Gilgamesh! Volviste a insultarme

Seq	Scene	Panel
27	987	1

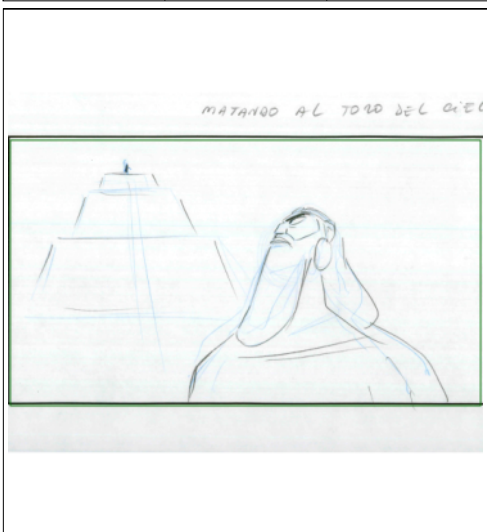

Dialog
Ishtar: Volviste a insultarme matando al Toro del Cielo!

Seq	Scene	Panel
27	987	2

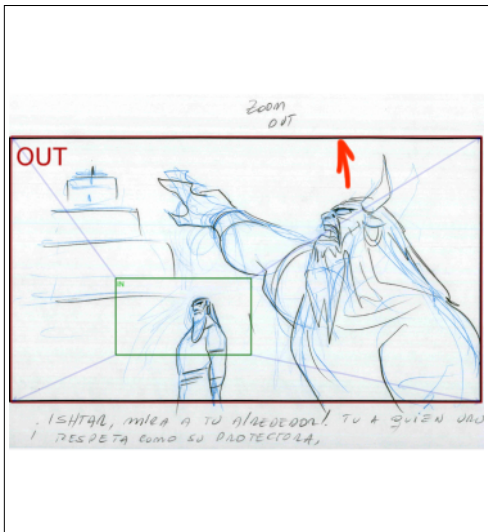

Dialog

Enkidu: Ishtar, mira a tu alrededor! Tu a quien Uruk respeta como su protectora,

Seq	Scene	Panel
27	988	1

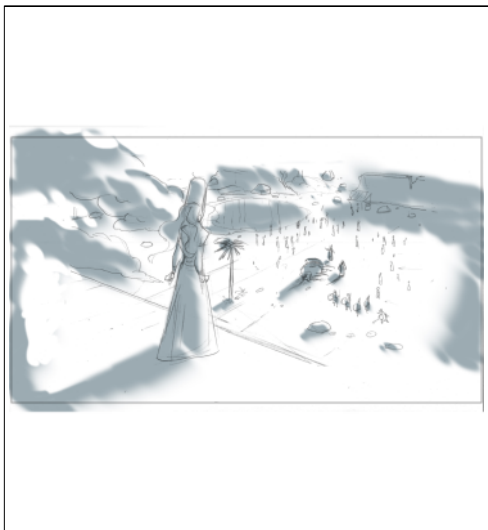

Dialog

Enkidu: Tu a quien Uruk respeta como su protectora, causaste esta destrucción. Y todo por tu orgullo de hembra en celo.

Seq	Scene	Panel
27	989	1

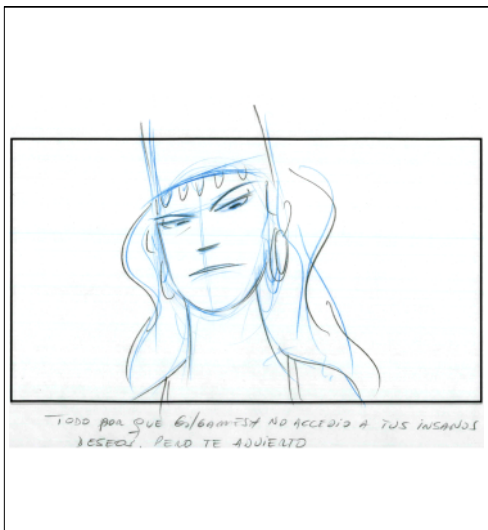

Dialog

Enkidu: Y todo por tu orgullo de hembra en celo. Todo por que Gilgamesh no accedió a tus insanos deseos. Pero te advierto

Seq	Scene	Panel
27	990	1

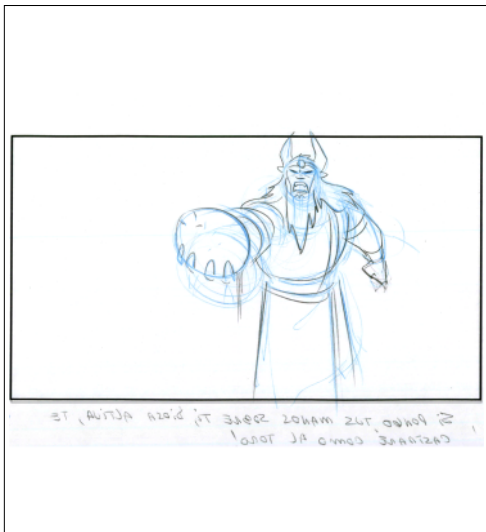

Dialog

Enkidu: Pero te advierto, si pongo mis manos sobre ti, diosa altiva, te castrare como al toro!

Seq	Scene	Panel
27	991	1

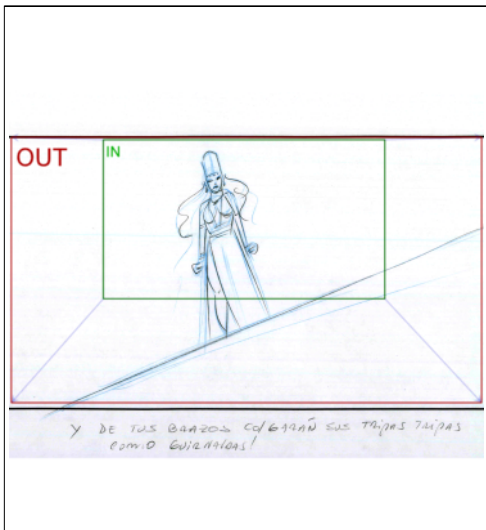

Dialog

Enkidu: Y de tus brazos colgarán sus tripas como girnaldas!

Seq	Scene	Panel
27	991	2

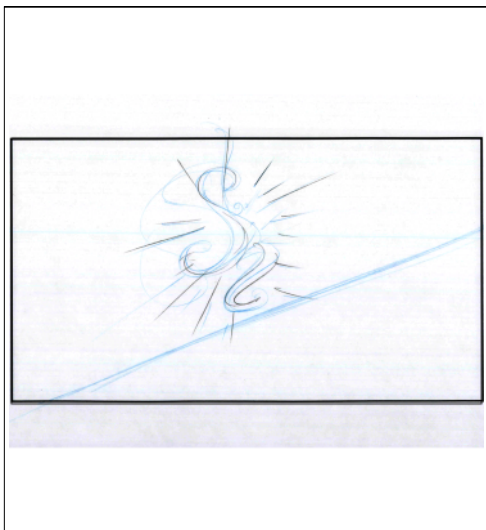

Seq	Scene	Panel
27	992	1



Seq	Scene	Panel
27	993	1

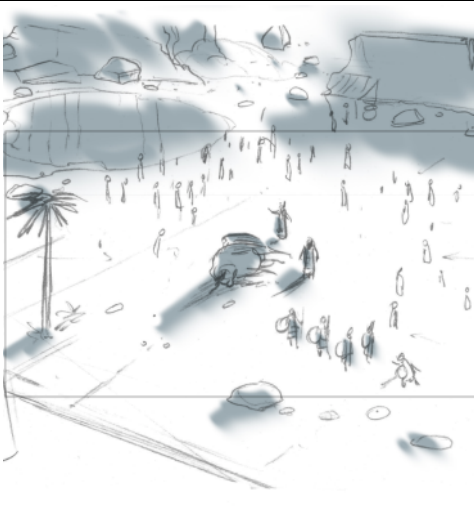

Seq	Scene	Panel
28	994	1

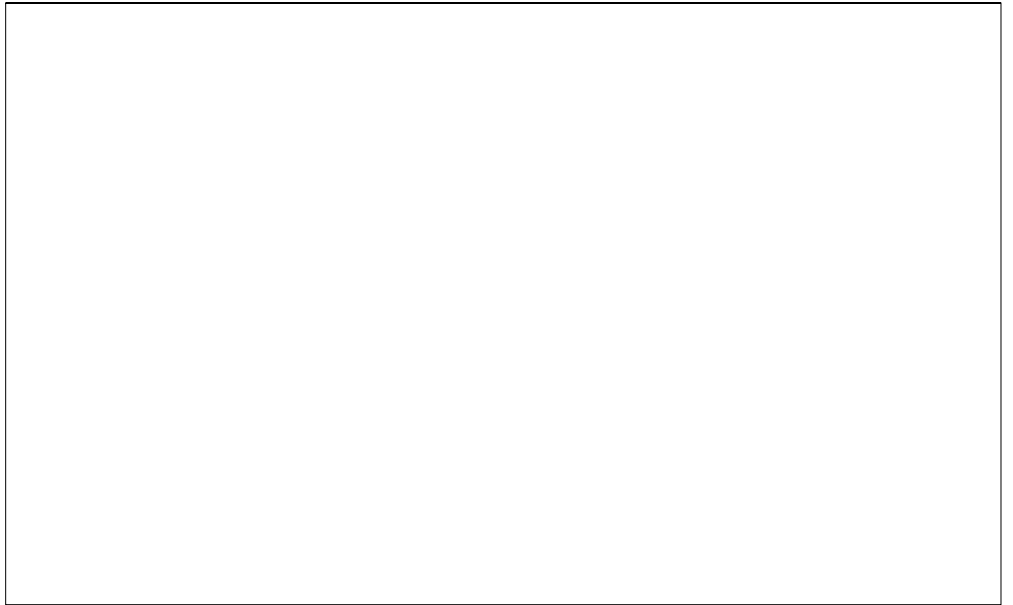
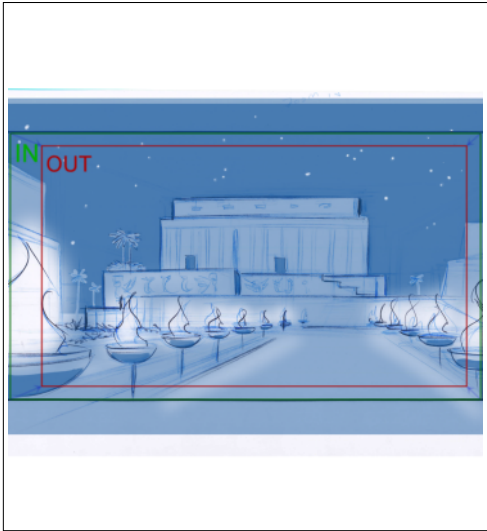

Seq	Scene	Panel
28	995	1

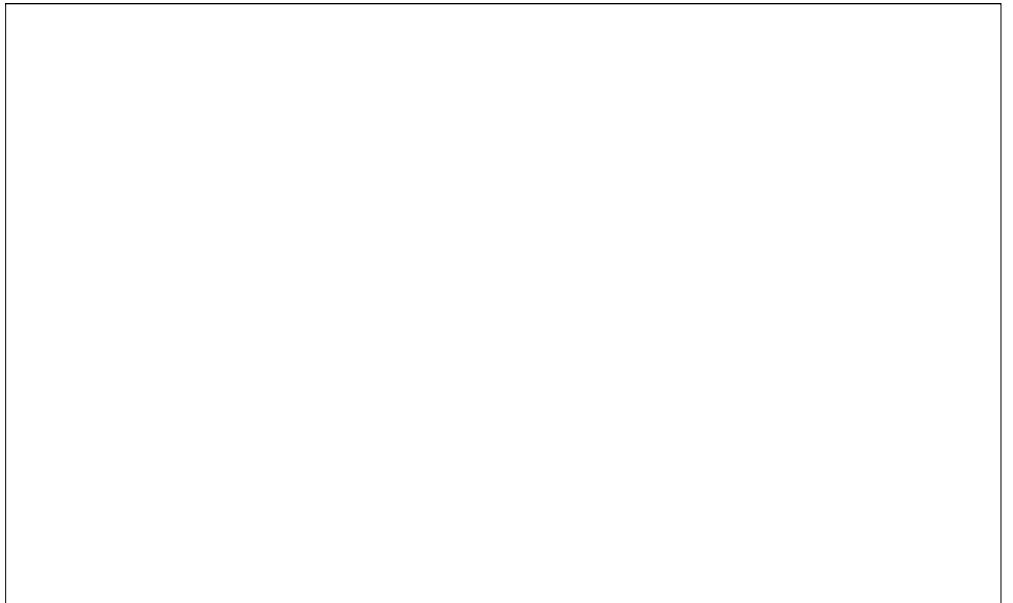
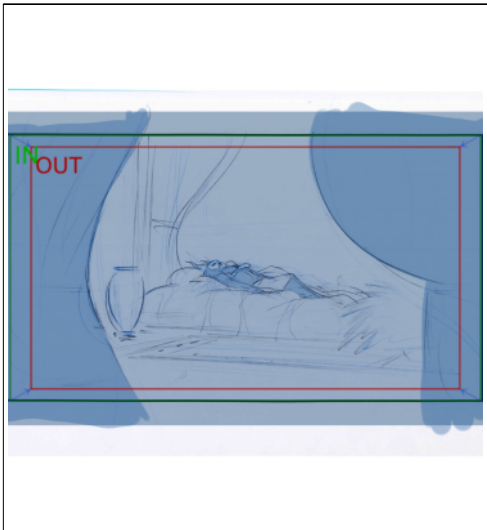

Seq	Scene	Panel
28	996	1

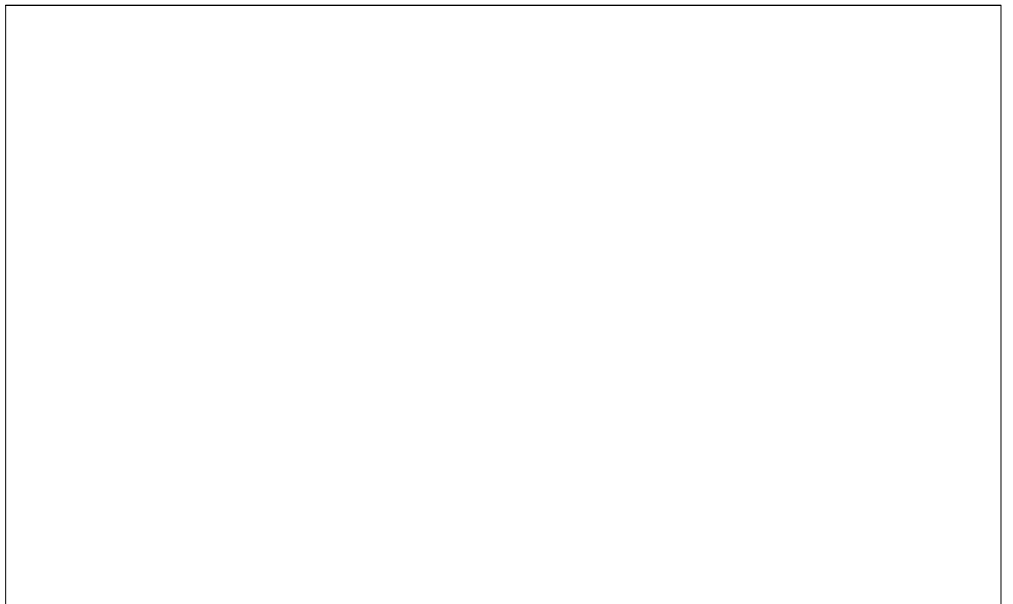
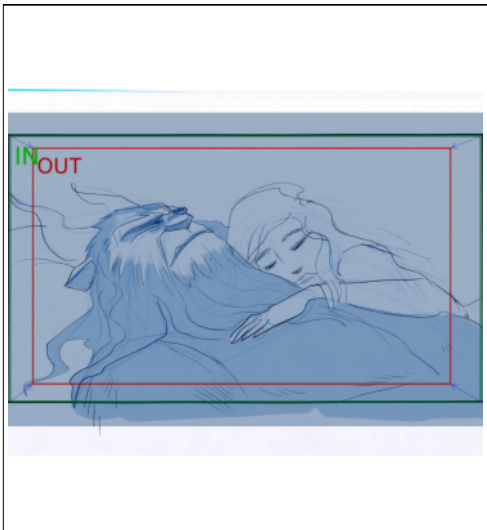

Seq	Scene	Panel
28	997	1

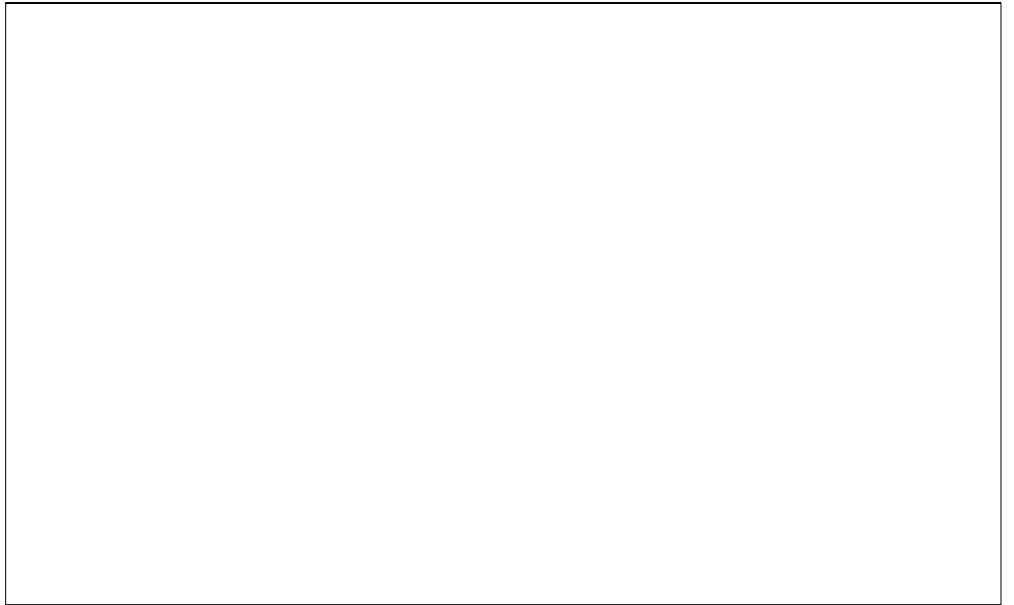
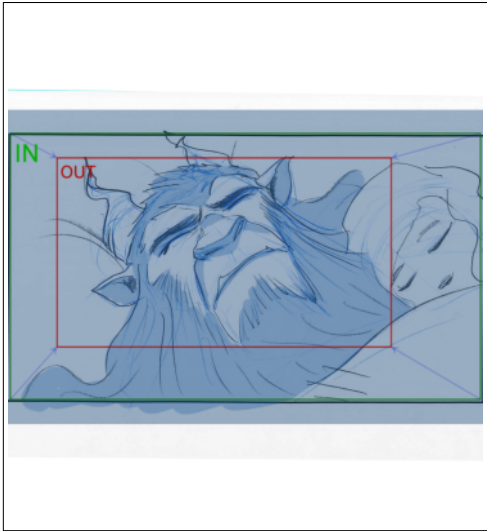

Seq	Scene	Panel
28	997	2

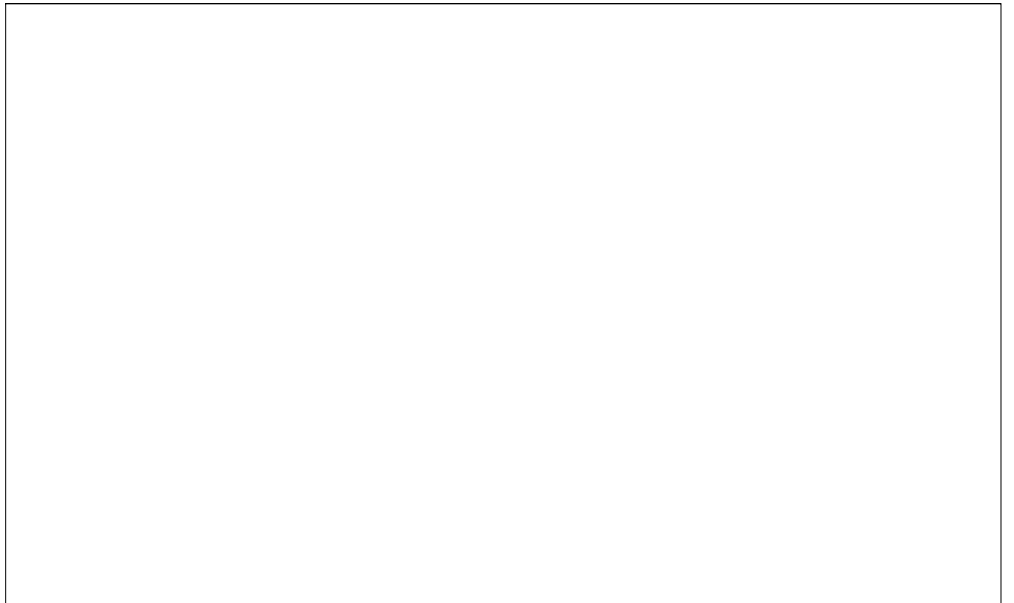
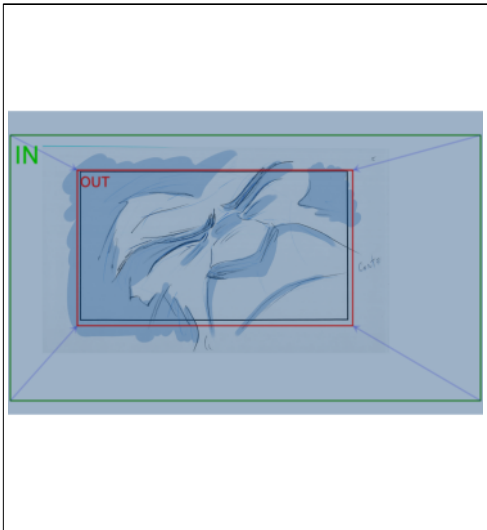

Seq	Scene	Panel
28	997	3

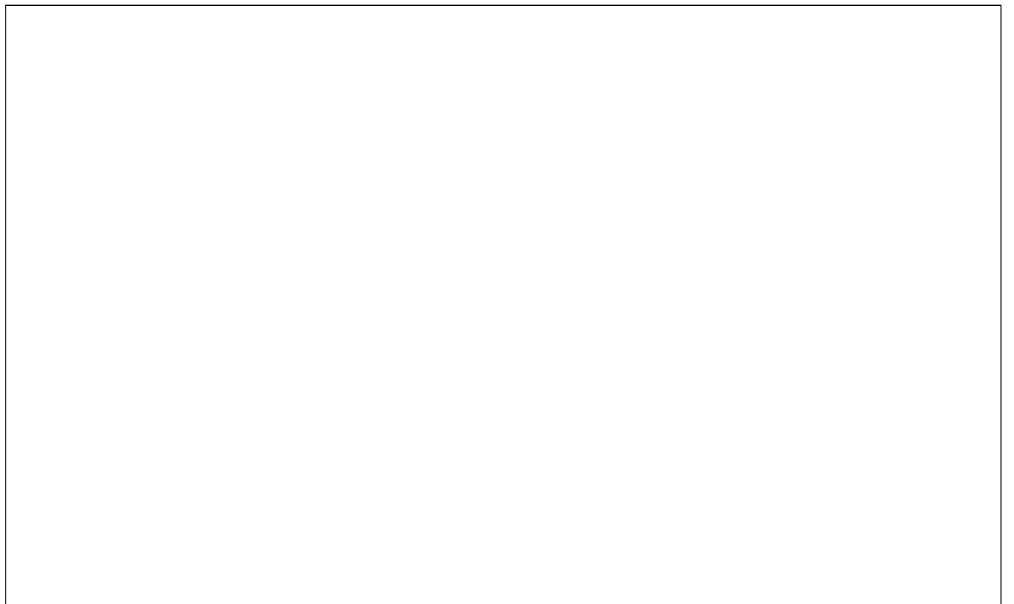
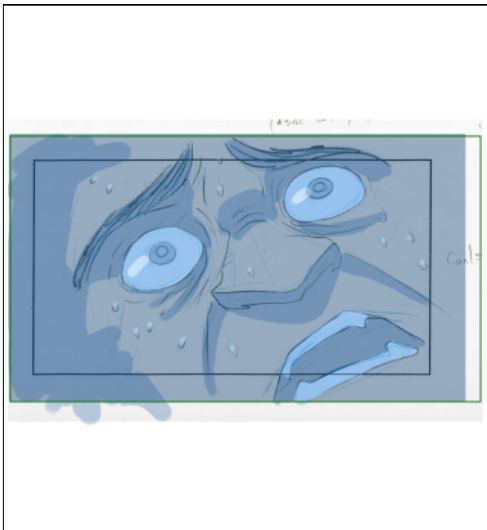

Seq	Scene	Panel
28	998	1

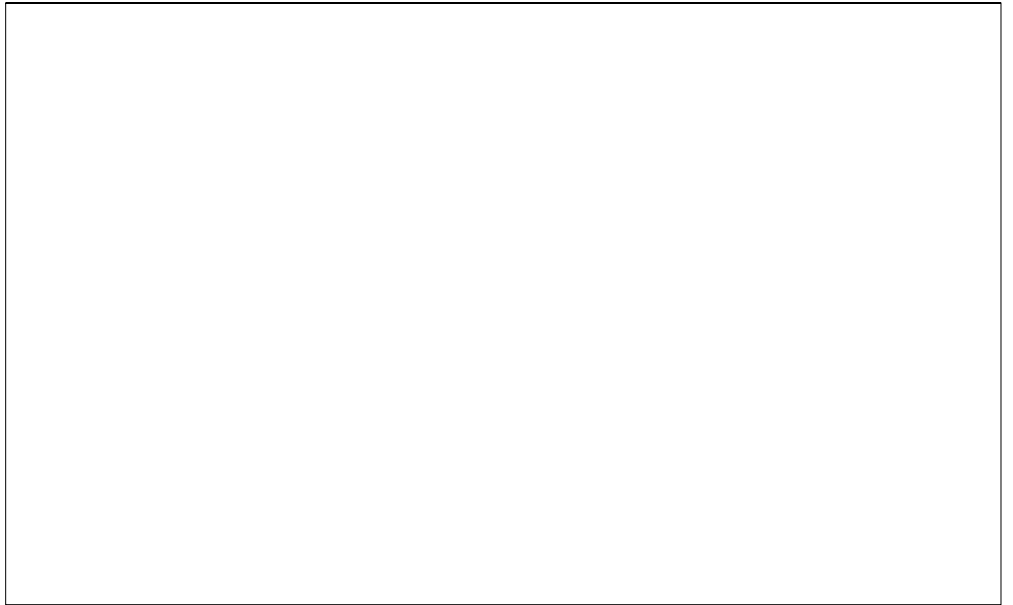
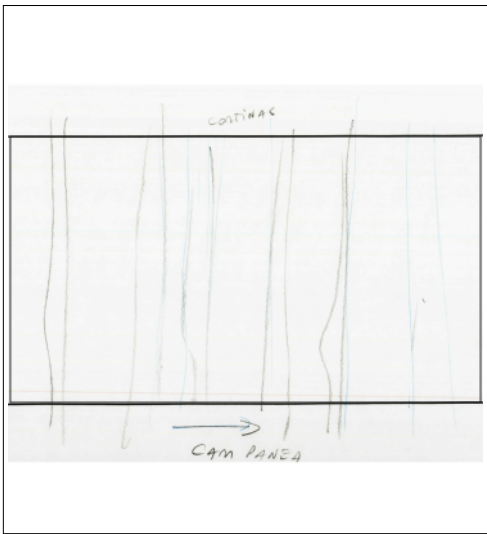

Seq	Scene	Panel
28	998	2

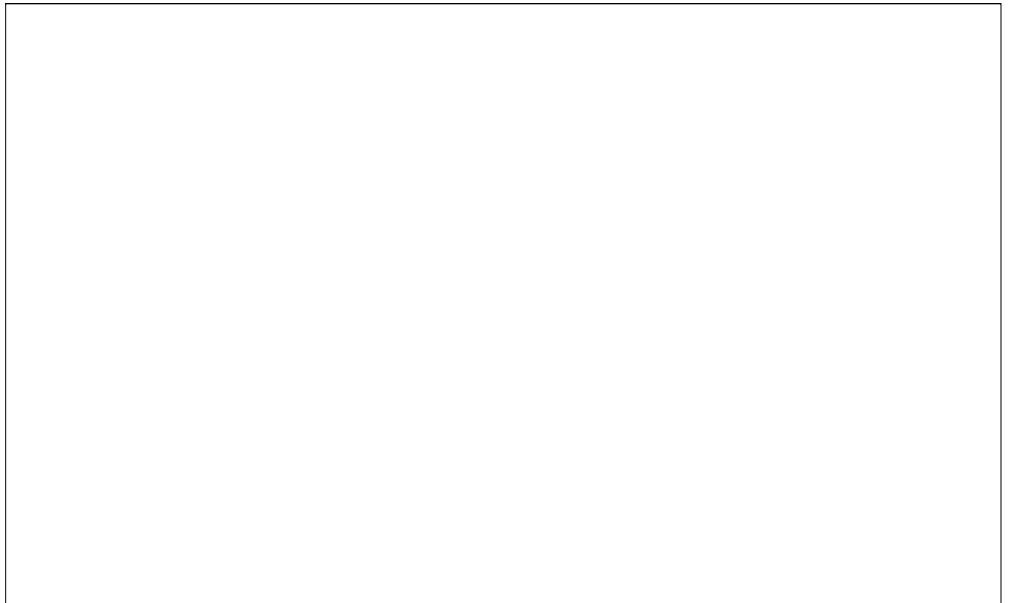
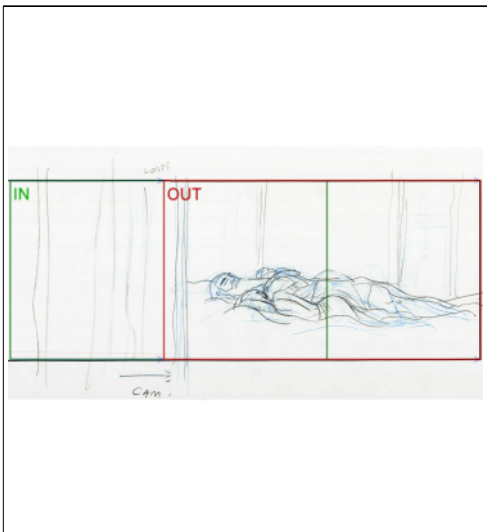

Seq	Scene	Panel
28	999	1

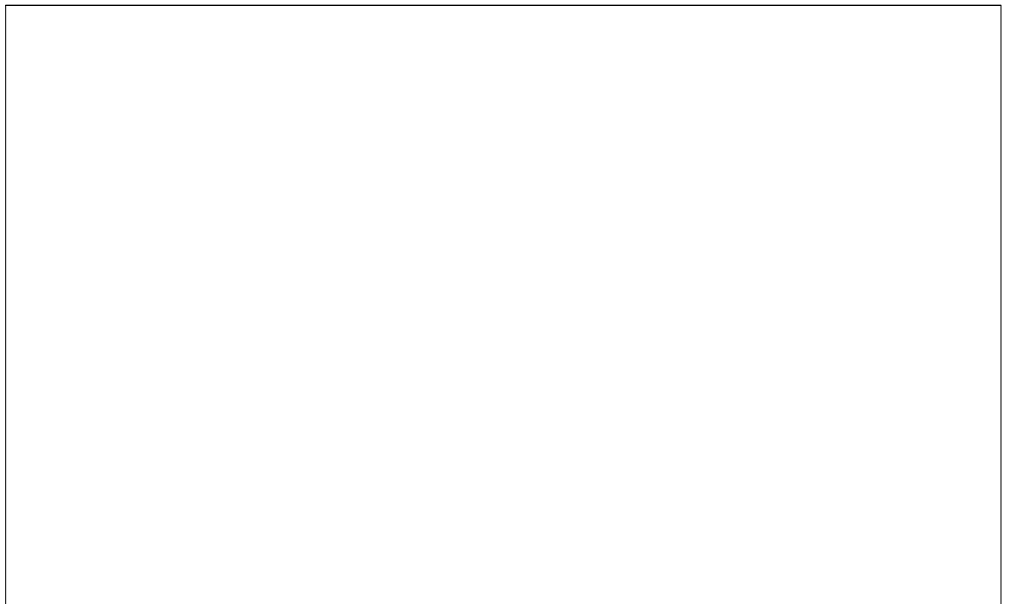
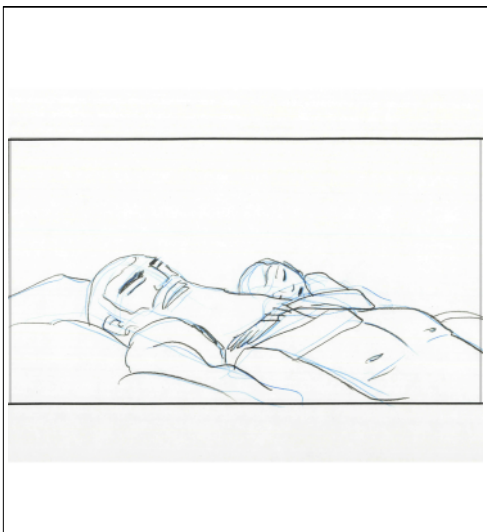

Seq	Scene	Panel
28	999	2

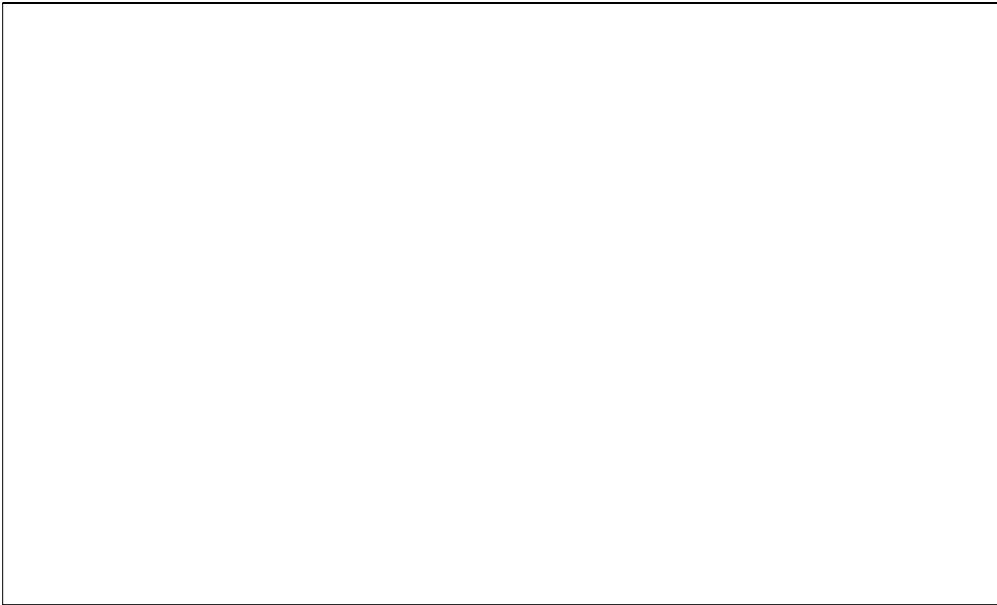

Seq	Scene	Panel
28	1000	1

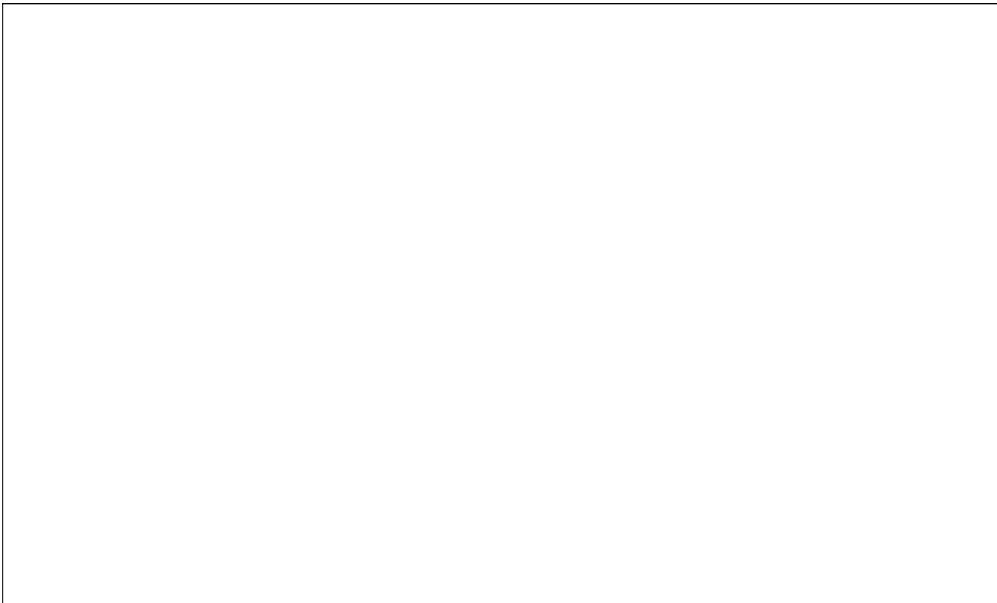

Seq	Scene	Panel
28	1001	1

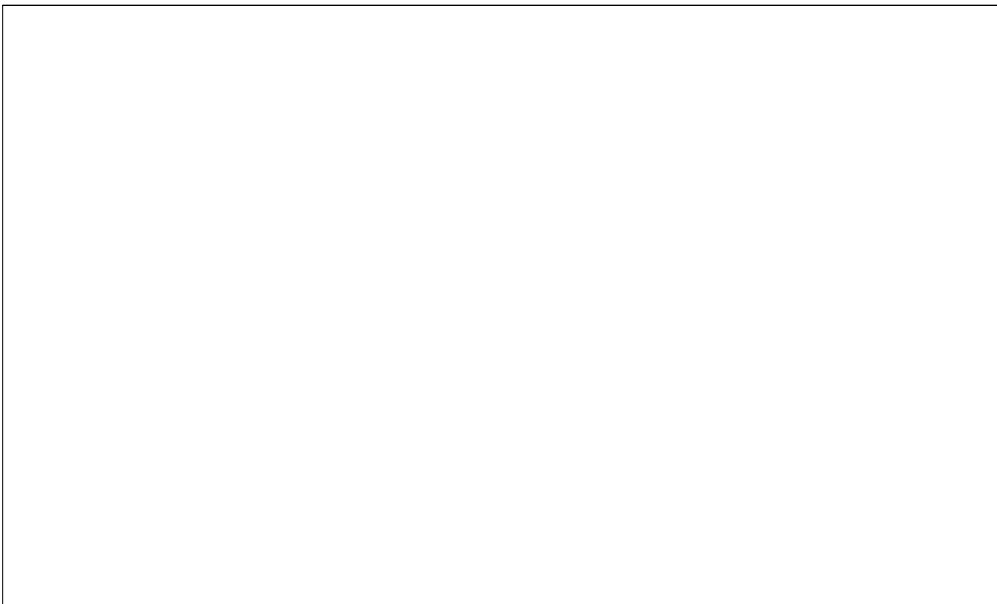

Seq	Scene	Panel
28	1001	2

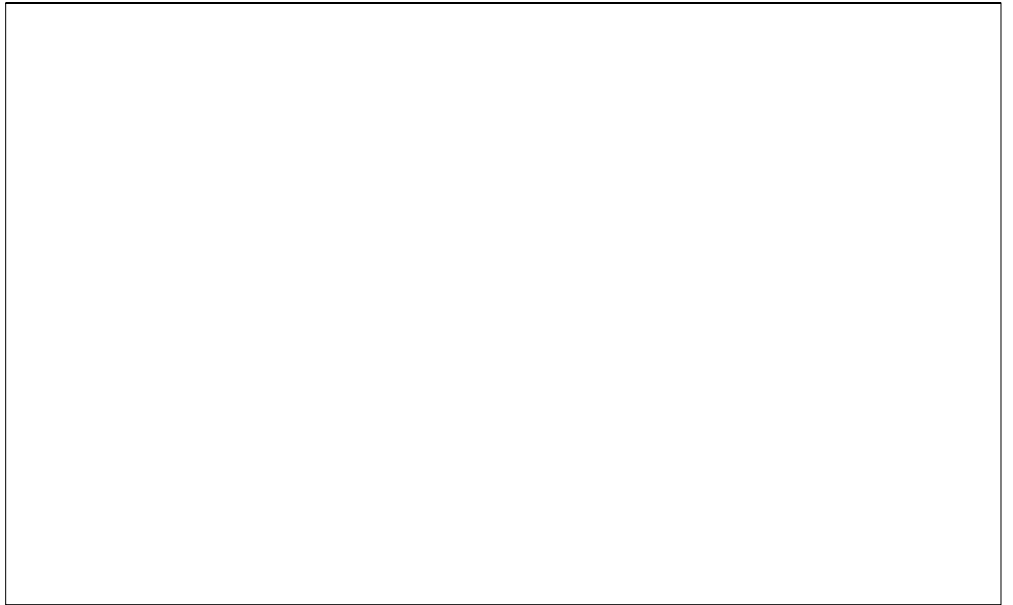
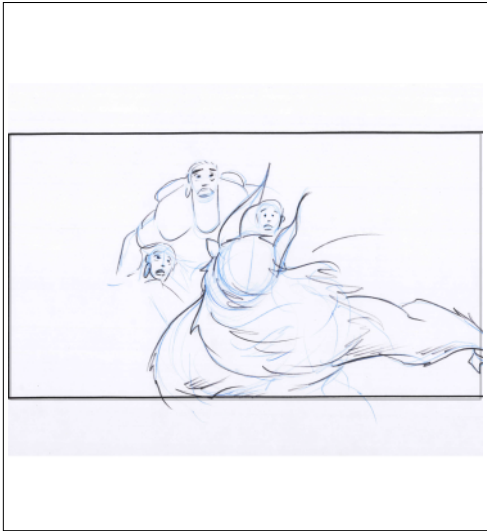

Seq	Scene	Panel
28	1002	1

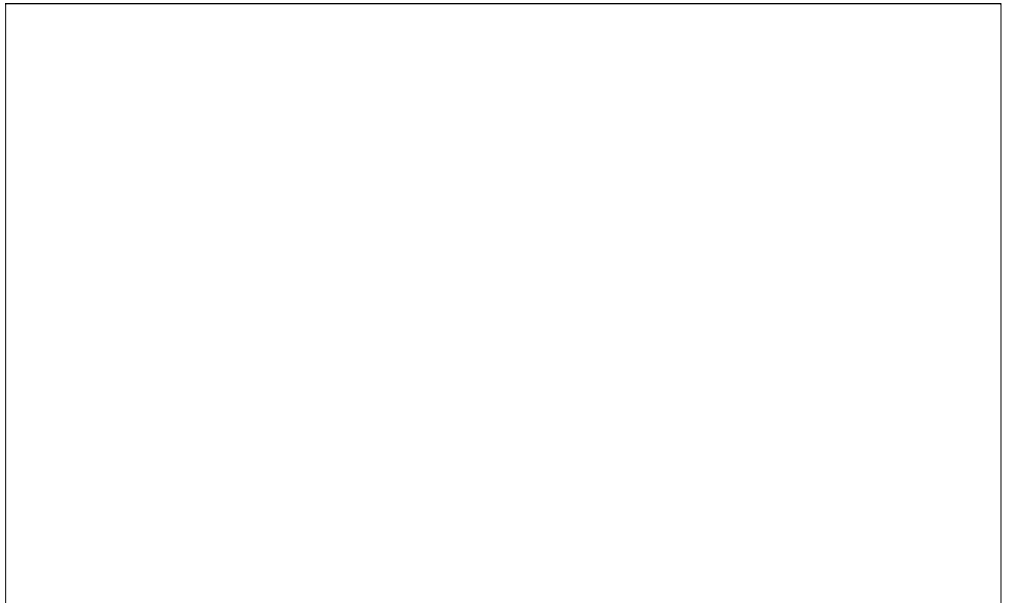
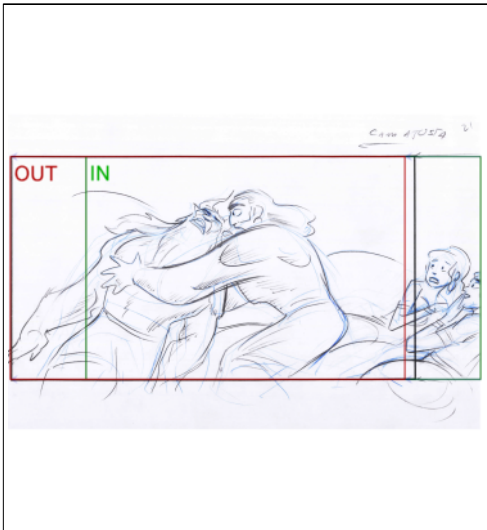

Seq	Scene	Panel
28	1002	2

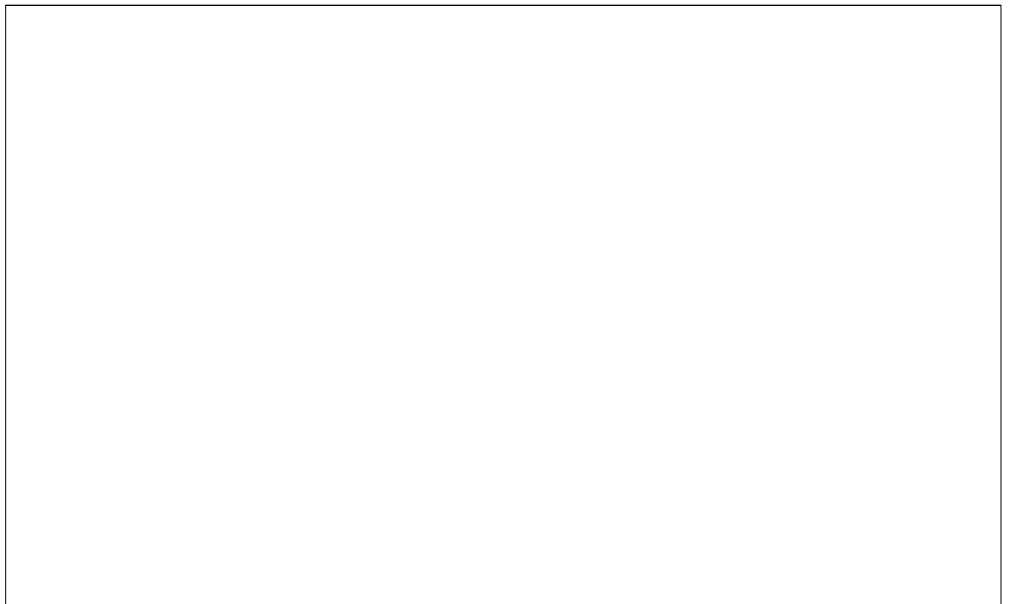

Seq	Scene	Panel
28	1003	1

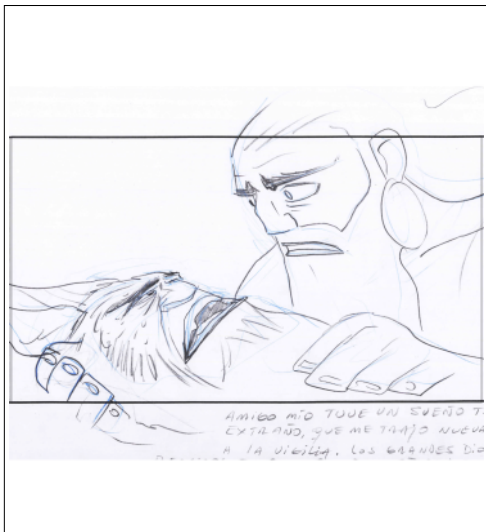

Dialog

GILGAMESH:
"ENKIDU, QUÉ SUCEDE?"

ENKIDU:
"DURANTE LA NOCHE TUVE UN SUEÑO. LOS CIELOS GEMÍAN GILGAMESH, Y LA TIERRA SE RESQUEBRAJABA."

Seq	Scene	Panel
28	1004	1



Dialog

Enkidu (voz en off, agitada, cansada): Yo estaba solo frente a una criatura de rostro siniestro, como el monstruo maléfico de la tormenta,

Seq	Scene	Panel
28	1005	1

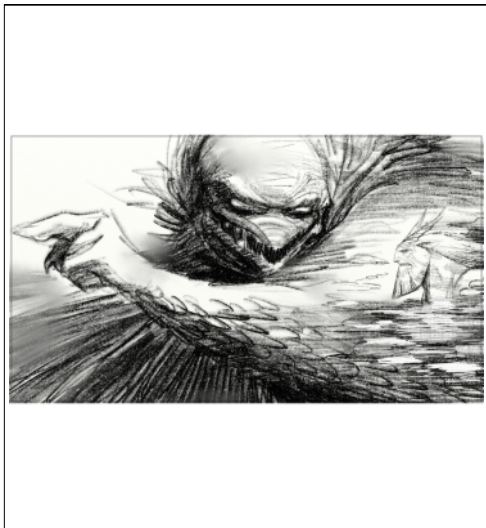

Dialog

Enkidu (voz en off, agitada, cansada): Y me decía: "¡Sígueme a la mansión de los moradores a quienes les falta la luz y en lugar de pan comen barro!"

Seq	Scene	Panel
28	1006	1



Dialog

Enkidu (voz en off, agitada, cansada): Entonces, cayó sobre mí. Y con sus garras de águila estranguló mi cuello hasta que todo fue negro...

Seq	Scene	Panel
28	1006	2

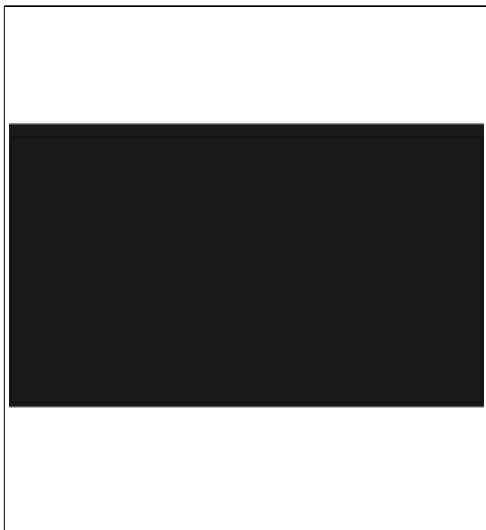

Dialog

"¡Sálvame, amigo mío!", decía yo. Pero tú no me salvabas...

Seq	Scene	Panel
28	1007	1



Seq	Scene	Panel
28	1008	1



Dialog

Enkidu Nergal clavó sus ojos en mí

Seq	Scene	Panel
28	1009	1



Dialog

Enkidu (voz en off, agitada, cansada): y me llevó volando al palacio del que nadie que entró, salió.

Seq	Scene	Panel
28	1010	1



Dialog

En ese reino de polvo, vi a los reyes despojados de sus coronas. Los sacerdotes que habían ocupado en la Tierra el lugar de los dioses, ahora eran sirvientes:

Seq	Scene	Panel
28	1011	1

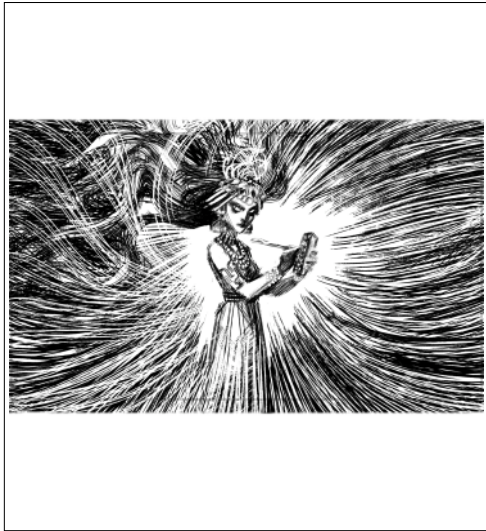

Dialog

Y FINALMENTE, VI A LA REINA DE LOS INFIERNOS, LA DIOSA ERESHKIGAL, QUE LEÍA LO ESCRITO EN UNA TABLILLA.

Seq	Scene	Panel
28	1012	1

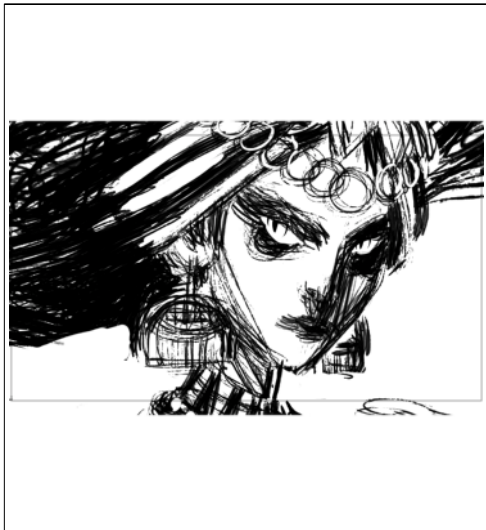

Dialog

LEVANTÓ LA CABEZA, ME MIRÓ, Y GRITÓ:

Seq	Scene	Panel
28	1012	2

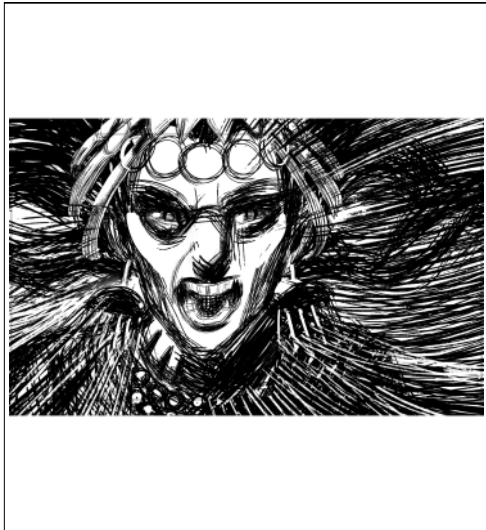

Dialog

¿QUIÉN TE TRAJO HASTA AQUÍ?

Seq	Scene	Panel
28	1013	1

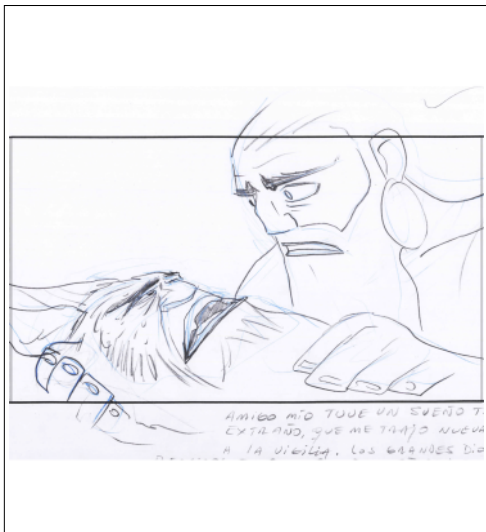

Dialog

ENKIDU:

"ME TEMO, QUE ENLIL, DECRETÓ MI MUERTE."

Seq	Scene	Panel
28	1013	2

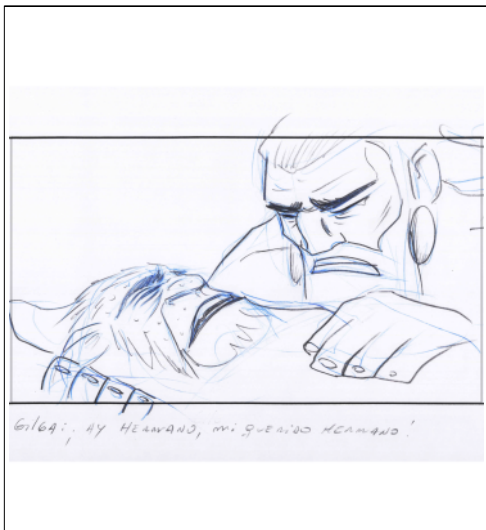

Dialog

Gilgamesh: Ay hermano, mi querido hermano!

Seq	Scene	Panel
28	1014	1



Dialog

Gilgamesh: Por que me dejan y te llevan a tí? Por que me perdonan la vida y se apoderan de la tuya?

Seq	Scene	Panel
28	1015	1



Dialog

Gilgamesh: Tengo que sentarme junto a la puerta de los difuntos, junto al espíritu de los muertos para verte partir?

Seq	Scene	Panel
28	1016	1



Dialog

Enkidu: A ti, puerta sagrada del bosque, te maldigo!

Seq	Scene	Panel
28	1017	1



Dissolve

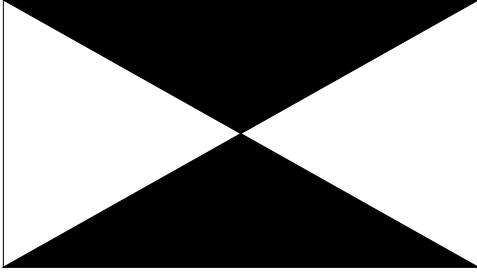

Seq	Scene	Panel
28	1018	1



Dialog
Enkidu (en off): Y al bosque entero! si hubiese sabido que me costarías la vida

Seq	Scene	Panel
28	1019	1

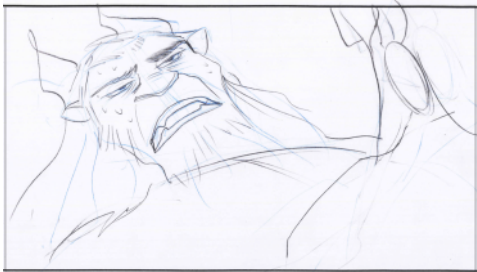

Dialog
Enkidu:
A ti, puerta sagrada del bosque, te maldigo! Y bosque entero! se hubiese sabido que me costaría la vida

Seq	Scene	Panel
28	1019	2



Dialog

Enkidu:

habría alzado el hacha

Seq	Scene	Panel
28	1019	3



Dialog

Enkidu:

y te habría destrozado como a leña podrida!

Seq	Scene	Panel
28	1020	1



Dialog

Gilgamesh: Enkidu... Tú que tienes tan buen juicio, ahora dices disparates? por qué hablas así?

Seq	Scene	Panel
28	1021	1

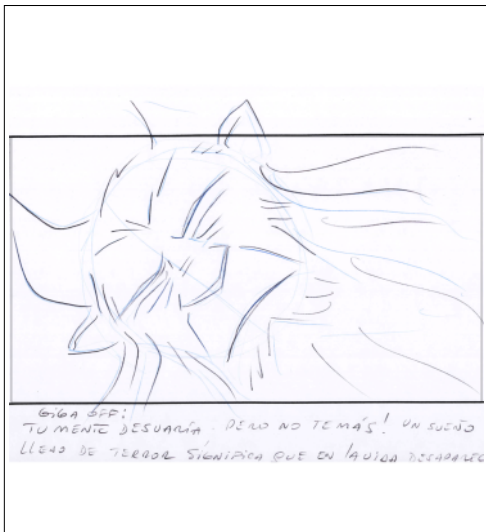

Dialog

Gilgamesh (en off):

Tu mente desvaría. Pero no temas! Un sueño lleno de terror significa que en la vida desaparece la angustia.

Seq	Scene	Panel
28	1022	1



Dialog

Gilgamesh:

Vamos! Pediré auxilio a los grandes dioses, para que Enlil se apiade de ti.

Seq	Scene	Panel
28	1023	1

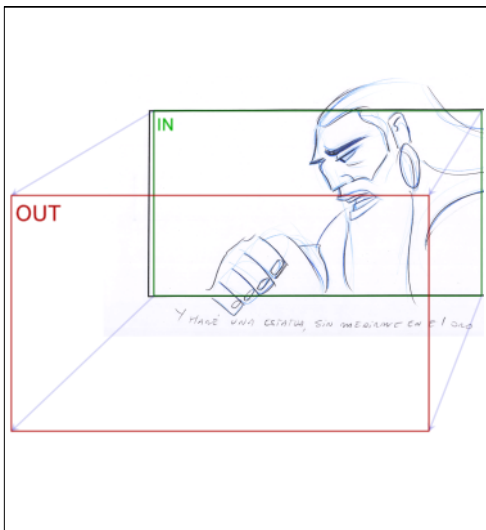

Seq	Scene	Panel
28	1023	2

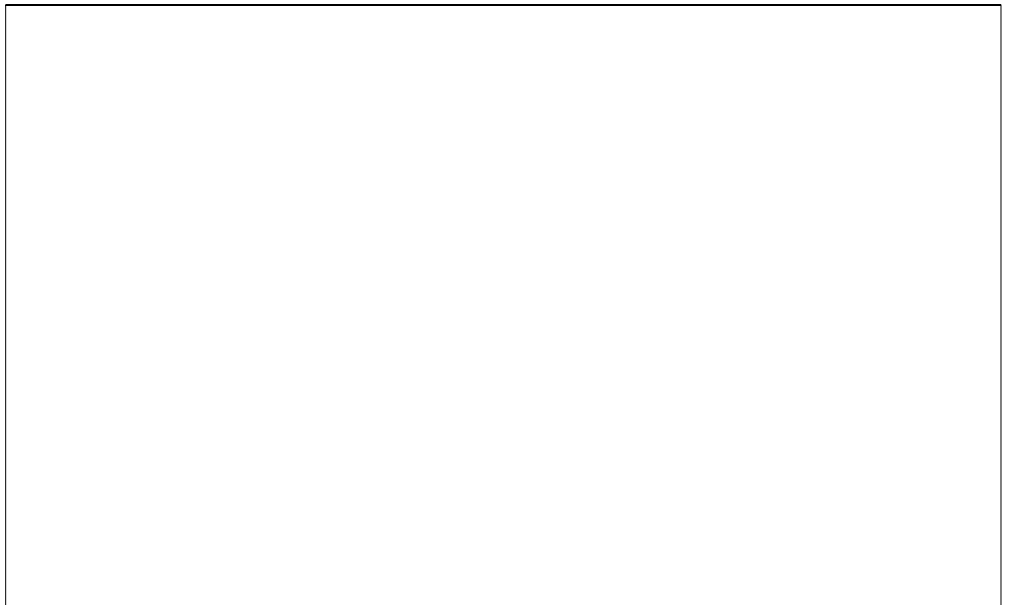
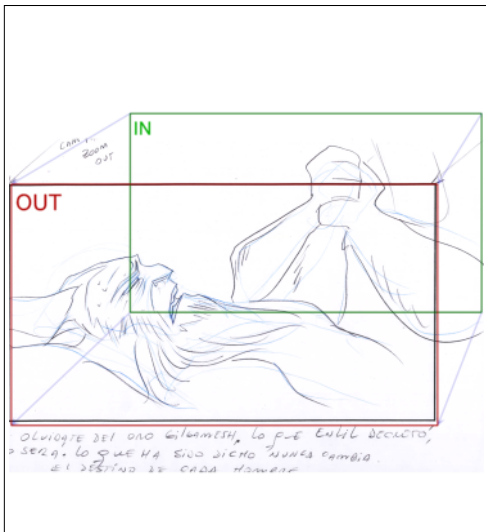

Seq	Scene	Panel
28	1023	3

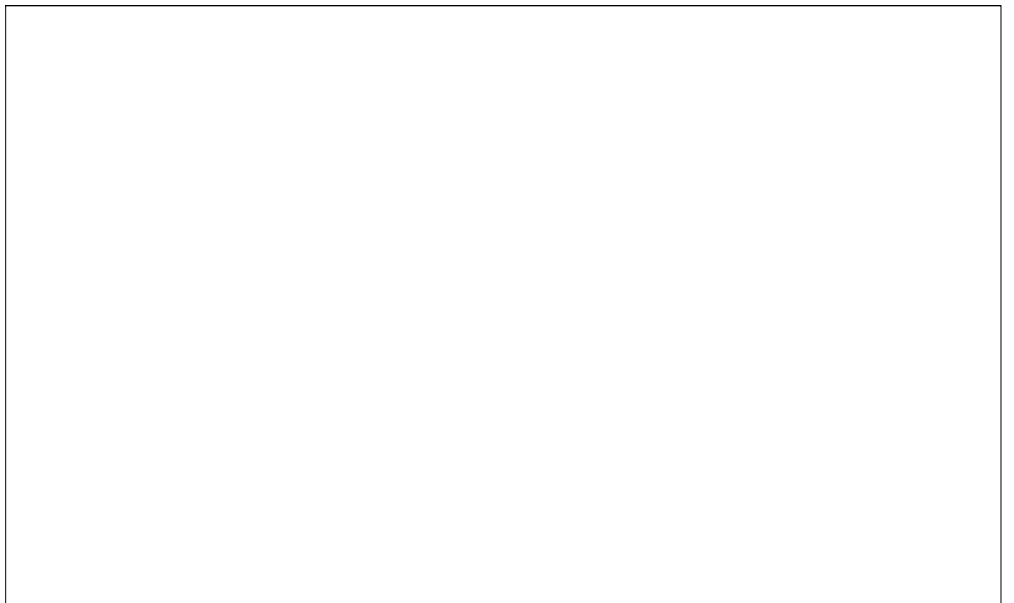

Seq	Scene	Panel
28	1024	1

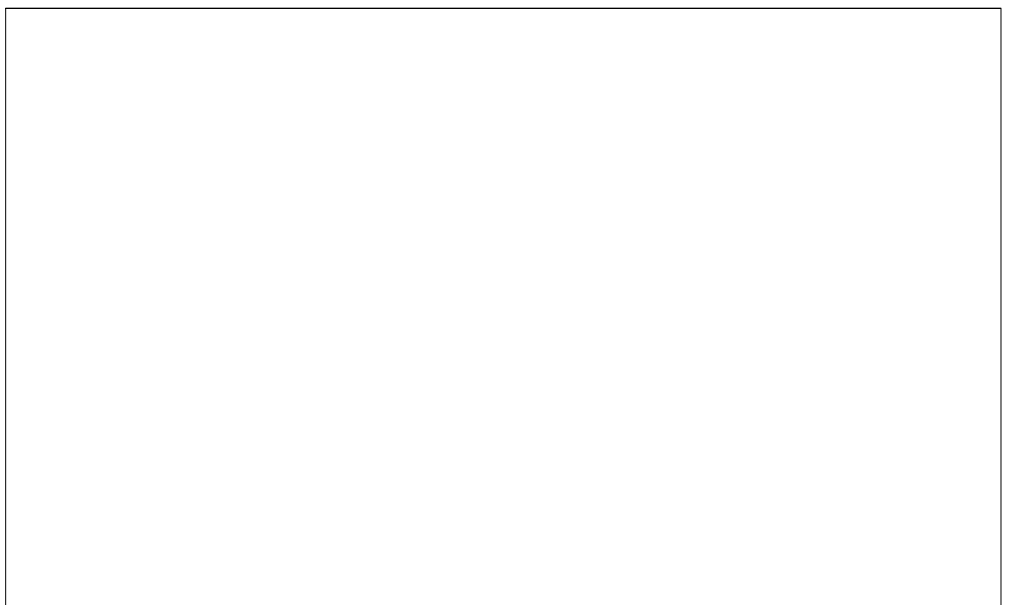
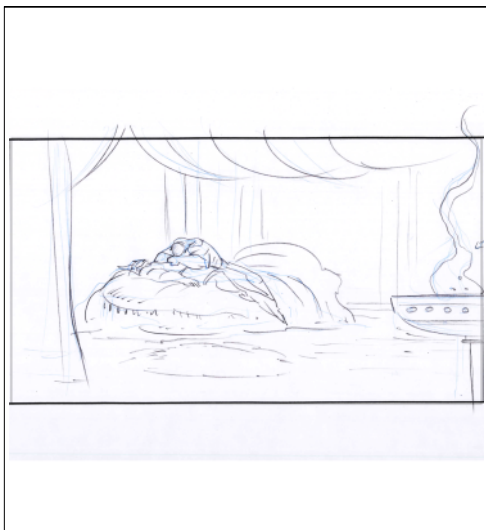



Seq	Scene	Panel
28	1024	2

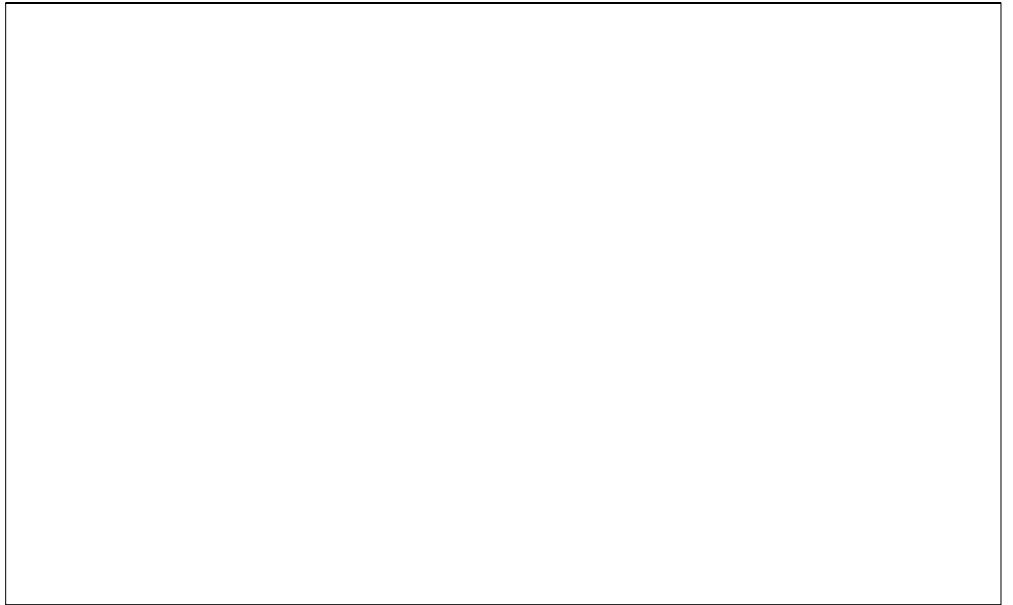
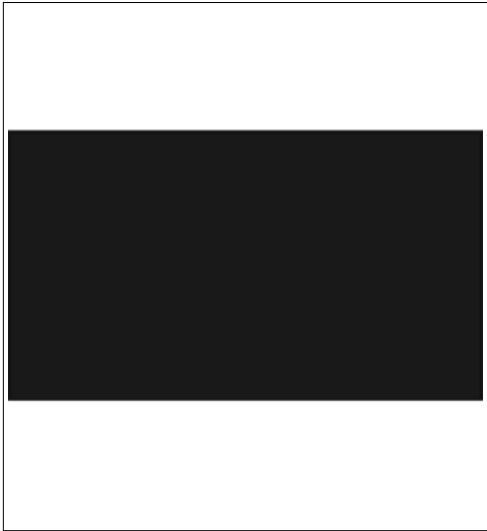

Dissolve

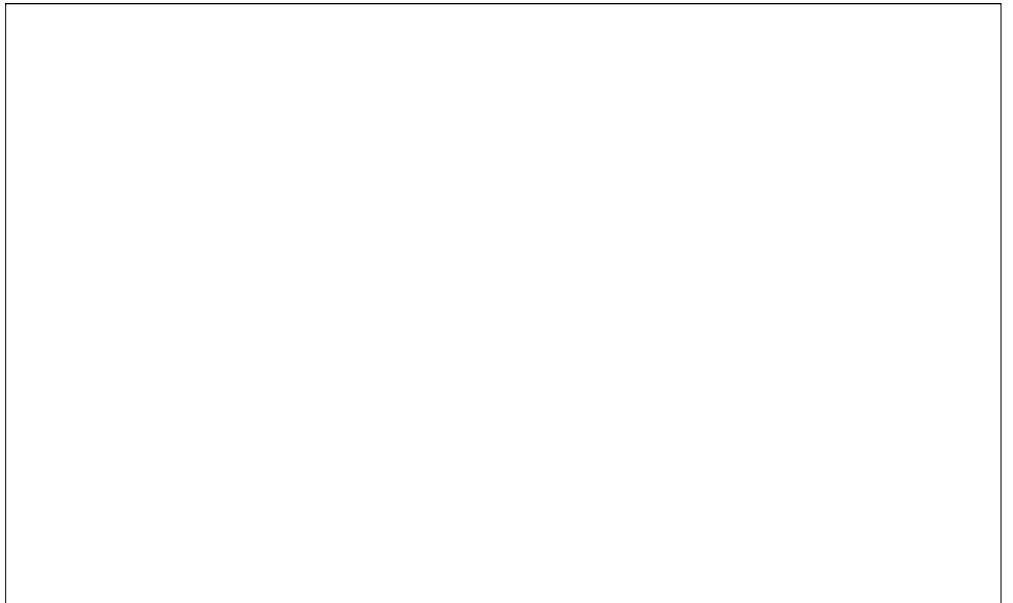
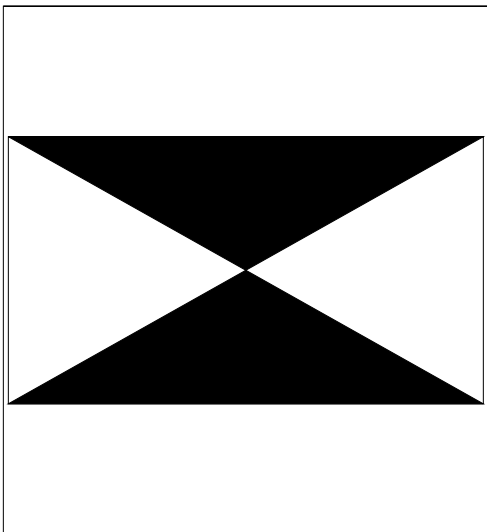

Seq	Scene	Panel
28	1025	1

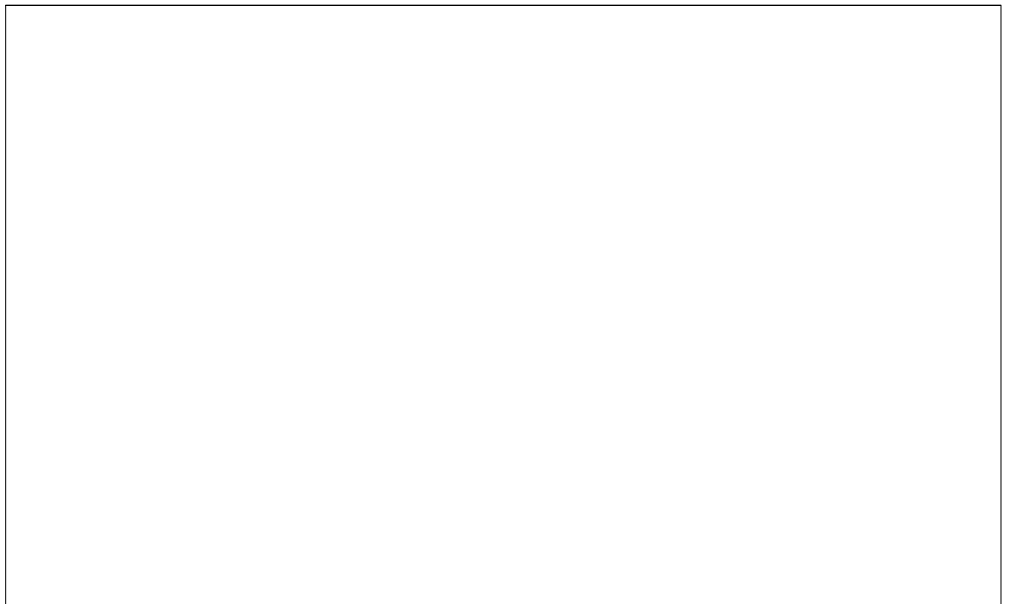

Seq	Scene	Panel
28	1025	2

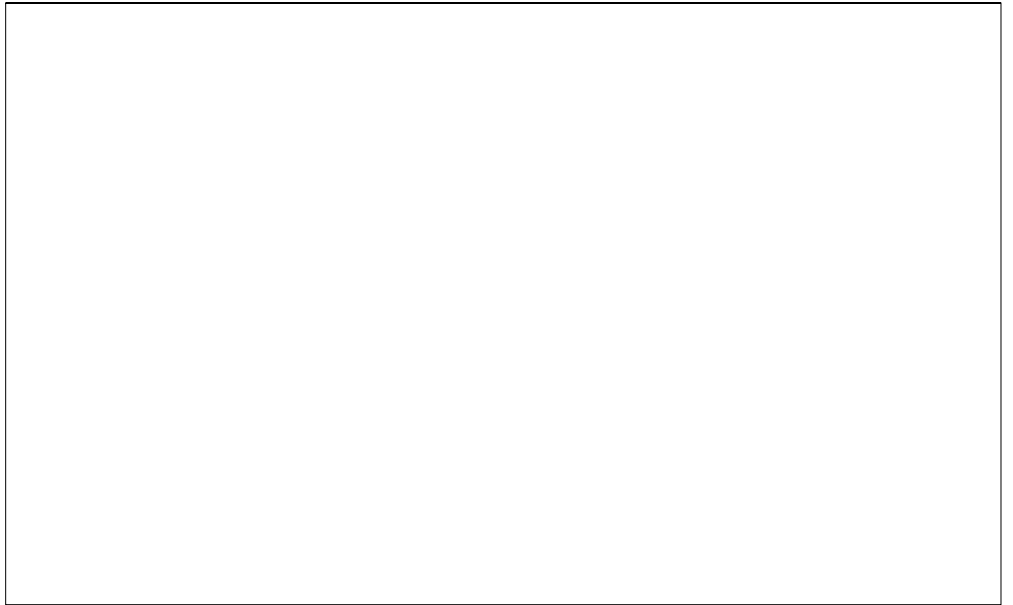
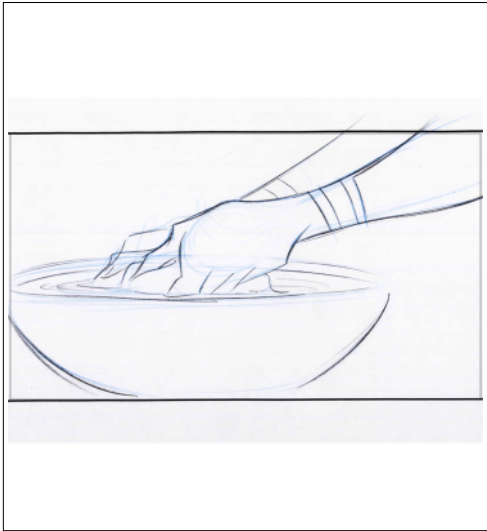

Seq	Scene	Panel
28	1025	3

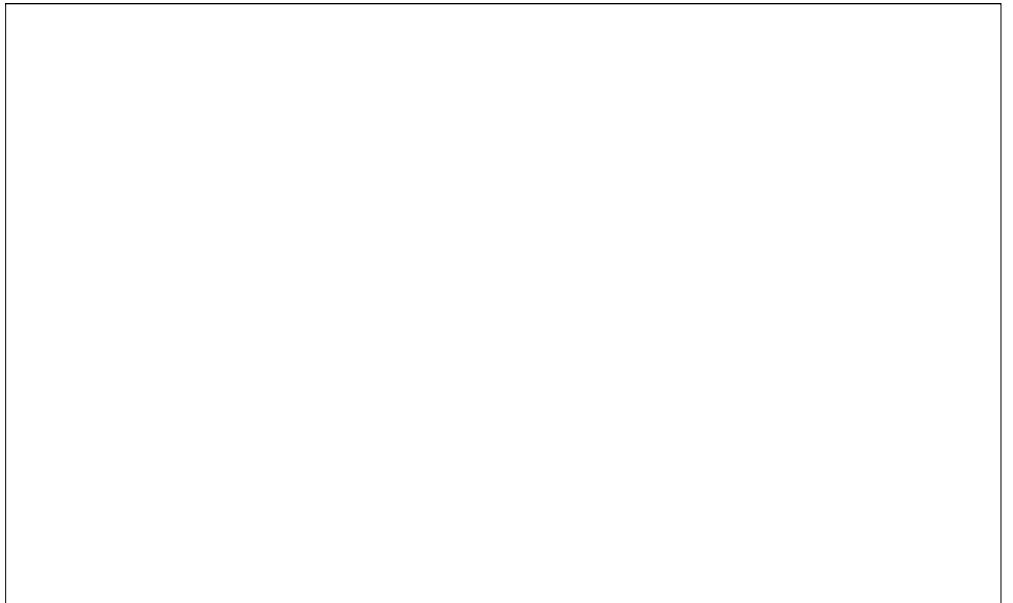
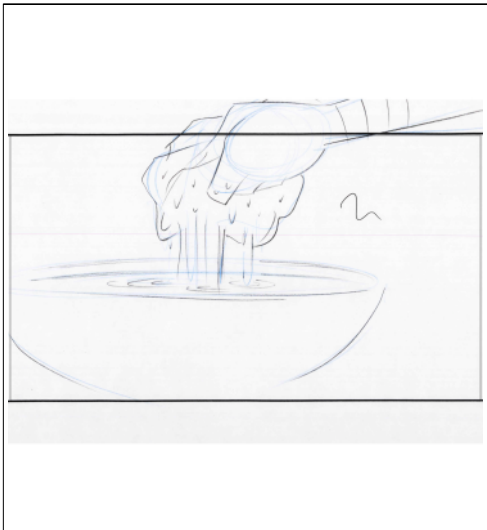

Seq	Scene	Panel
28	1026	1

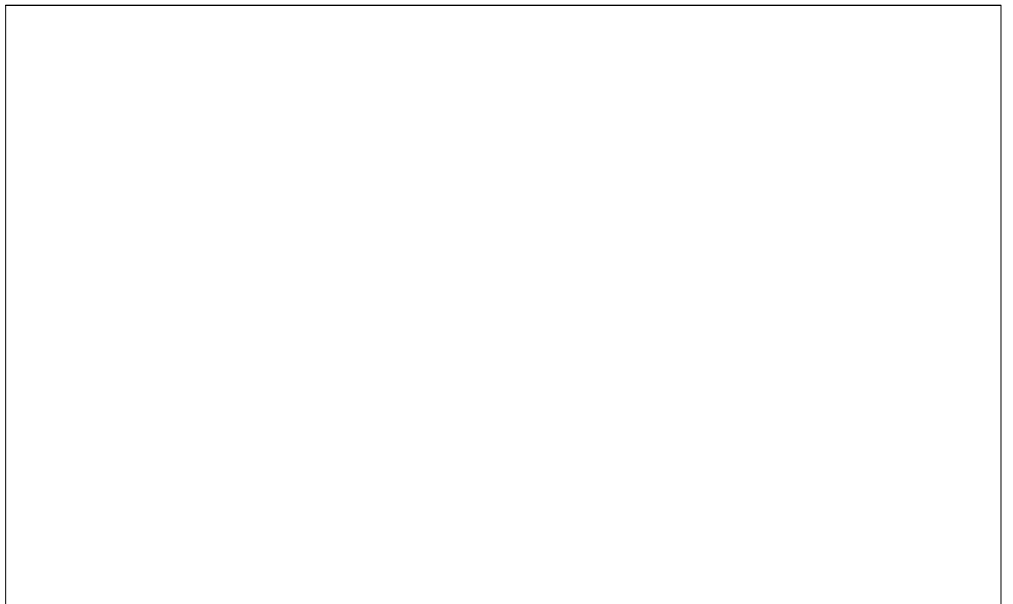
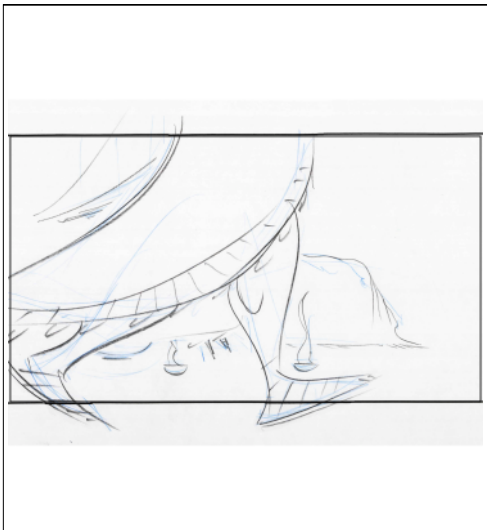

Seq	Scene	Panel
28	1026	2

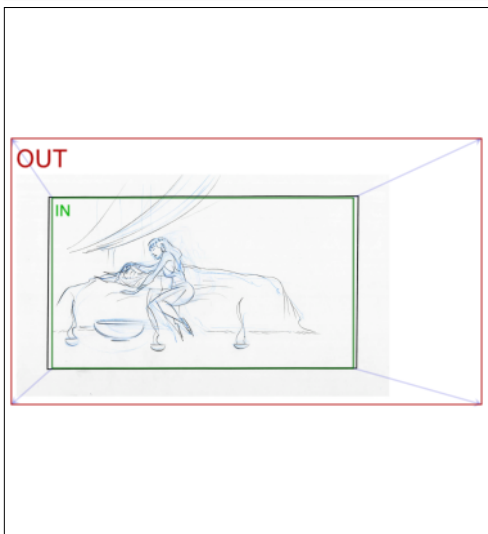

Seq	Scene	Panel
28	1026	3

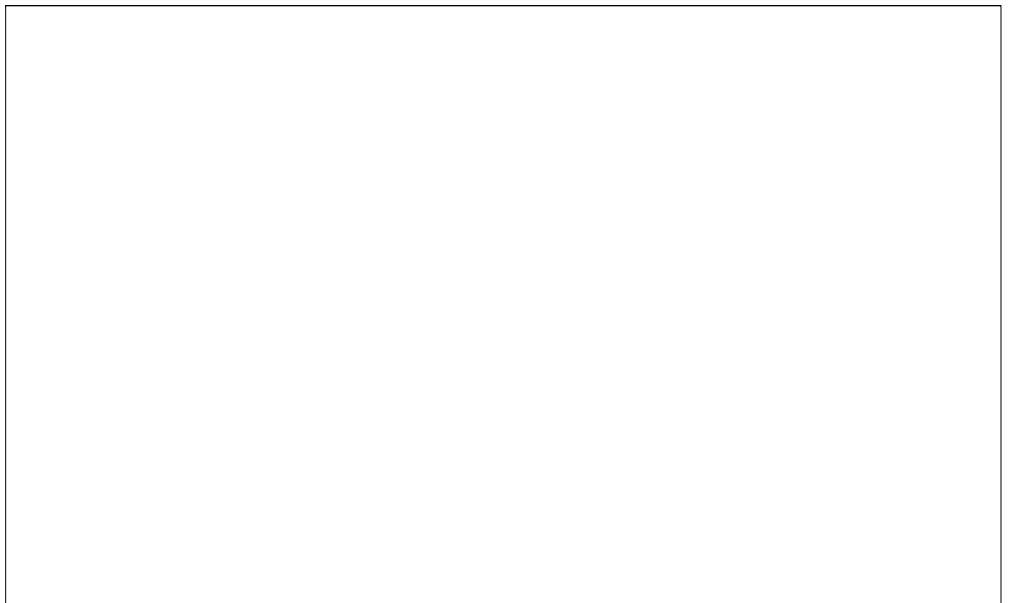
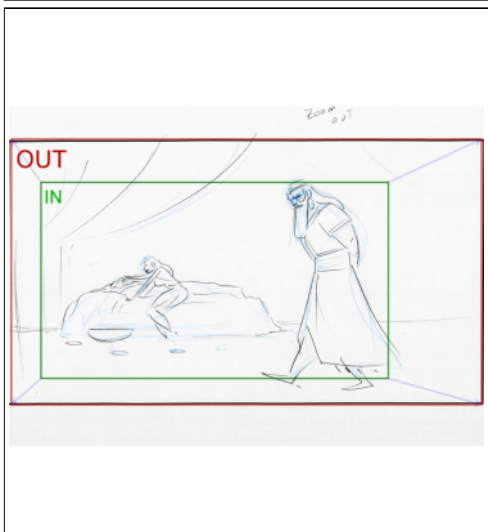

Seq	Scene	Panel
28	1026	4



Dialog
Enkidu: Me presento ante ti, Shamash

Seq	Scene	Panel
28	1027	1



Dialog
 Enkidu:
 "Estoy muriendo..."

Seq	Scene	Panel
28	1027	2



Dialog
 Enkidu:
 Maldigo a aquel cazador que me encontré, el que no me dejó ser una bestia más!

Seq	Scene	Panel
28	1028	1



Dialog
 Enkidu:
 Que la caza escape de sus trampas.

Seq	Scene	Panel
28	1029	1



Dialog

Enkidu:

Y tú, Shamhat, prostituta sagrada, ven acá!

Seq	Scene	Panel
28	1029	2



Dialog

Enkidu:

Decretaré tu destino para toda la eternidad

Seq	Scene	Panel
28	1029	3

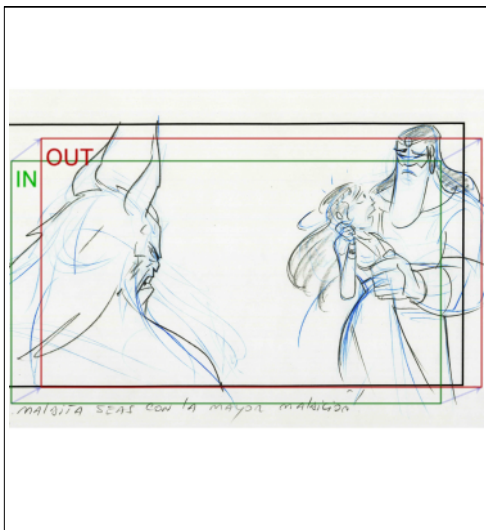

Dialog

Enkidu:

Maldita seas con la mayor maldición!

Seq	Scene	Panel
28	1029	4

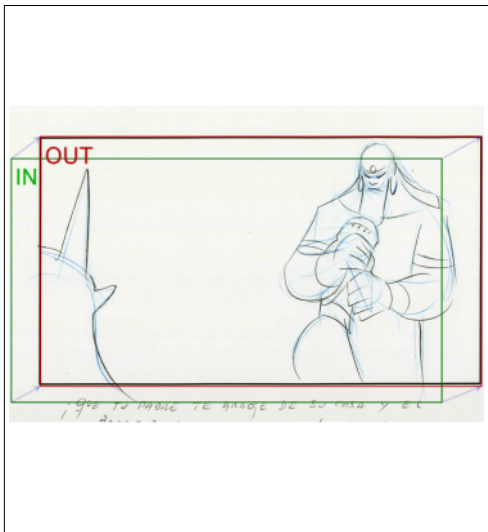

Dialog

Enkidu:

Que el vino ensucie tus hermosos pechos y el vómito del borracho

Seq	Scene	Panel
28	1030	1

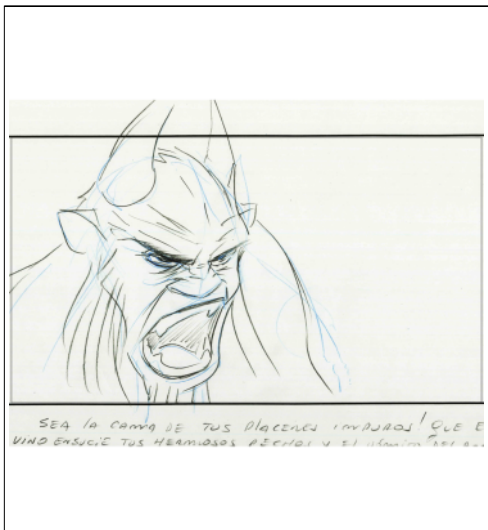

Dialog

Enkidu: manche tu vestido de fiesta

Seq	Scene	Panel
28	1031	1

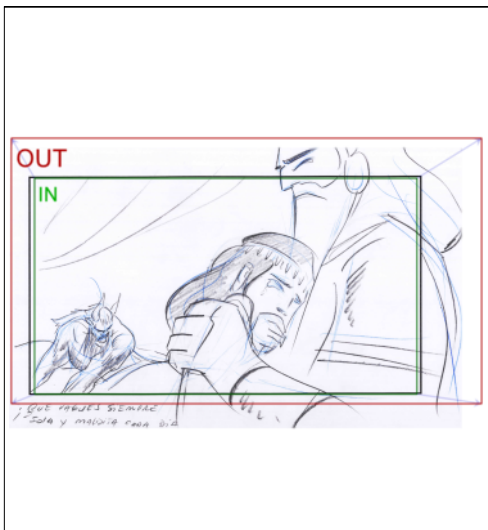

Dialog

Enkidu: Que vagues siempre sola y maldita cada día de tu vida!

Seq	Scene	Panel
28	1032	1

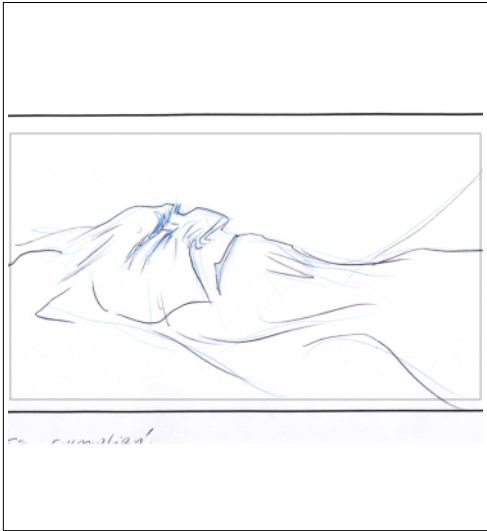

Seq	Scene	Panel
28	1033	1

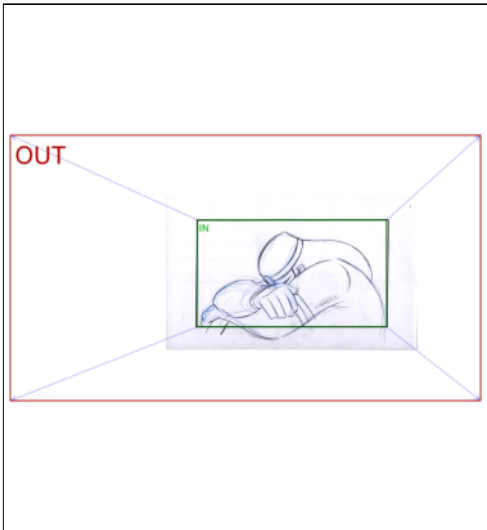

Seq	Scene	Panel
28	1033	2

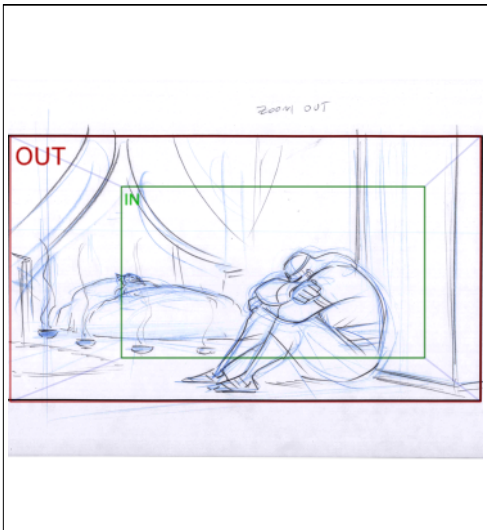

Seq	Scene	Panel
28	1033	3



Dialog
 Enkidu: Amigo mío,

Seq	Scene	Panel
28	1034	1

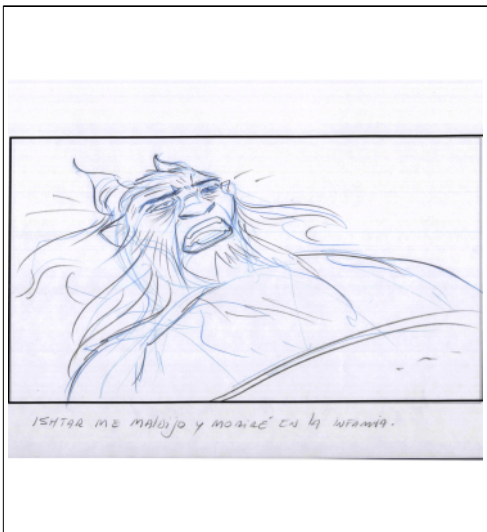

Dialog
 Enkidu:
 el fin se acerca!

Seq	Scene	Panel
28	1035	1

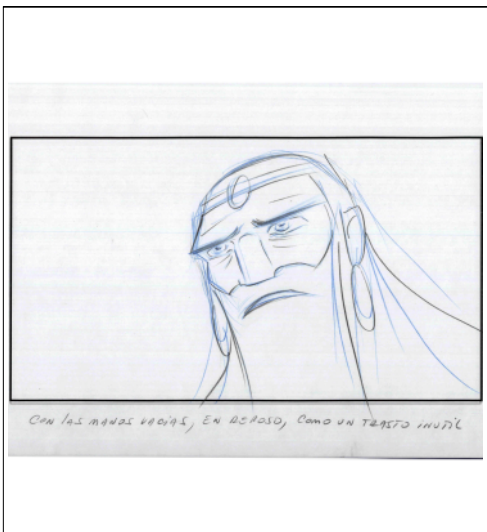

Dialog
 Enkidu en off:
 Ishtar me maldijo y moriré en la infamia.
 con las manos vacías, en reposo, como un trasto inútil

Seq	Scene	Panel
28	1036	1



ISHTA ME MALUJO Y MORIÓ EN LA INFANCIA.

Seq	Scene	Panel
28	1036	2

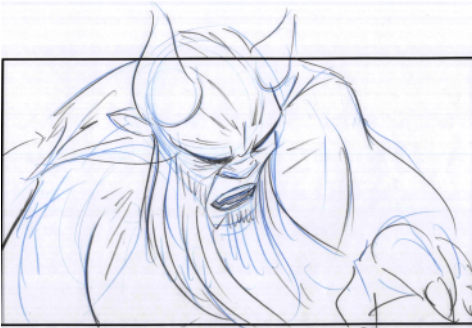

NO COMO UN HÉROE QUE CAE BATALLANDO!

Dialog

Enkidu: No como un héroe que cae batallando!

Seq	Scene	Panel
28	1036	3

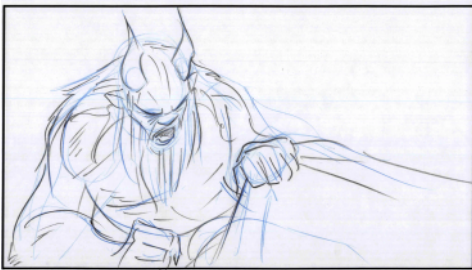

EL QUE MUERE EN COMBATE ES BENDICIDO!

Dialog

Enkidu: El que muere en combate es bendecido,

Seq	Scene	Panel
28	1036	4



Dialog

Enkidu: pues termina sus dias persiguiendo una causa

Seq	Scene	Panel
28	1036	5

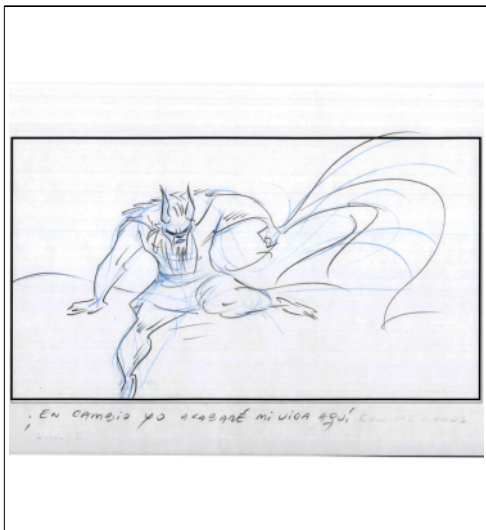

Dialog

Enkidu: En cambio yo acabaré con mi vida aquí

Seq	Scene	Panel
28	1037	1

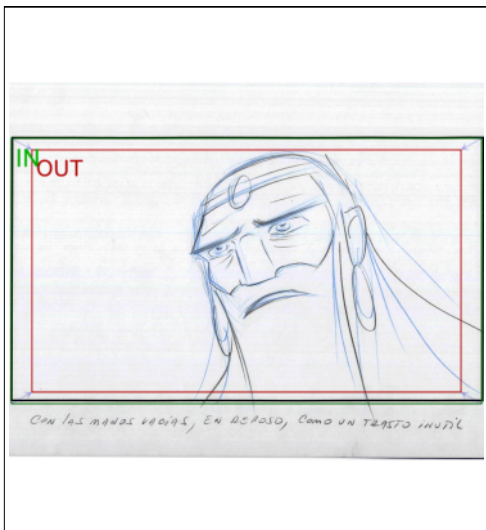

Dialog

ENKIDU EN OFF:

CON LAS MANOS VACÍAS EN REPOSO, COMO UN TRASTO INÚTIL,

Seq	Scene	Panel
28	1038	1

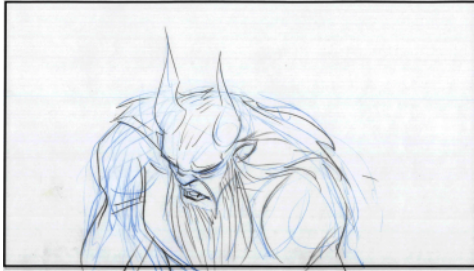

COMO UNA ESPADA SIN AFILAR!
GILGAMESH ME AYUDO EN LA LUCHA EN EL CORAZON DE URUK

Dialog

Enkidu: como una espada sin afilar! Gilgamesh me ayudo en la lucha en el corazón de Uruk

Seq	Scene	Panel
28	1038	2



¿POR PUE AHORA MI AMIGO ME ABANDONA?

Dialog

Enkidu:

Gilgamesh me ayudo en la lucha en el corazón de Uruk y en el Desierto.

Seq	Scene	Panel
28	1039	1

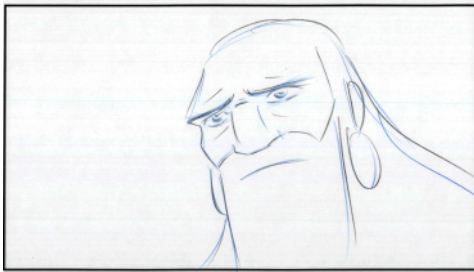

CUANDO YO TENIA MIEDO, EL ME DIO VALOR

Dialog

Enkidu: cuando yo tenía miedo, él me dió valor

Seq	Scene	Panel
28	1040	1

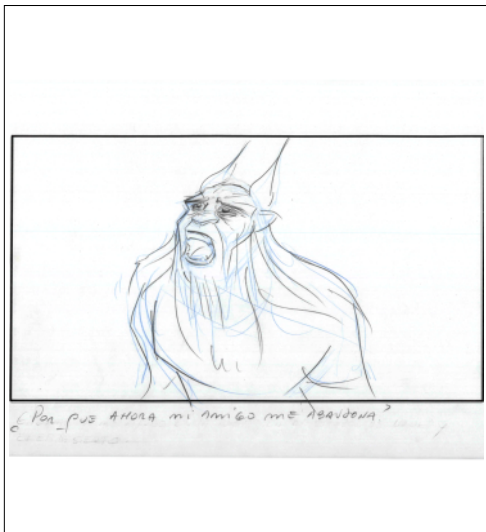

Dialog

Enkidu:

Por qué ahora mi amigo me abandona?

Seq	Scene	Panel
28	1040	2

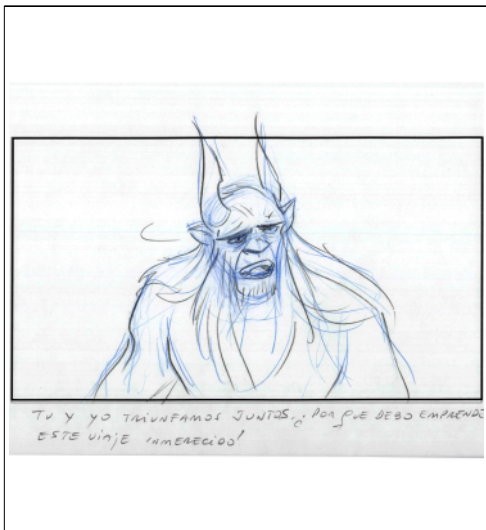

Dialog

Enkidu: Tú y yo triunfamos juntos. Por qué debo emprender este viaje inmerecido?

Seq	Scene	Panel
28	1041	1

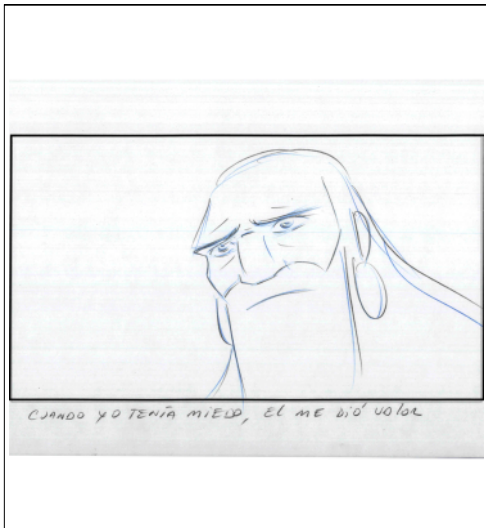

Dialog

Enkidu en off:

Tú y yo triunfamos juntos. Por qué debo emprender este viaje inmerecido?

Seq	Scene	Panel
28	1042	1

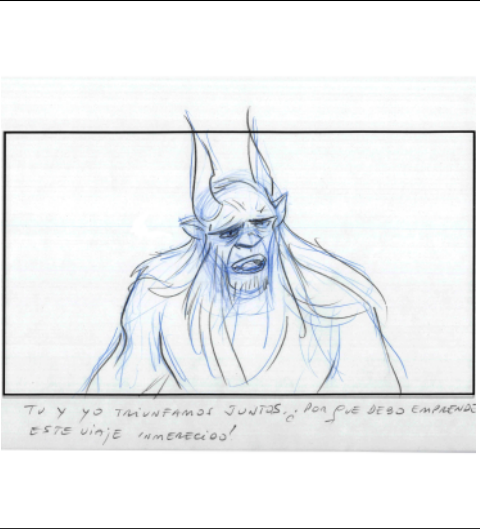

Dialog
 Enkidu:
 Por qué debo emprender solo este viaje inmerecido?

Seq	Scene	Panel
28	1043	1

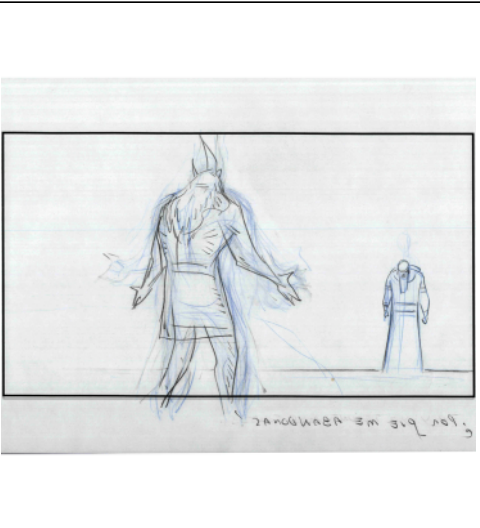

Dialog
 Enkidu:
 Por qué, por qué me abandonas?

Seq	Scene	Panel
28	1044	1

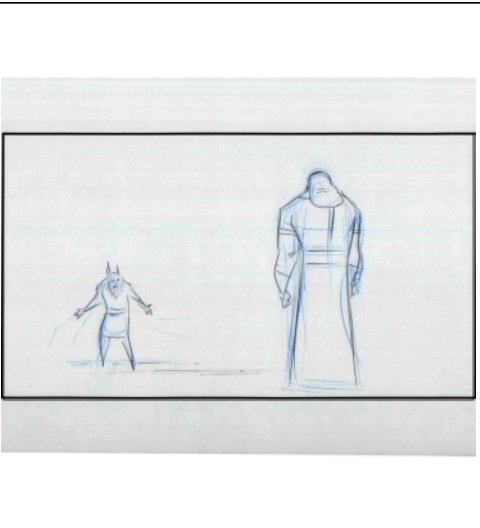

Seq	Scene	Panel
28	1044	2

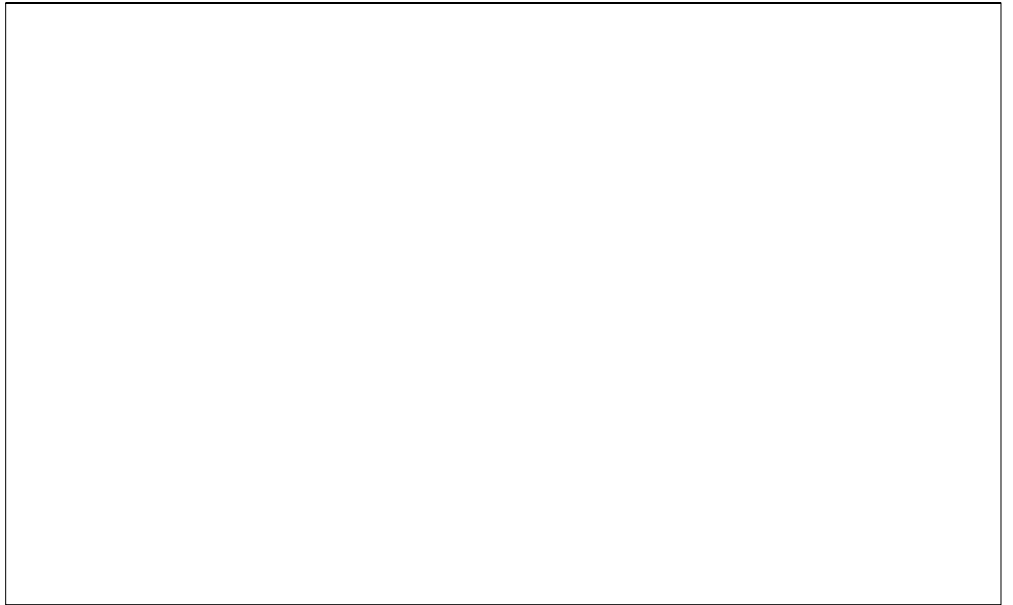
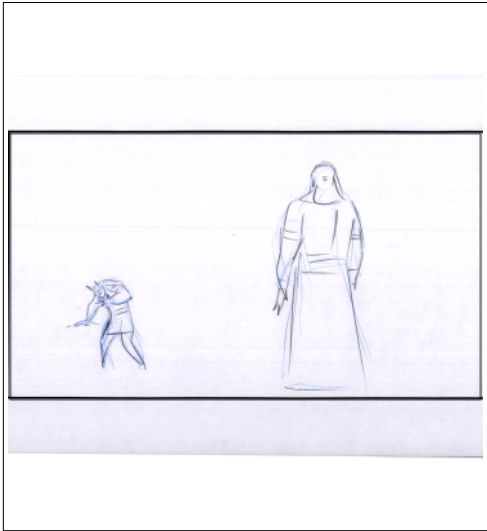

Seq	Scene	Panel
28	1044	3

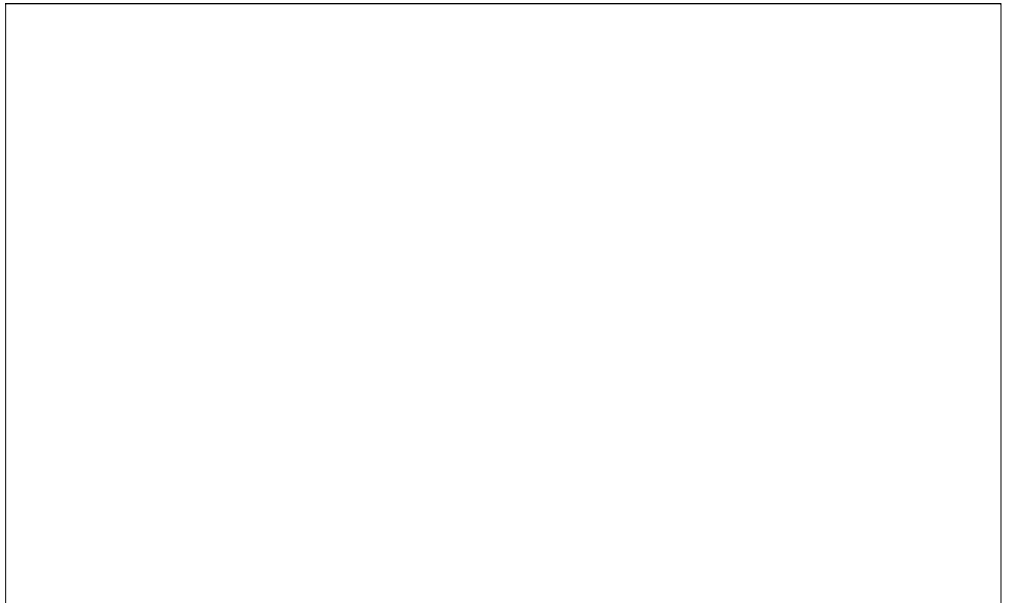
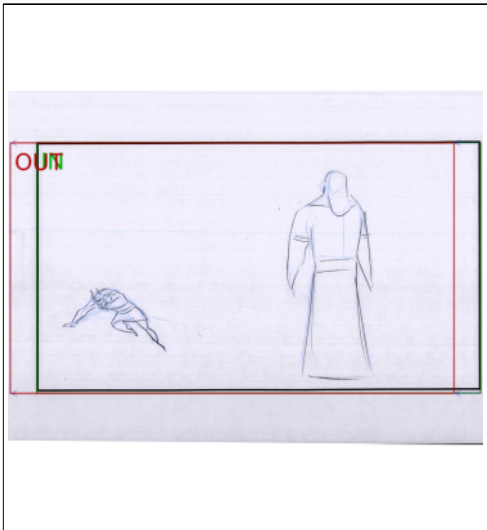

Seq	Scene	Panel
28	1044	4

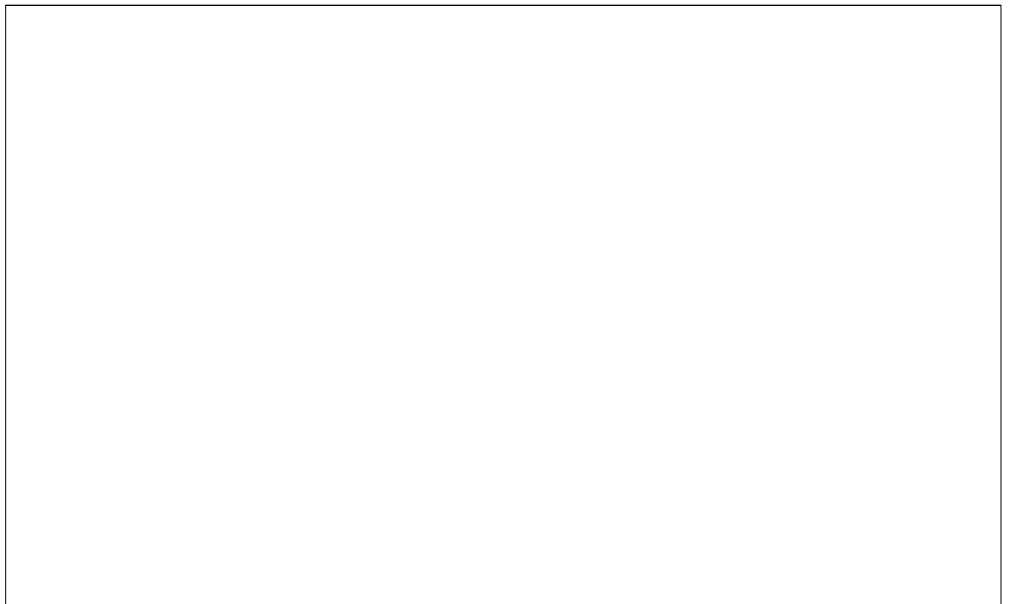
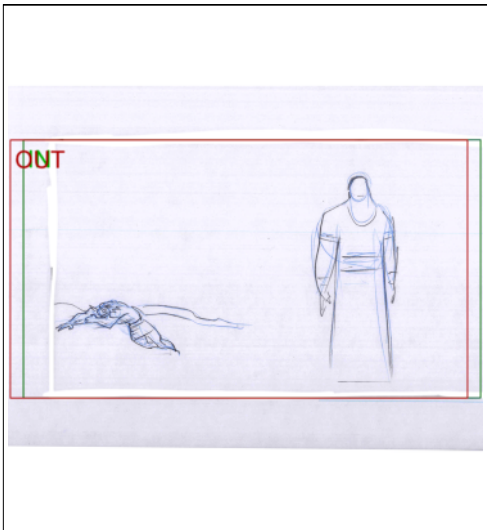

Seq	Scene	Panel
28	1045	1

(Amanecer)

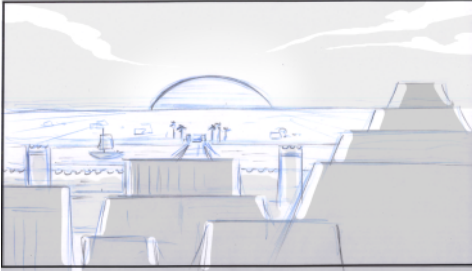

Dissolve



Seq	Scene	Panel
28	1046	1

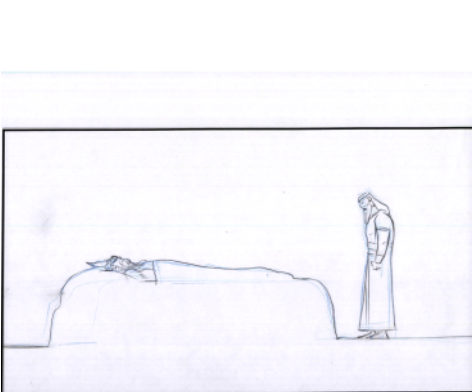

ENTRE LOS QUE FUMOSOS, NOS ABIMOS PASO. QUE SE
LAMENTE LA ESTERA COMO SI FUERA EL MADRE

Seq	Scene	Panel
28	1046	2

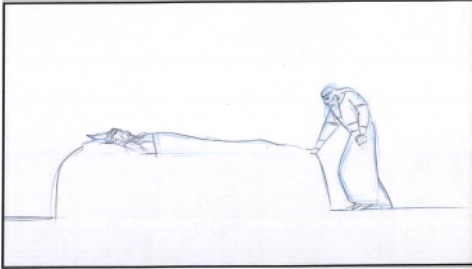

Y QUE TE HAYEN EL OSO, LA HENA, LA PANICAA,

Seq	Scene	Panel
28	1046	3

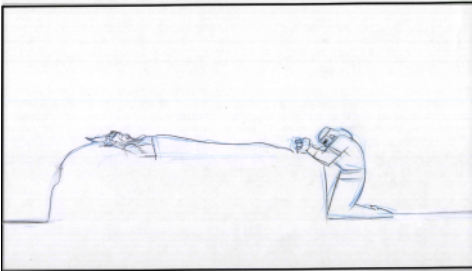

EL TIGRE, EL CABRO Y EL LEONARDO; EL LEON EL
BIFALO, EL VENADO Y LA MANANA SALUJE DEL DESIERTO!

Dissolve

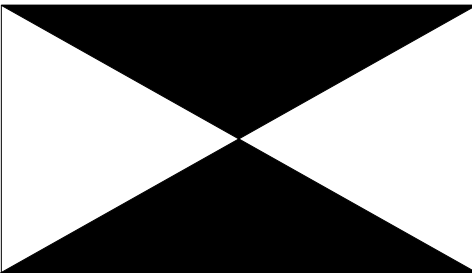

Seq	Scene	Panel
28	1047	1



Dissolve

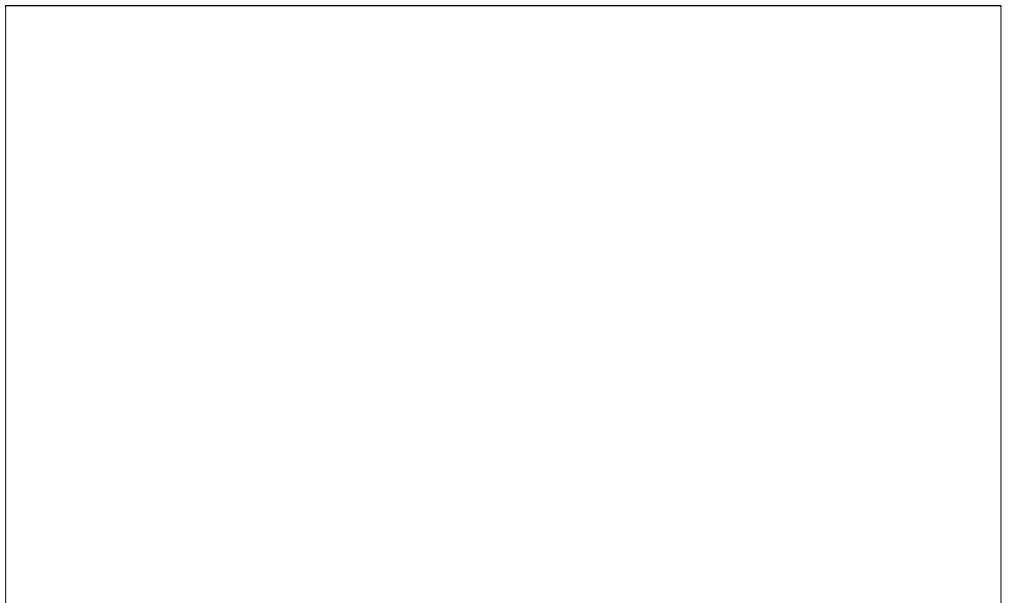
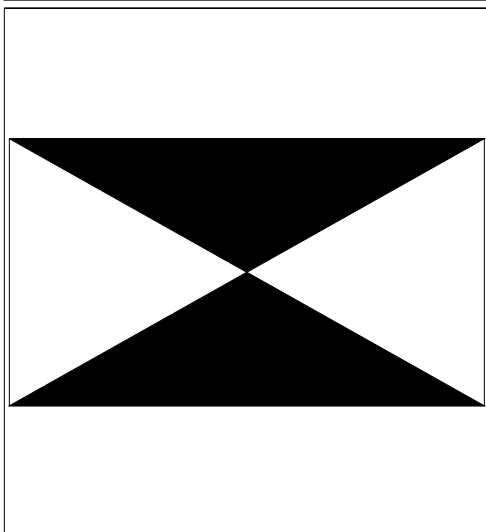

Seq	Scene	Panel
28	1048	1



Dialog
 VOZ EN OFF:
 GILGAMESH LLORÓ JUNTO AL CUERPO DE SU AMIGO DURANTE SIETE DÍAS. HASTA QUE,
 LA SEPTIMA NOCHE, TUVO QUE ACEPTAR QUE ESTABA MUERTO.

Seq	Scene	Panel
28	1048	2

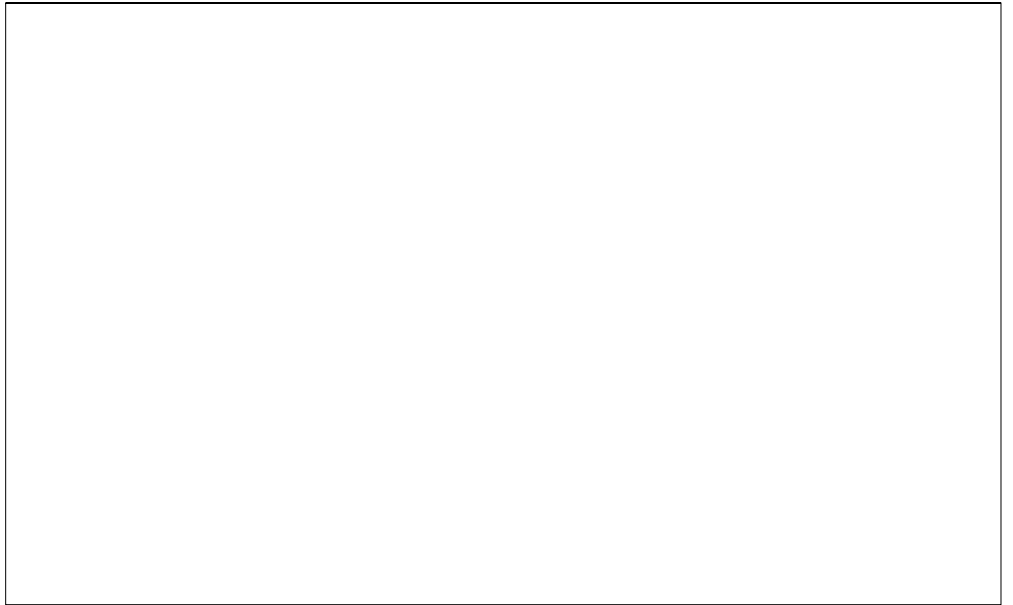
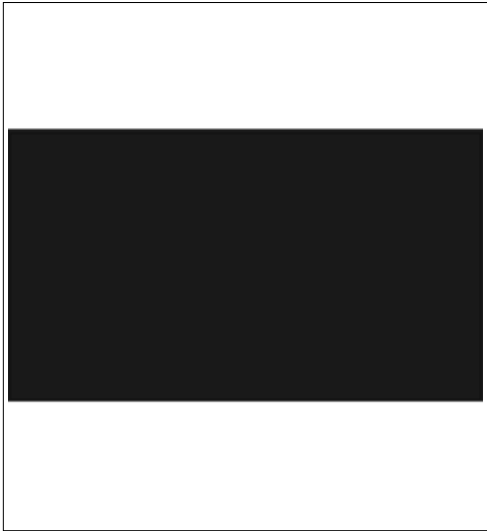

Seq	Scene	Panel
28	1049	1

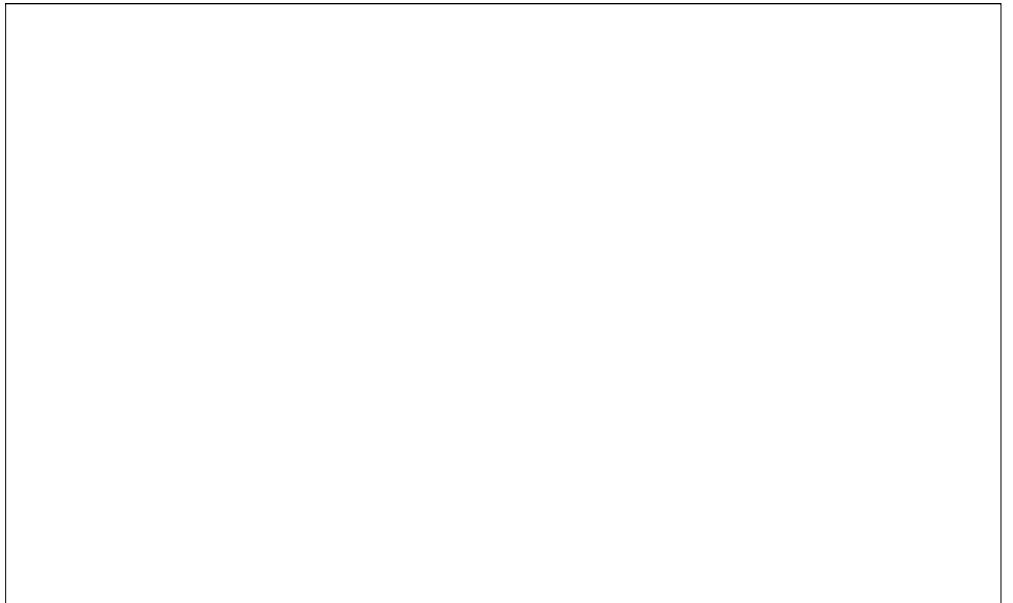
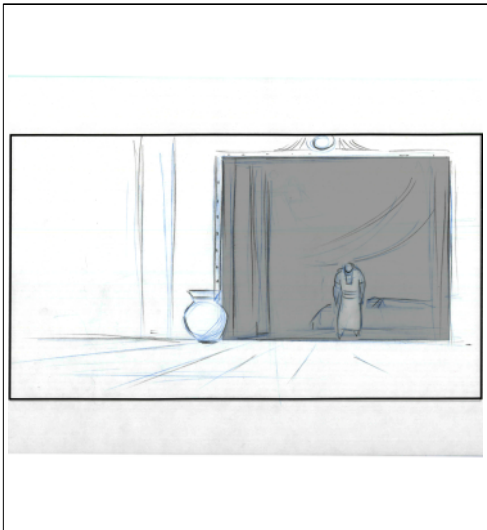

Seq	Scene	Panel
28	1049	2

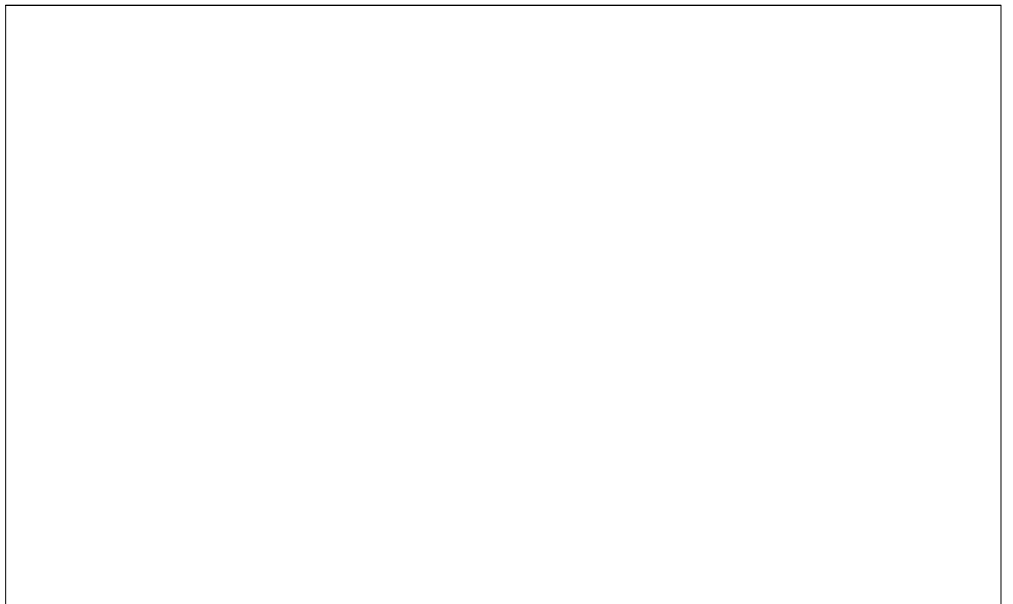
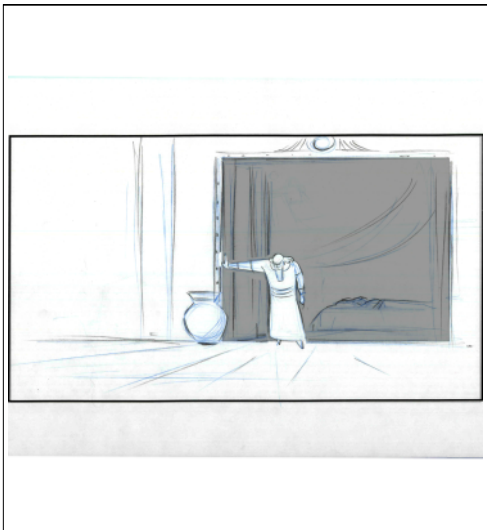

Seq	Scene	Panel
28	1050	1

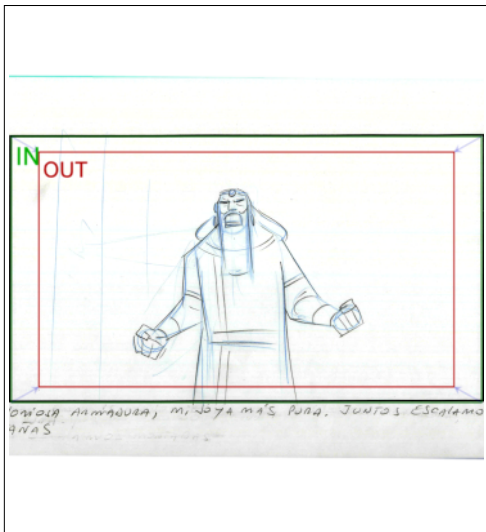

Dialog

GILGAMESH:

ESCUCHEN, HABITANTES DE URUK! Y QUE TAMBIÉN ME OIGA EL MUNDO!

Seq	Scene	Panel
28	1051	1

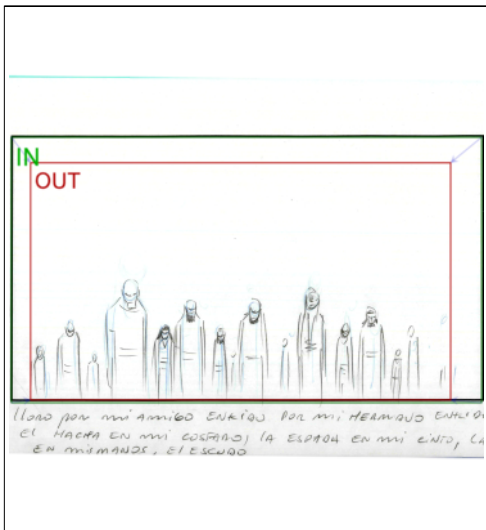

Dialog

GILGAMESH EN OFF:

LLORO POR MI AMIGO ENKIDU. POR MI HERMANO ENKIDU.

Seq	Scene	Panel
28	1052	1

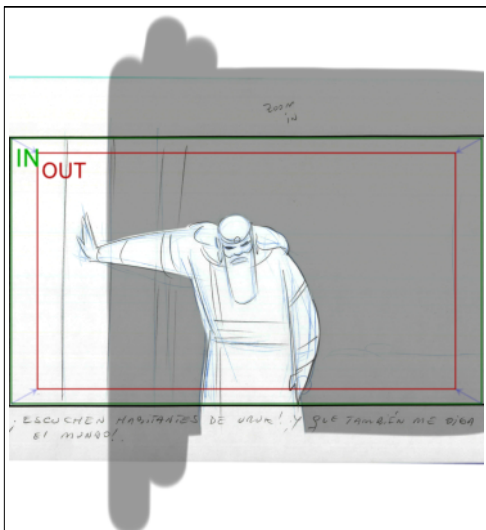

Dialog

GILGAMESH:

EL ACHA A MI COSTADO, LA ESPADA EN MI CINTO, LA FUERZA EN MIS MANOS. EL ESCUDO,

Seq	Scene	Panel
28	1053	1



Dialog

GILGAMESH EN OFF:

LA GLORIOSA ARMADURA, MI JOYA MAS PURA.

Seq	Scene	Panel
28	1054	1

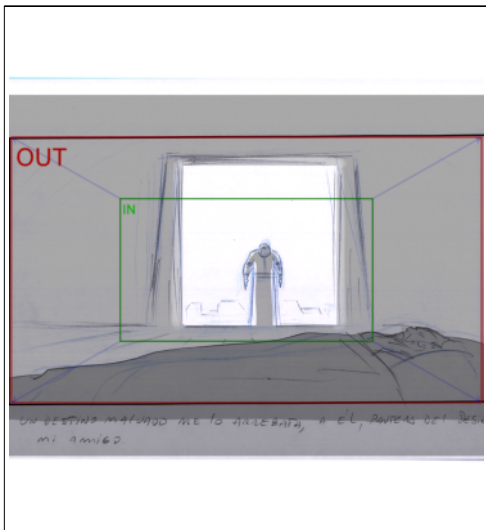

Dialog

GILGAMESH:

UN DESTINO MALVADO ME LO ARREBATA.
A ÉL, PANTERA DEL DESIERTO... MI AMIGO.

Seq	Scene	Panel
28	1055	1

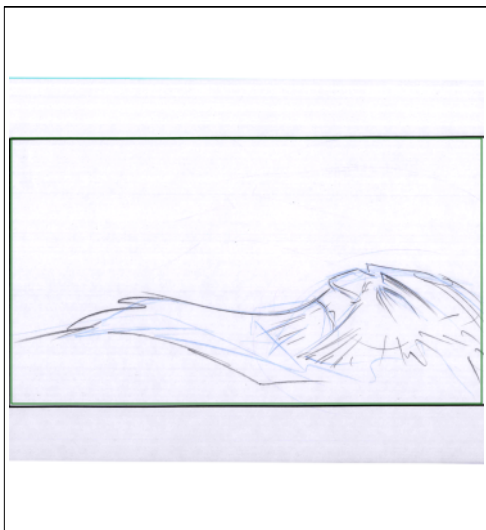

Seq	Scene	Panel
28	1055	2

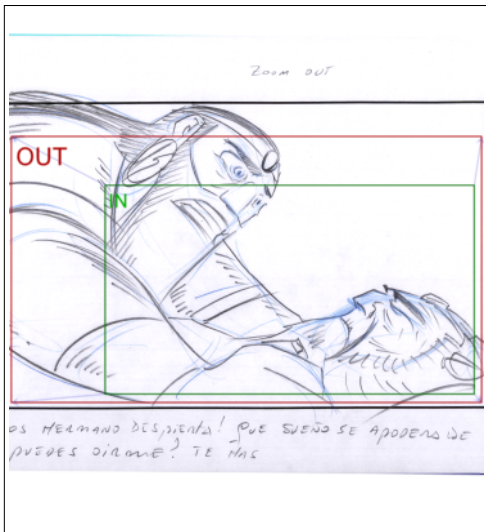

Dialog
 GILGAMESH:
 VAMOS HERMANO, DESPIERTA! QUE SUEÑO SE APODERA DE TI? YA NO PUEDES OIRME?

Seq	Scene	Panel
28	1055	3

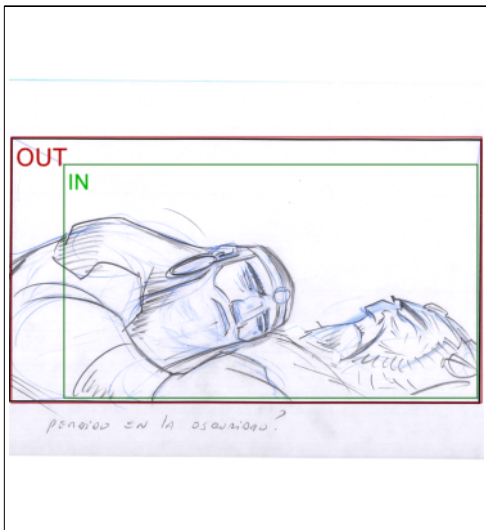

Dialog
 GILGAMESH:
 TE HAS PERDIDO EN LA OSCURIDAD?

Seq	Scene	Panel
28	1055	4

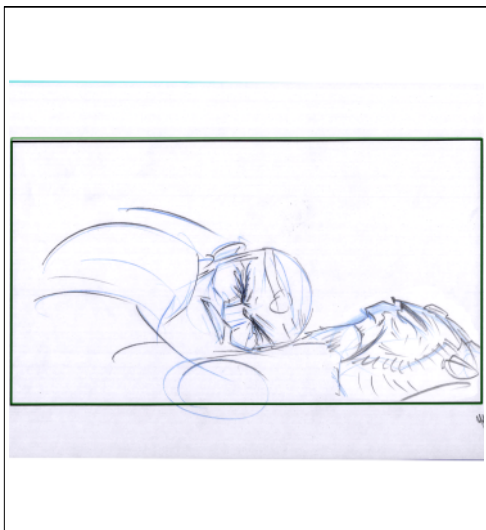

Dialog



Seq	Scene	Panel
28	1055	5

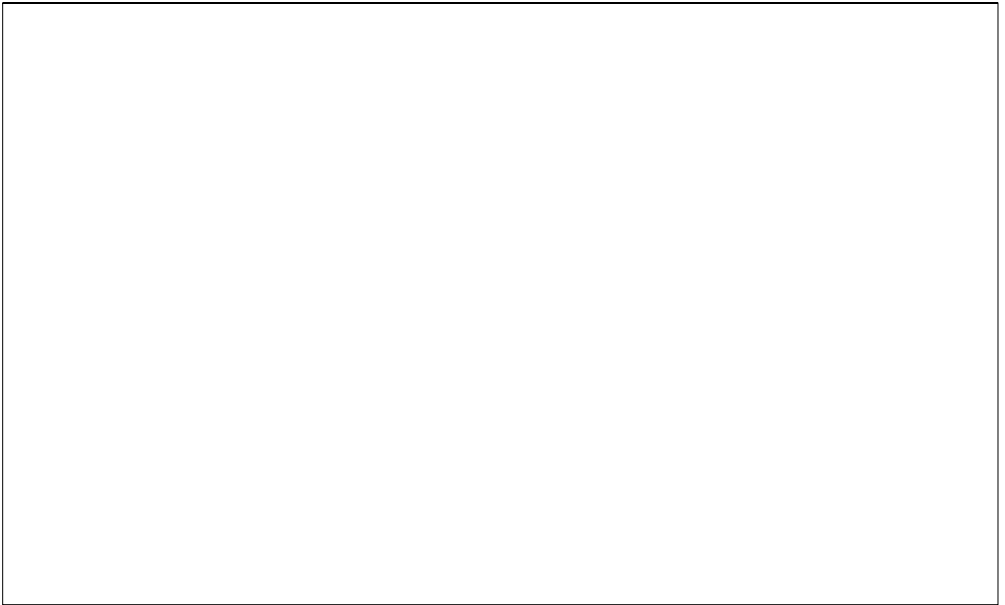
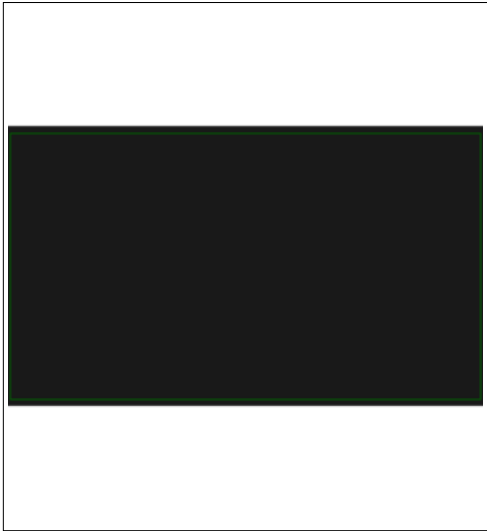

Dissolve

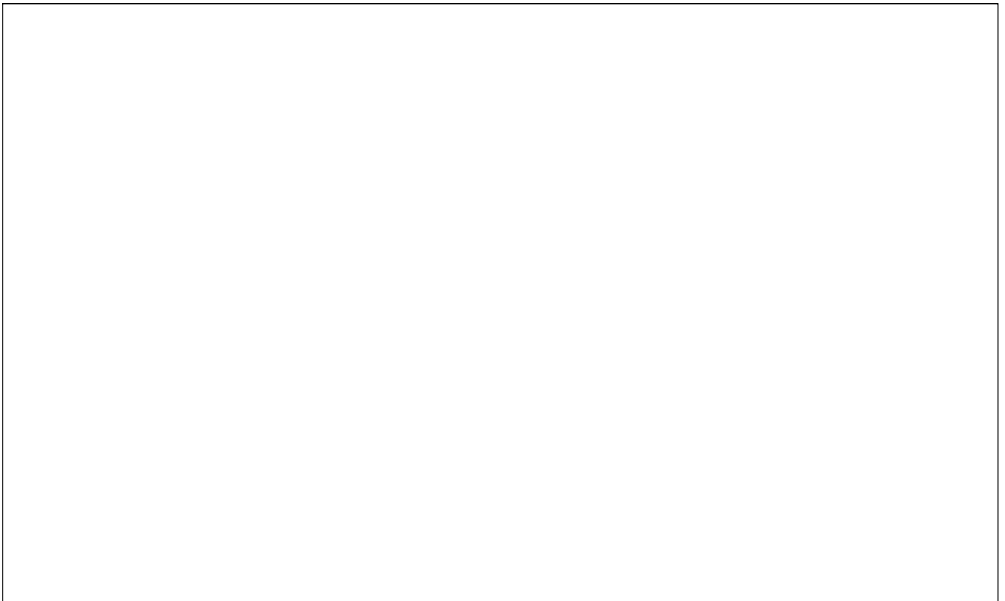
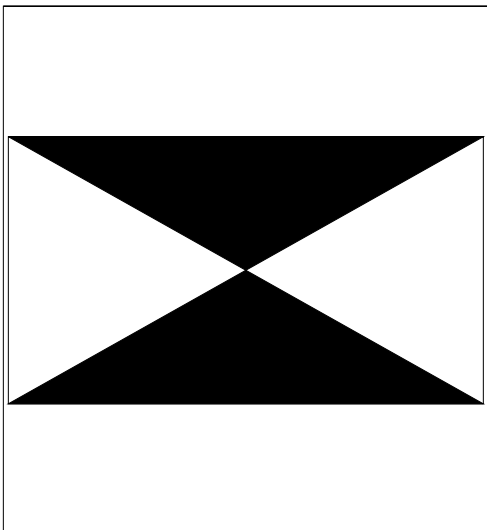

Seq	Scene	Panel
29	1056	1

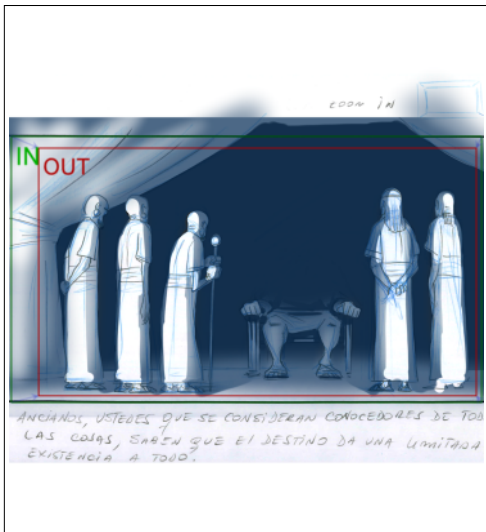

Dialog

GILGAMESH:

ANCIANOS, USTEDES QUE SE CONSIDERAN CONOCEDORES DE TODAS LAS COSAS, SABEN QUE EL DESTINO DA UNA LIMITADA EXISTENCIA A TODO.

Seq	Scene	Panel
29	1057	1



Dialog

GILGAMESH EN OFF:

TARDE O TEMPRANO LA GENTE MORIRÁ Y LA MURALLA QUE NOS RODEA CAERÁ.

Seq	Scene	Panel
29	1058	1

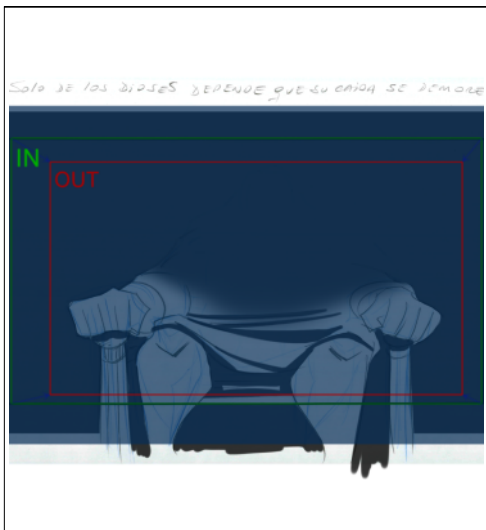

Dialog

GILGAMESH:

SOLO DE LOS DIOS DEPENDE QUE SU CAIDA SE DEMORE.

DESPUÉS DE TANTO BATALLAR, DESPUÉS DE HABER LOGRADO LO QUE NADIE HASTA AHORA, YO TAMBIÉN VOY A MORIR? TODO TERMINARÁ CUANDO MI CUERPO DESCANSE EN EL CORAZÓN DE LA TIERRA.

Seq	Scene	Panel
29	1059	1



Dialog

ANCIANO:

PARA LOS HOMBRES LA MUERTE ES INEVITABLE.

Seq	Scene	Panel
29	1060	1

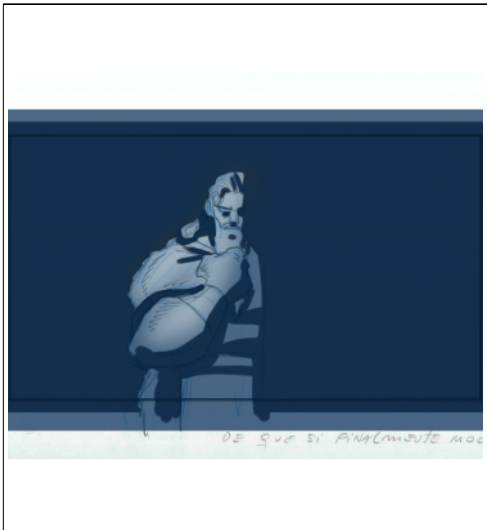

Dialog

GILGAMESH:

NO PARA TODOS.

Seq	Scene	Panel
29	1060	2

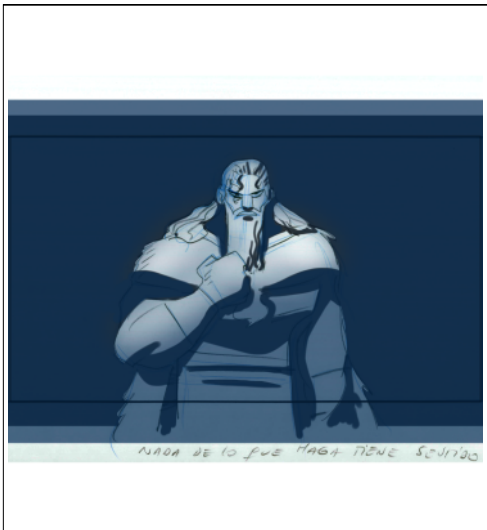

Dialog

GILGAMESH:

RECUERDEN A UTNAPISHTIM.

Seq	Scene	Panel
29	1061	1

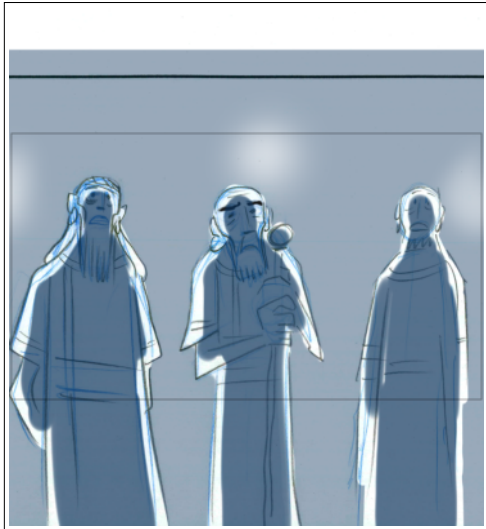

Dialog

GILGAMESH EN OFF:

EL ES UN HOMBRE Y SIN EMBARGO LOS DIOS LE DIERON VIDA ETERNA.

Seq	Scene	Panel
29	1062	1

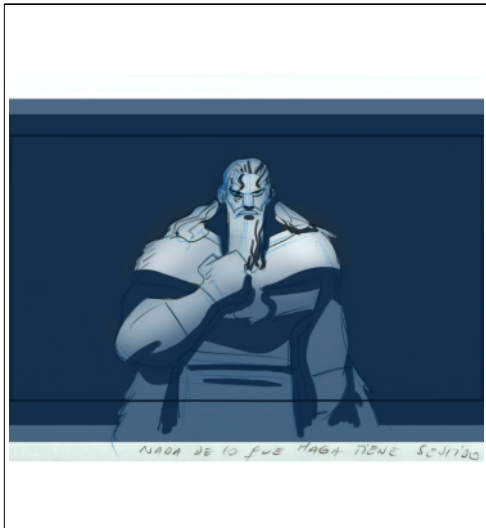

Dialog

GILGAMESH:

POR ESO ABANDONO URUK. VOY A SU CASA,

Seq	Scene	Panel
29	1063	1

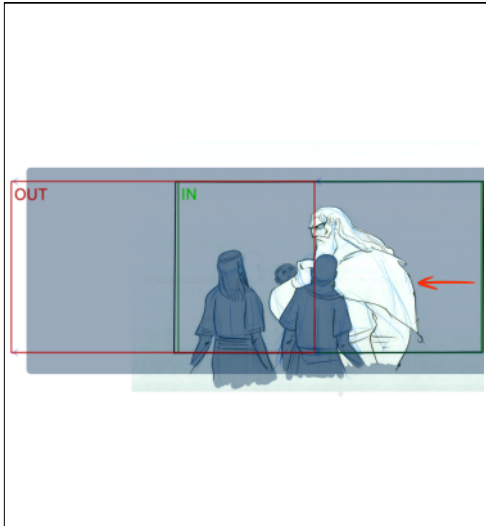

Dialog

GILGAMESH

PARA QUE ME REVELE , SU SECRETO.

Seq	Scene	Panel
29	1063	2

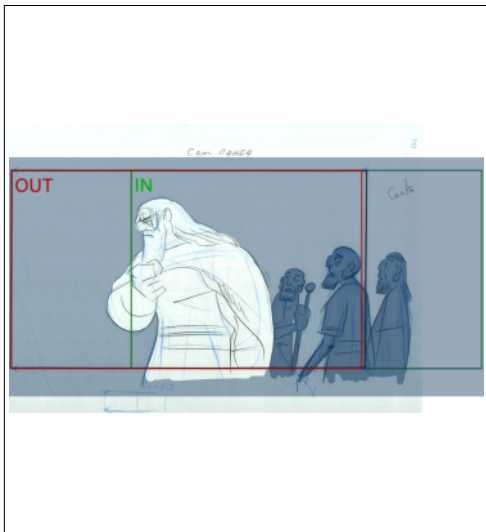

Dialog

ANCIANO:

Y CUÁL SERÁ LA SUERTE DE TU PUEBLO?

Seq	Scene	Panel
29	1064	1



Dialog

GILGAMESH:

DEJO EL GOBIERNO EN SUS MANOS.

Seq	Scene	Panel
29	1065	1

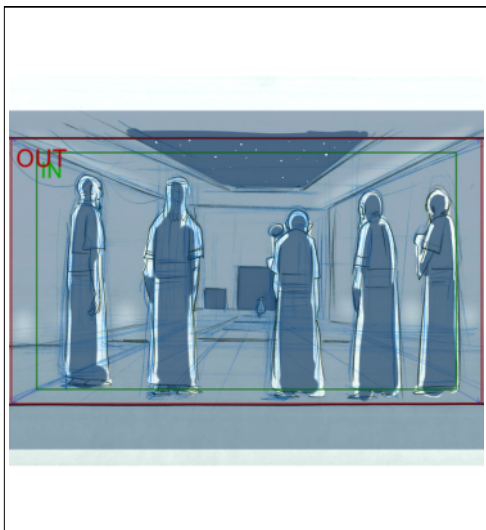

Seq	Scene	Panel
29	1066	1

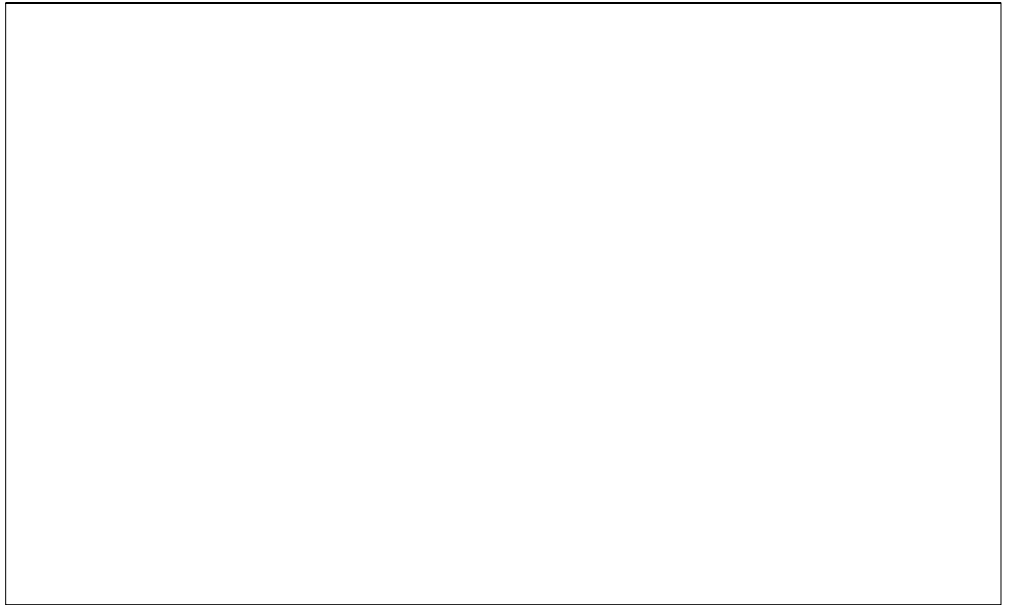
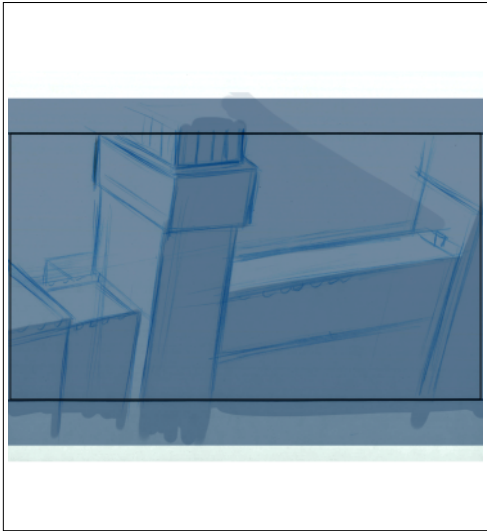

Seq	Scene	Panel
29	1066	2

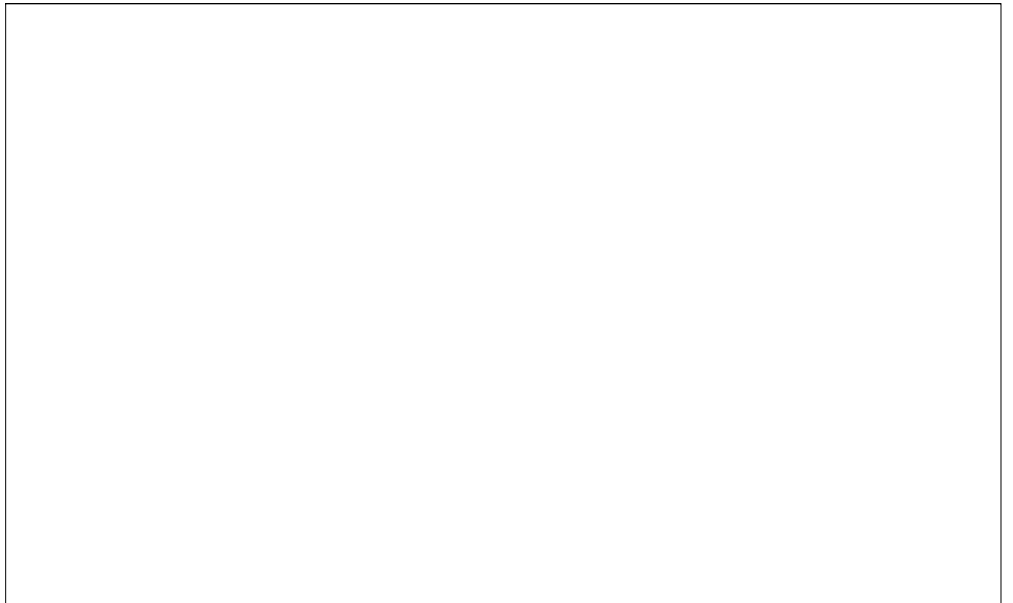
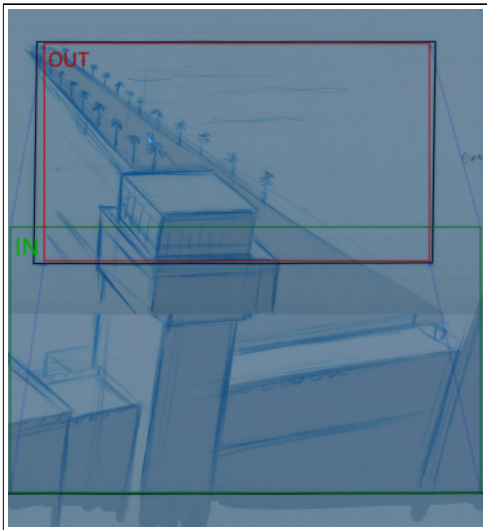

Seq	Scene	Panel
29	1067	1

